



**Fiji** Roads Authority

# STANDARD DRAWINGS

**February 2020**

# CONTENTS

<u>SERIES</u>	<u>DESCRIPTION</u>
100	Road Intersections & Cul de Sac
300	Pavement Construction & Typical Cross Sections
501	Underground Storm Water Drainage
502	Sub Surface Drainage
503	Stormwater Pits & Manholes
504	' V ' Drains Details
601	Incidental Construction Details
602	Pavement Trench Reinstatement Details
603 & 604	Kerbs
700	Road Furniture & Pavement Markings
800	Utility Services Layout

Update	Actioned	Comments
June 2019	A. Ketenilagi	Addition of Series 800 – Utility Services Layout
June 2019	A. Ketenilagi	Addition of Design Specification R 100 – 8 Standard for Cul-De-Sac: 8m & 15m
October 2019	A. Ketenilagi	<ul style="list-style-type: none"> <li>Addition of Design Specification R 604 - 7 and R604 – 8 for Typical Cast in-situ Kerb &amp; Channel details.</li> <li>Addition of Design Specification R 705 – 6 Raised Pedestrian Crossing.</li> </ul>

# INDEX SHEET

## SERIES 100 ROAD INTERSECTIONS AND CUL-DE-SAC

DRAWING NUMBER	DRAWING TITLE
R 100-1	CUL-DE-SAC TURNING HEAD FOR 12m ROAD
R 100-2	CUL-DE-SAC TURNING HEAD FOR 9m ROAD
R 100-3	CUL-DE-SAC TURNING HEAD FOR 9m ROAD
R 100-4	CUL-DE-SAC TURNING HEAD FOR 6m ROAD
R 100-5	INTERSECTION OF 6m, 9m AND 12 m
R 100-6	INTERSECTION OF 12m AND 16 m
R 100-7	CUL-DE-SAC TURNING HEAD FOR 8.8m SERVICE TRUCK
R 100-8	GENERAL DESIGN – STANDARD FOR CUL-DE-SAC – 8m & 15m

---

150  
100  
50  
40  
30  
20  
10

A3 ORIGINAL SIZE

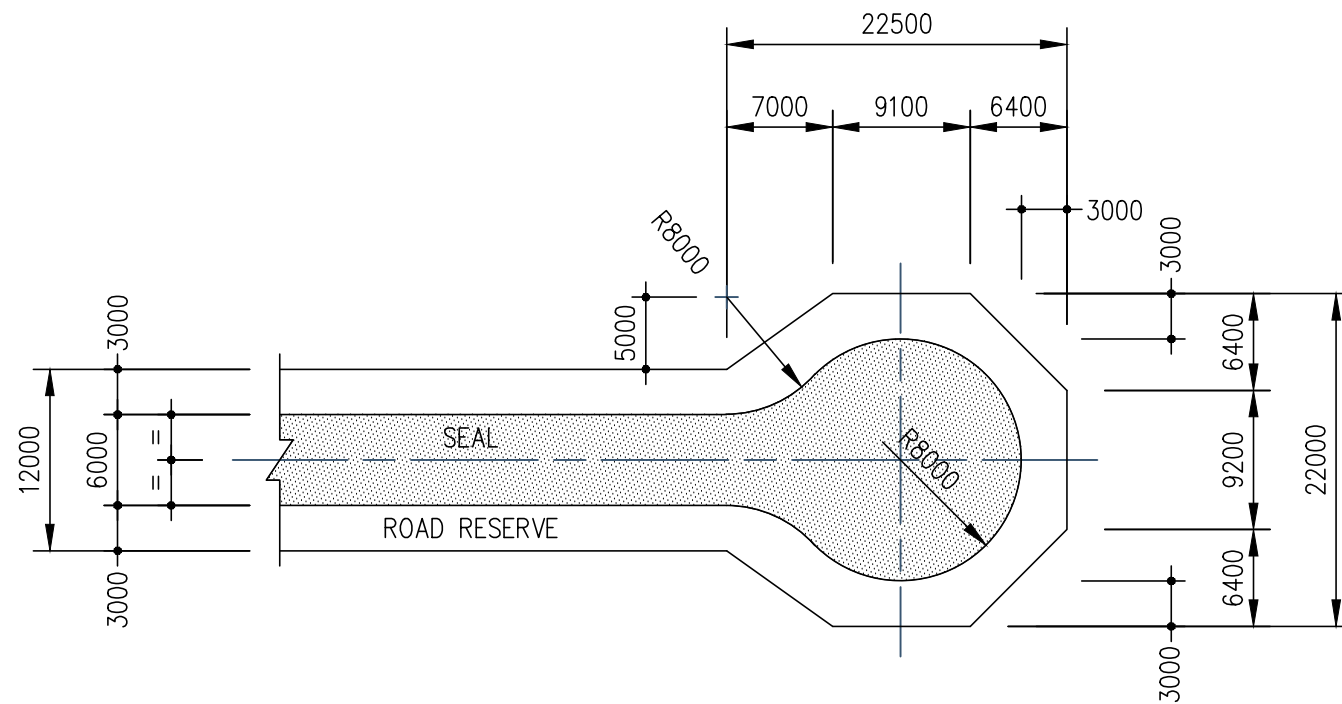
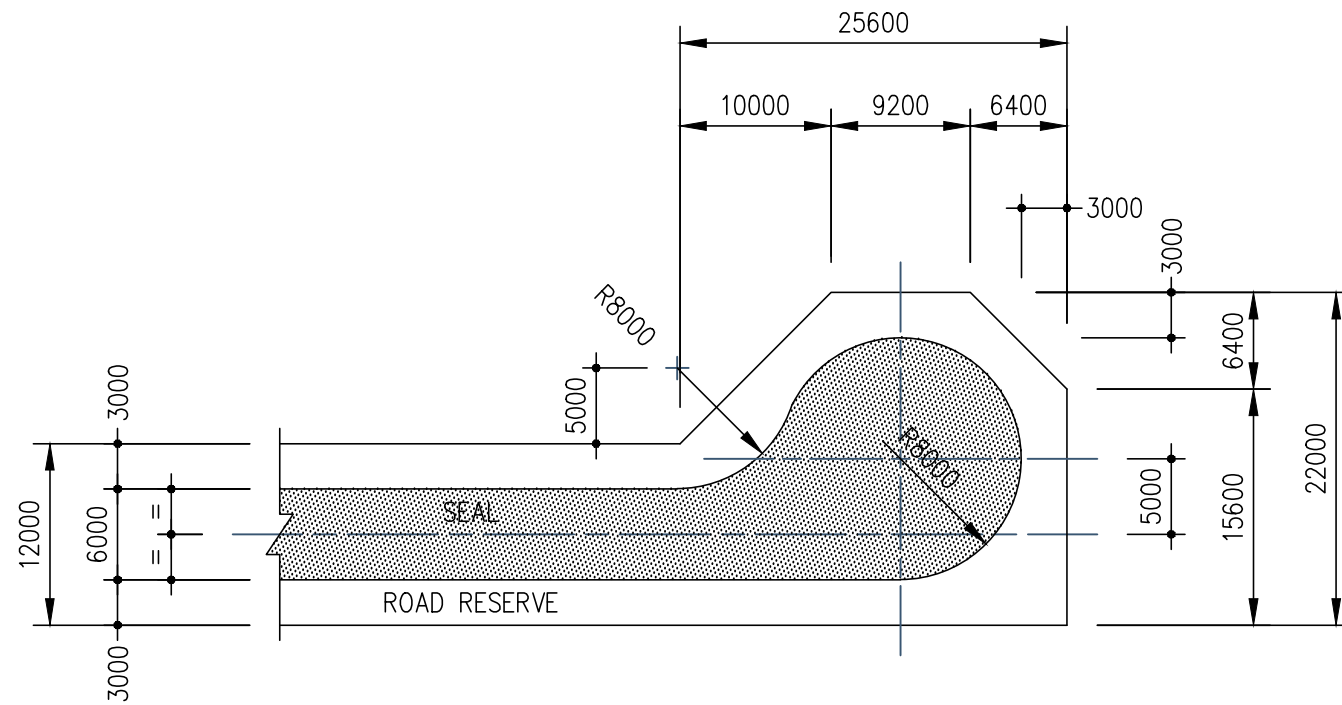

ISSUE	APP'D	DATE	AMENDMENT	BY
E				
D				
C				
B				
A				

**GENERAL NOTES**

1. All dimensions are in mm
2. All dimensions to lip of Kerb and Channel
3. Current FRA practice is to provide a 9.5m radius for residential roads and 15m radius for commercial and industrial roads, Refer R100 drawings for design details

**STANDARD DRAWINGS**

**CUL-DE-SAC TURNING HEADS FOR RESIDENTIAL 12.0M WIDE ROADS**

SCALE SCALE 1:100

DATE 02 MAY 17

DESIGN BY



**Fiji Roads Authority**

DRAWN BY CWS	APPROVED A KETENILAGI	DRAWING No. R 100 - 1	SHEET No. 01	ISSUE
-----------------	--------------------------	--------------------------	-----------------	-------

PLOT DATE 18/10/2018

150

100

50

40

30

20

10

A3 ORIGINAL SIZE

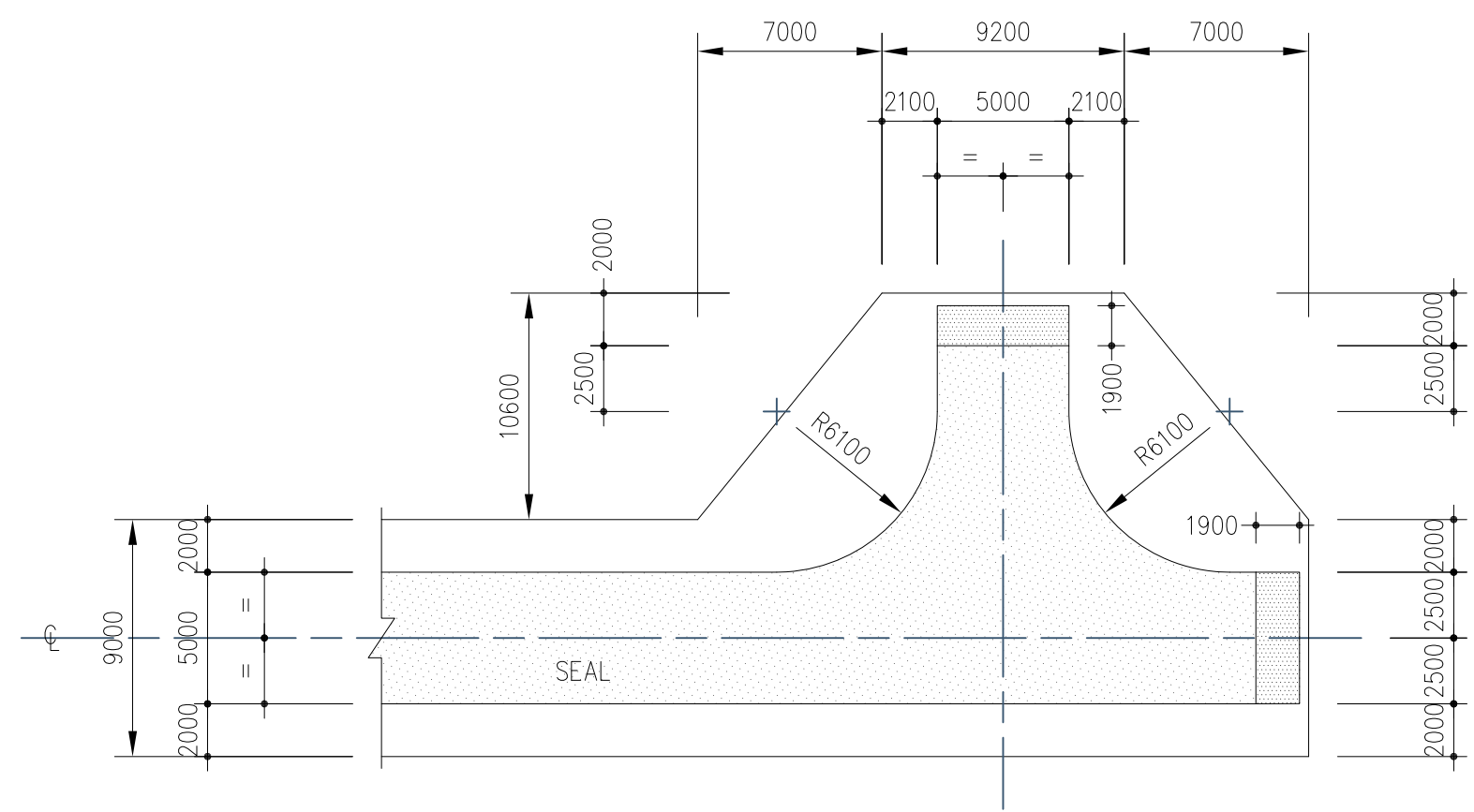
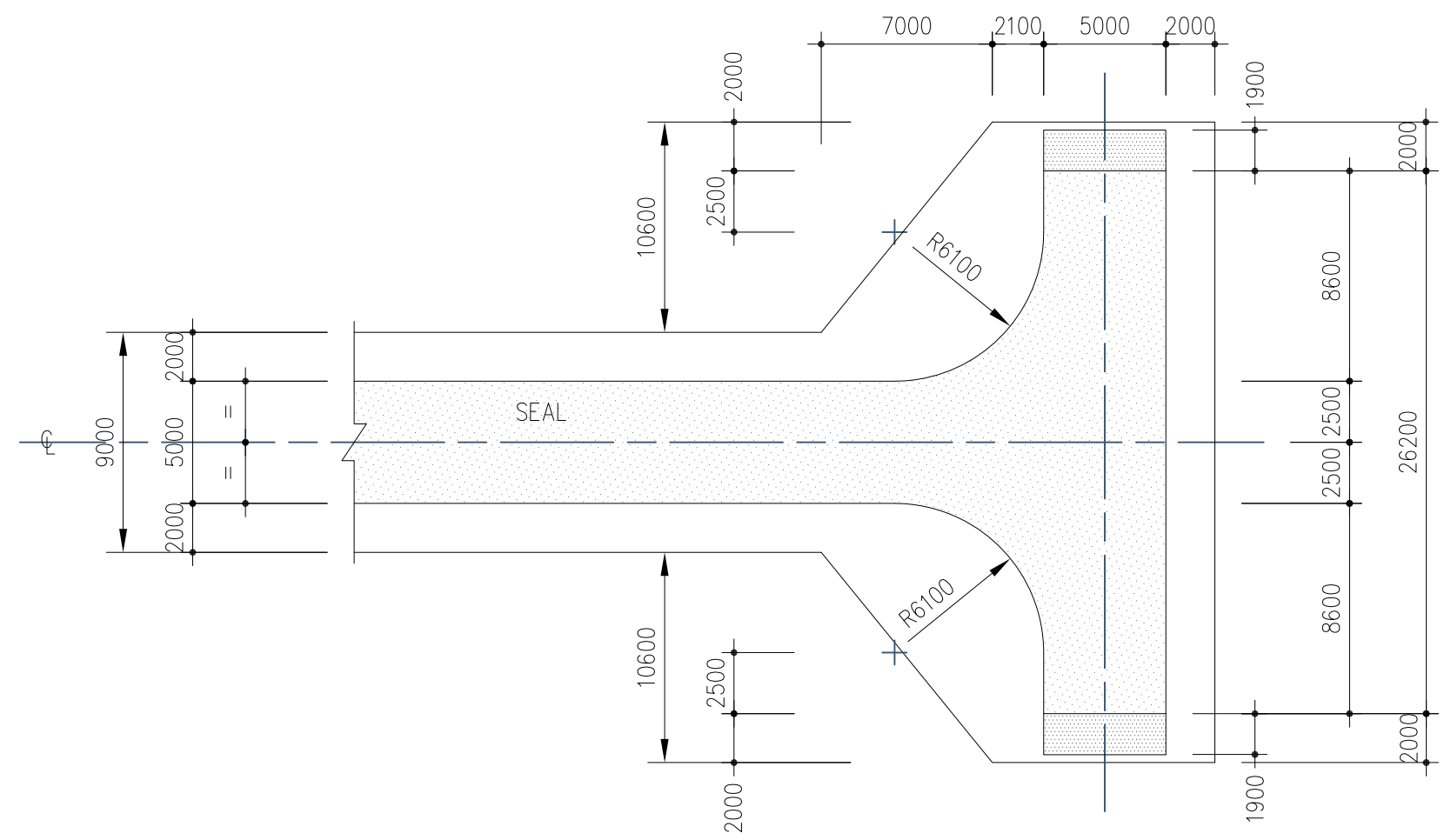

GENERAL NOTES  
 1. All dimensions are in mm  
 2. All dimensions to lip of Kerb and Channel  
 3. [Hatched Area] Vehicle overhang area to be kept clear of permanent fixed objects.

STANDARD DRAWINGS  
**CUL-DE-SAC TURNING HEADS FOR RESIDENTIAL 9.0M WIDE ROADS**



E				
D				
C				
B				
A				
ISSUE	APPD	DATE	AMENDMENT	BY

SCALE 1:100

DATE 02 MAY 17

DESIGN BY

DRAWN BY CWS

APPROVED A KETENILAGI

DRAWING No. R 100 - 2

SHEET No. 01

ISSUE

150  
100  
50  
40  
30  
20  
10

A3 ORIGINAL SIZE

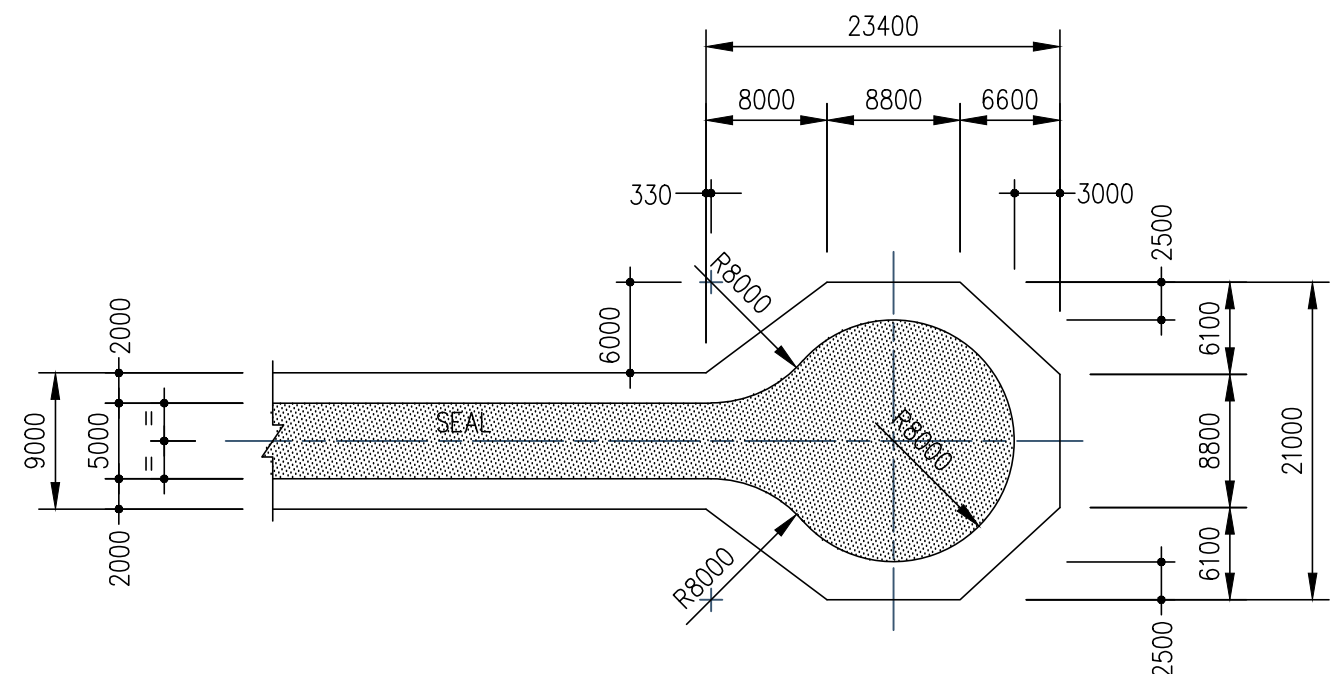
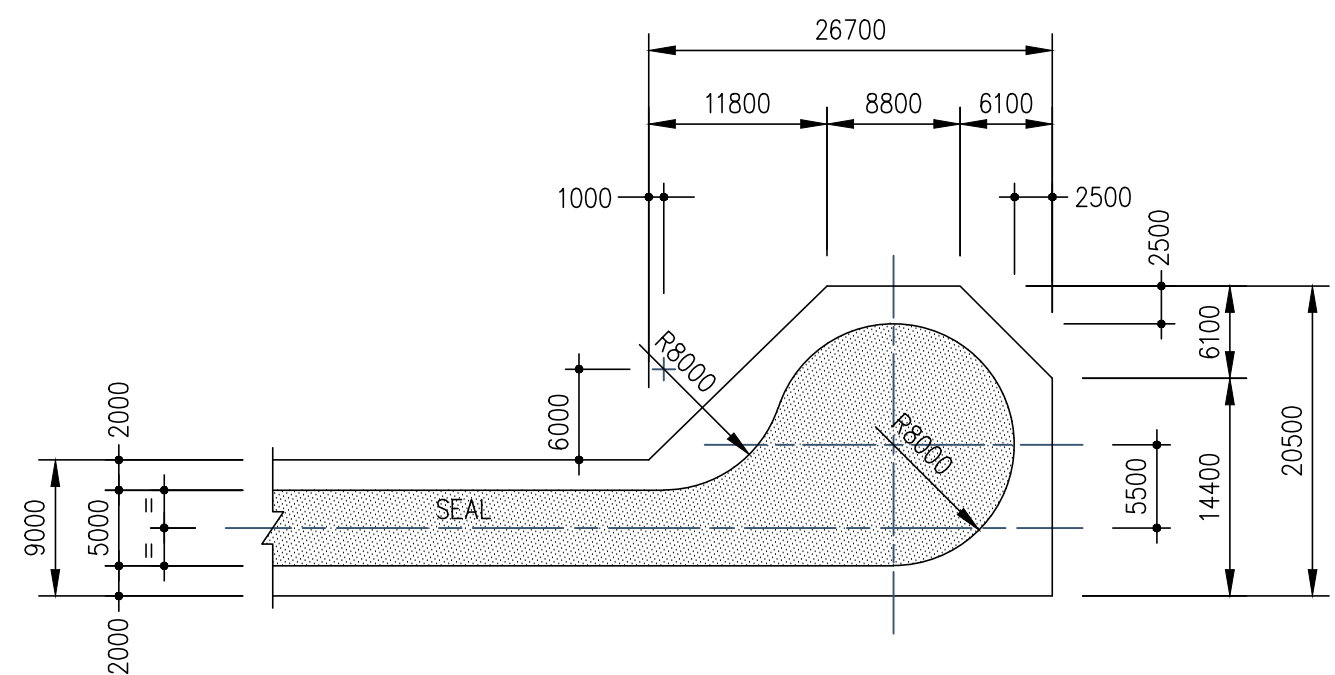

GENERAL NOTES  
 1. All dimensions are in mm  
 2. All dimensions to lip of Kerb and Channel  
 3. Current FRA practice is to provide a 9.5m radius for residential roads and 15m radius for commercial and industrial roads, Refer R100 drawings for design details

**STANDARD DRAWINGS**  
**CUL-DE-SAC TURNING HEADS FOR RESIDENTIAL 9.0M WIDE ROADS**

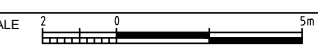
SCALE 1:100  DATE 02 MAY17 DESIGN BY

 **Fiji Roads Authority**

DRAWN BY CWS	APPROVED A KETENILAGI	DRAWING No. R 100 - 3	SHEET No. 01	ISSUE
-----------------	--------------------------	--------------------------	-----------------	-------

ISSUE	APP'D	DATE	AMENDMENT	BY
E				
D				
C				
B				
A				

150 PLOT DATE 18/10/2018

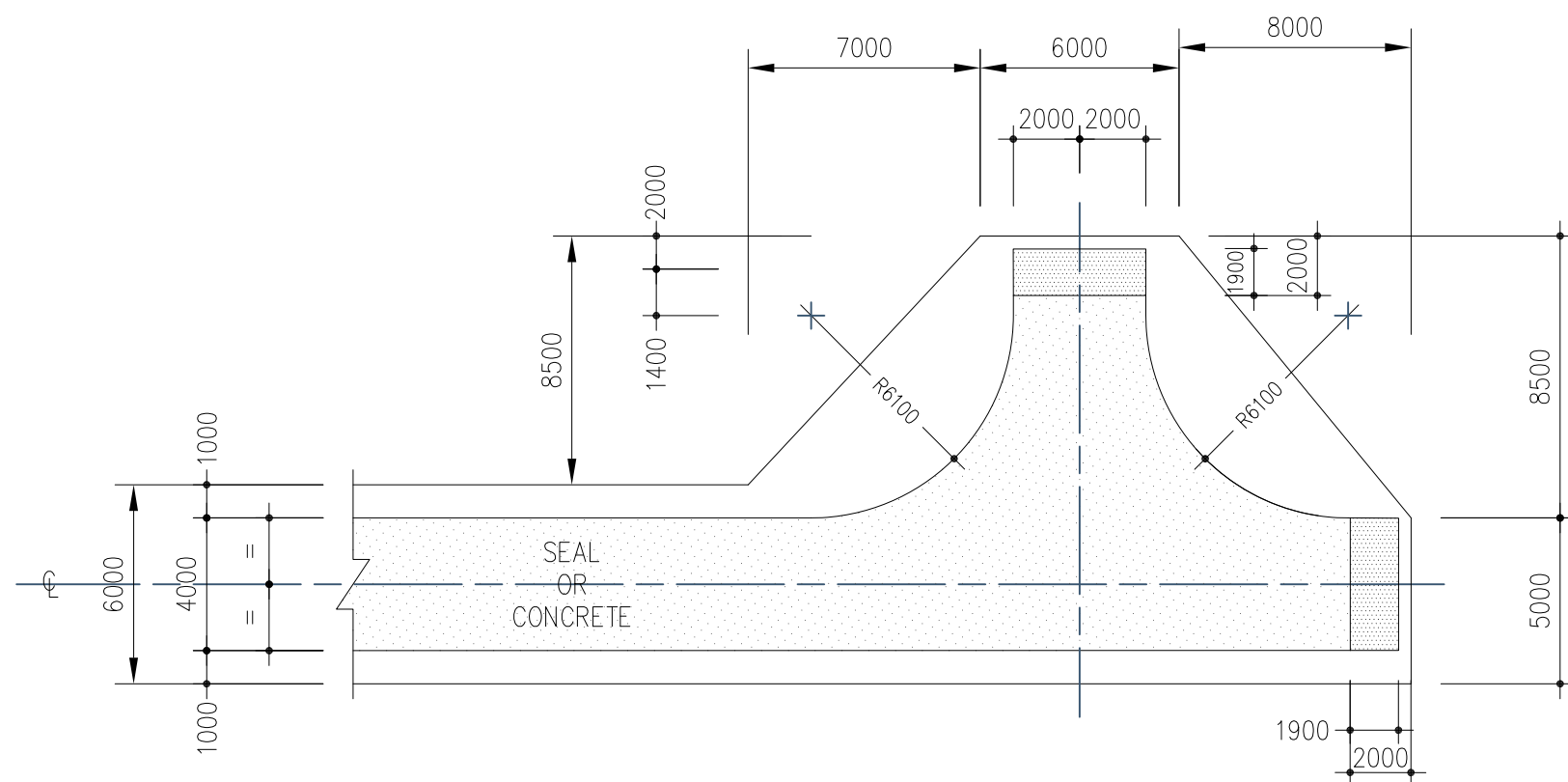
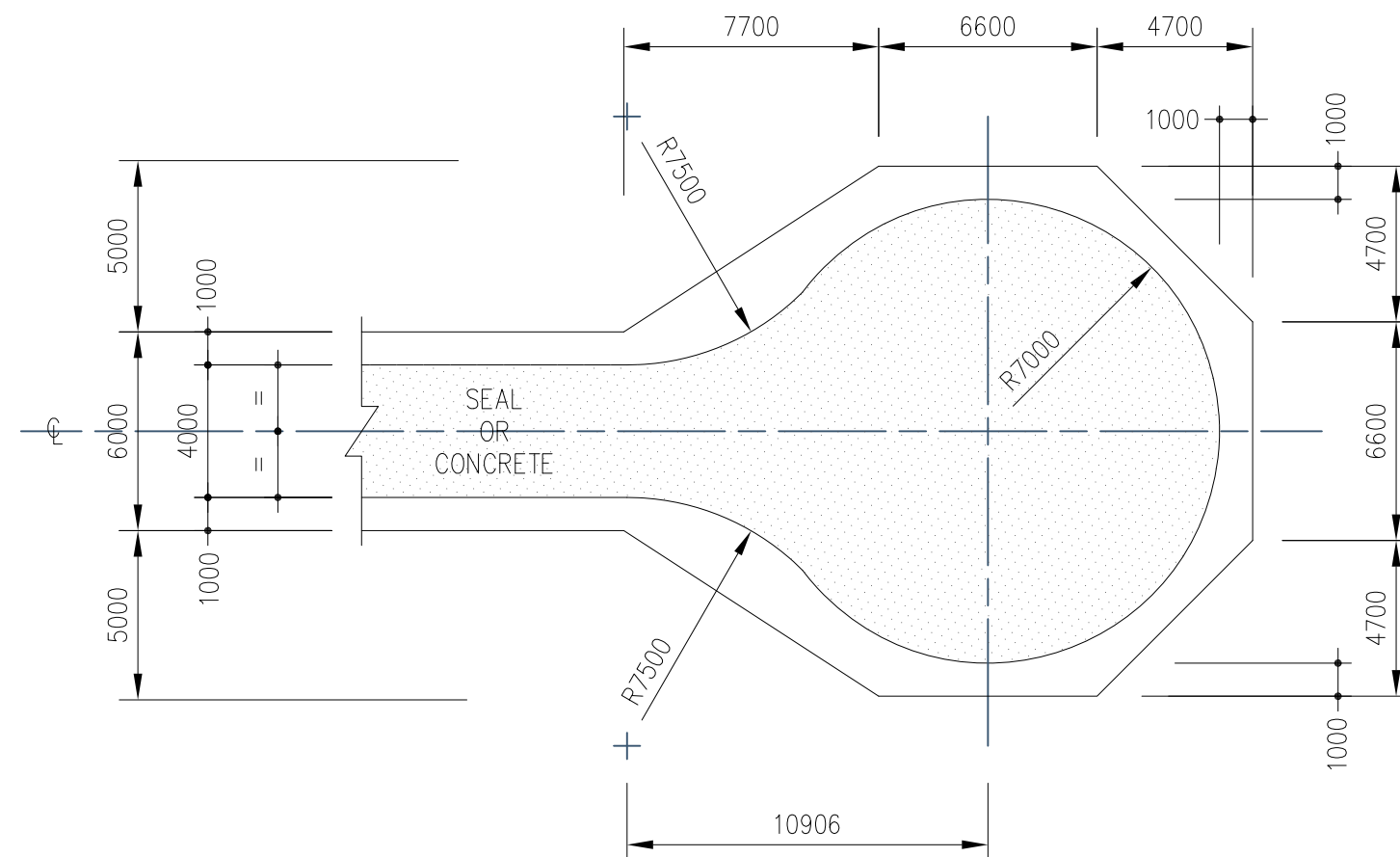
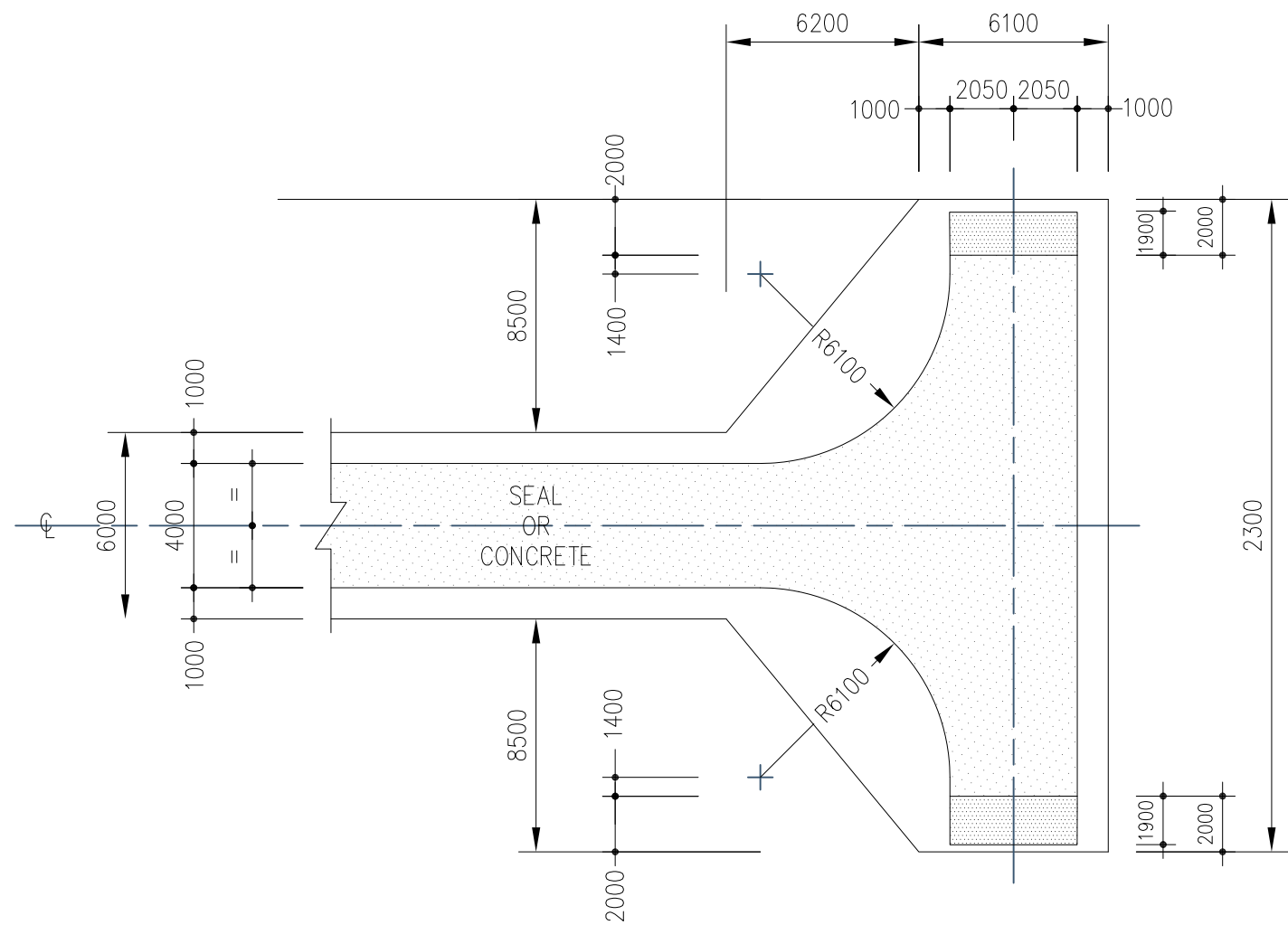

A3 ORIGINAL SIZE

E				
D				
C				
B				
A				
ISSUE	APPD	DATE	AMENDMENT	BY

GENERAL NOTES  
 1. All dimensions are in mm  
 2. All dimensions to lip of Kerb and Channel  
 3. Vehicle overhang area to be kept clear of permanent fixed objects.

STANDARD DRAWINGS  
**CUL-DE-SAC TURNING HEADS FOR RESIDENTIAL 6.0M WIDE ROADS**

SCALE 1:100

DATE 02 MAY 17

DESIGN BY

**Fiji Roads Authority**

DRAWN BY CWS

APPROVED A KETENILAGI

DRAWING No. R 100 - 4

SHEET No. 01

ISSUE

PLOT DATE 18/10/2018

150  
100  
50  
40  
30  
20  
10

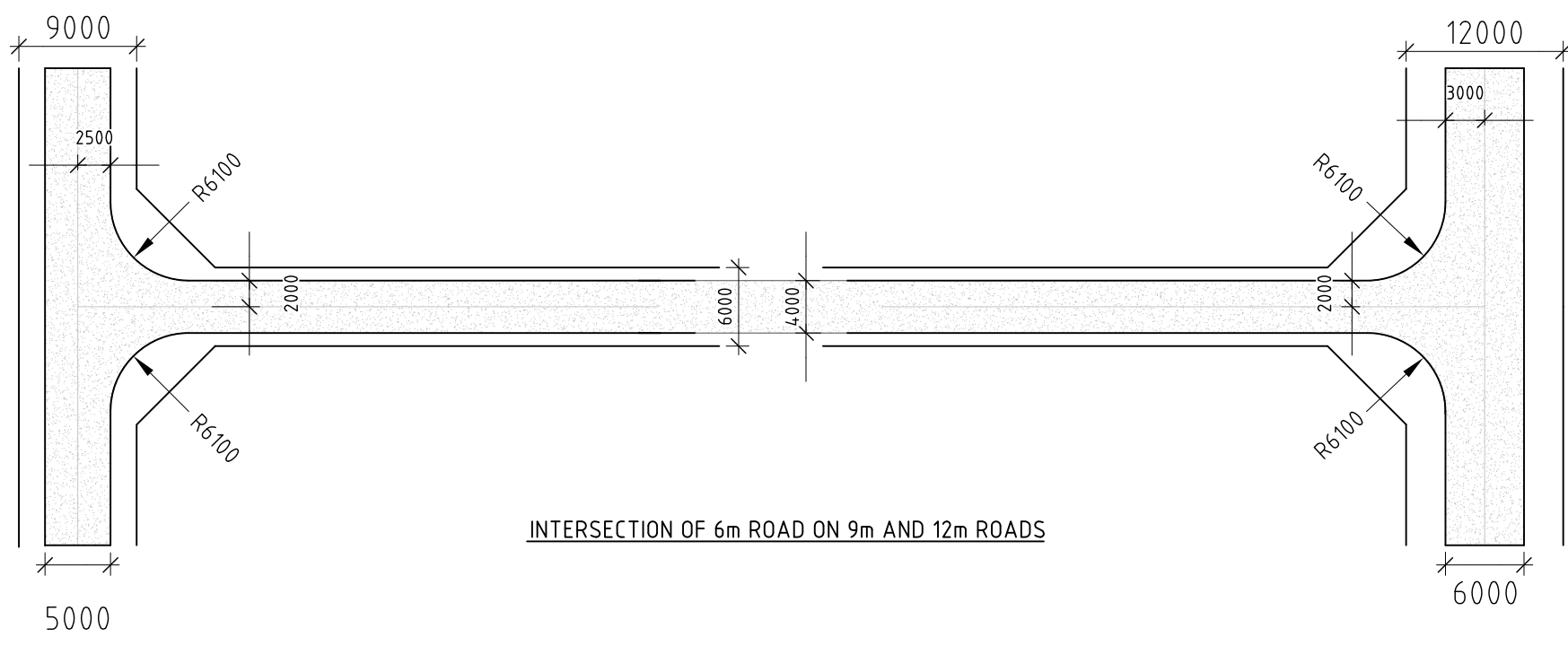

INTERSECTION OF 6m ROAD ON 9m AND 12m ROADS

A3 ORIGINAL SIZE

E				
D				
C				
B				
A				
ISSUE	APPD	DATE	AMENDMENT	BY

GENERAL NOTES  
 1. All dimensions are in mm  
 2. All dimensions to lip of Kerb and Channel

STANDARD DRAWINGS  
 INTERSECTION DETAILS  
 INTERSECTION OF 6m ROAD ON 9m AND 12m ROADS

SCALE SCALE 1:100

DATE 02 MAY 17

DESIGN BY

Fiji Roads Authority

DRAWN BY CWS

APPROVED A KETENILAGI

DRAWING No. R 100 - 5

SHEET No. 01

ISSUE A

PLOT DATE 18/10/2018

150

100

50

40

30

20

10

A3 ORIGINAL SIZE

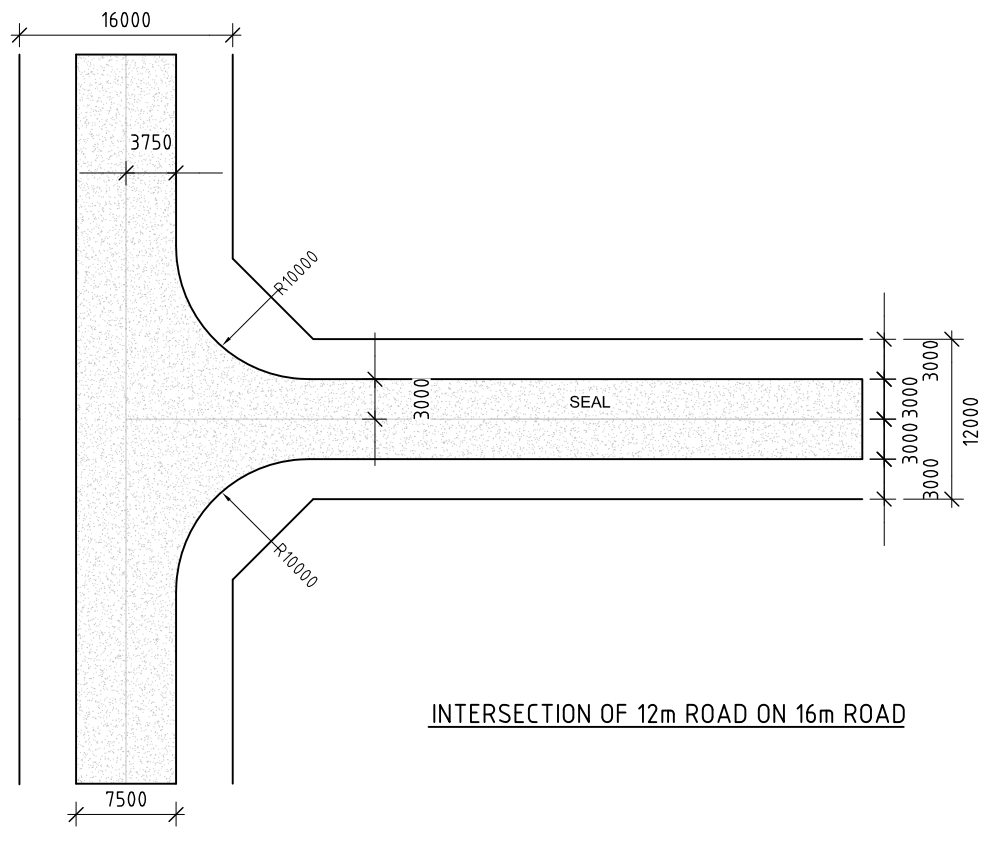
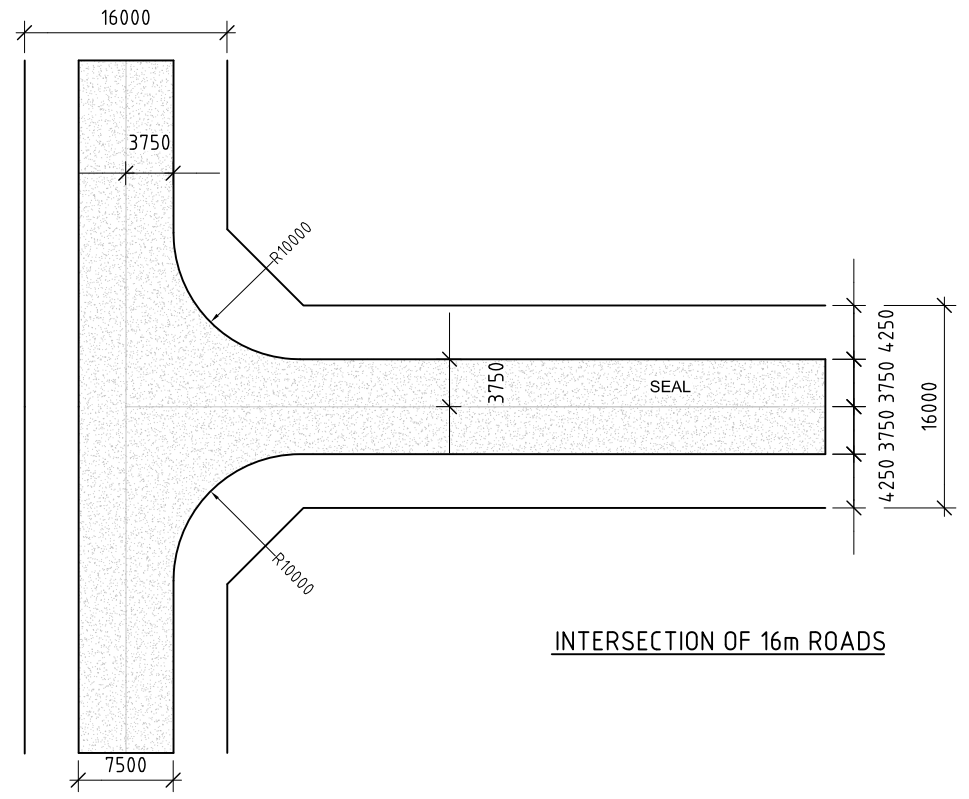

GENERAL NOTES

1. All dimensions are in mm
2. All dimensions to lip of Kerb and Channel

STANDARD DRAWINGS  
INTERSECTION DETAILS  
INTERSECTION OF 12m and 16m



E				
D				
C				
B				
A				
ISSUE	APPD	DATE	AMENDMENT	BY

SCALE	DATE	DESIGN BY	DRAWN BY	APPROVED	DRAWING No.	SHEET No.	ISSUE
	02 MAY 17		CWS	A KETENILAGI	R 100 - 6	01	A

150  
100  
50  
40  
30  
20  
10  
A3 ORIGINAL SIZE

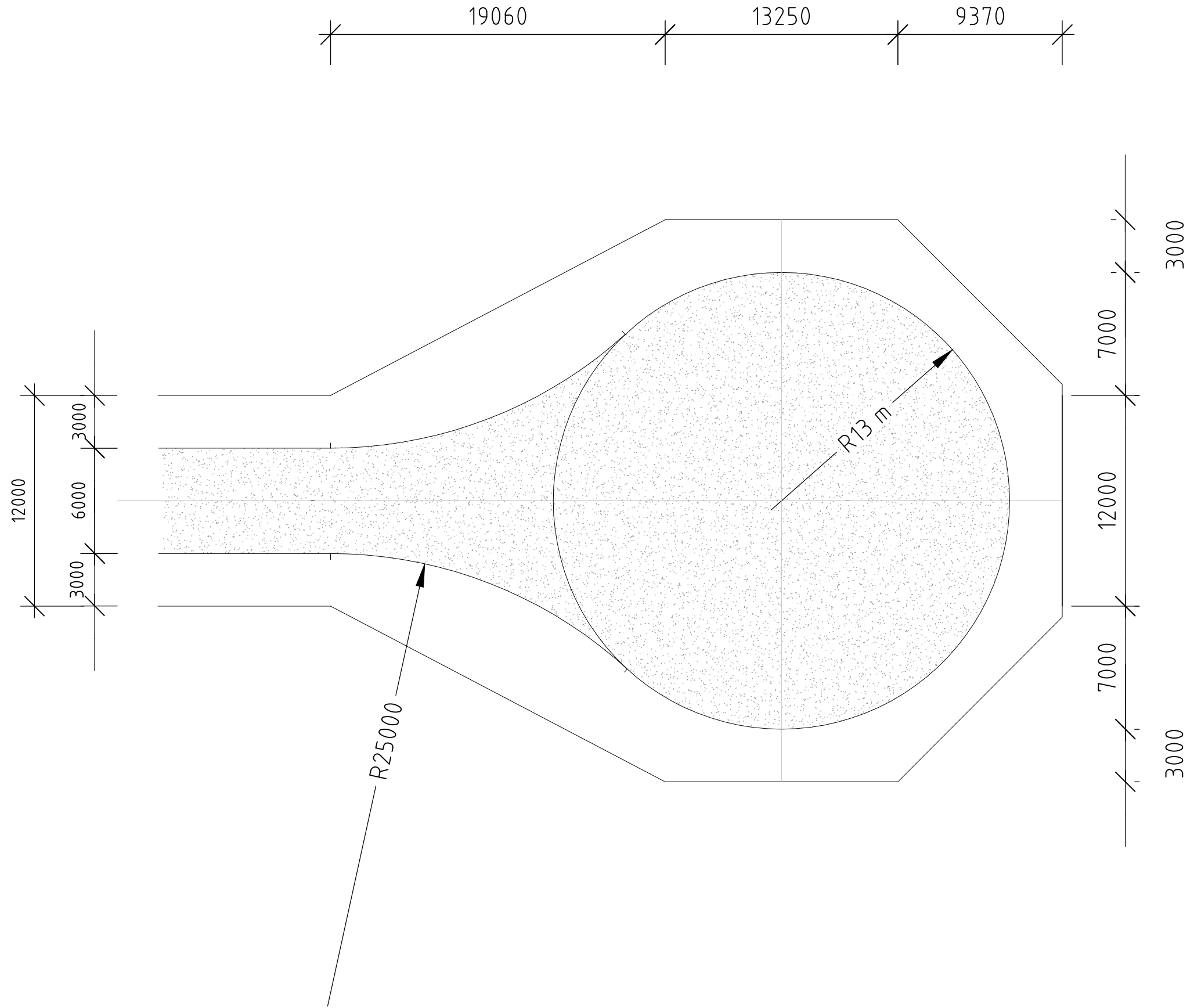

GENERAL NOTES

1. 13m radius to accommodate 8.8m Service Vehicles.
2. All dimensions are in millimeters
3. All dimensions to lip of Kerb and Channel
4. Current FRA practice is to provide a 9.5m radius for residential roads and 15m radius for commercial and industrial roads, Refer R100 drawings for design details

**STANDARD DRAWINGS**  
**RESIDENTIAL CUL-DE-SAC**  
**5m CAR / 8.8m SERVICE VEHICLE**



ISSUE	APP'D	DATE	AMENDMENT	BY
E				
D				
C				
B				
A				

SCALE	DATE	DESIGN BY	DRAWN BY	APPROVED	DRAWING No.	SHEET No.	ISSUE
	02 MAY 17		CWS	A KETENILAGI	R 100 - 7	01	A

PLOT DATE 10/06/2019

RADIUS TABLE	
RESIDENTIAL	8.0m- 9.5m
COMMERCIAL	15m
INDUSTRIAL	15m

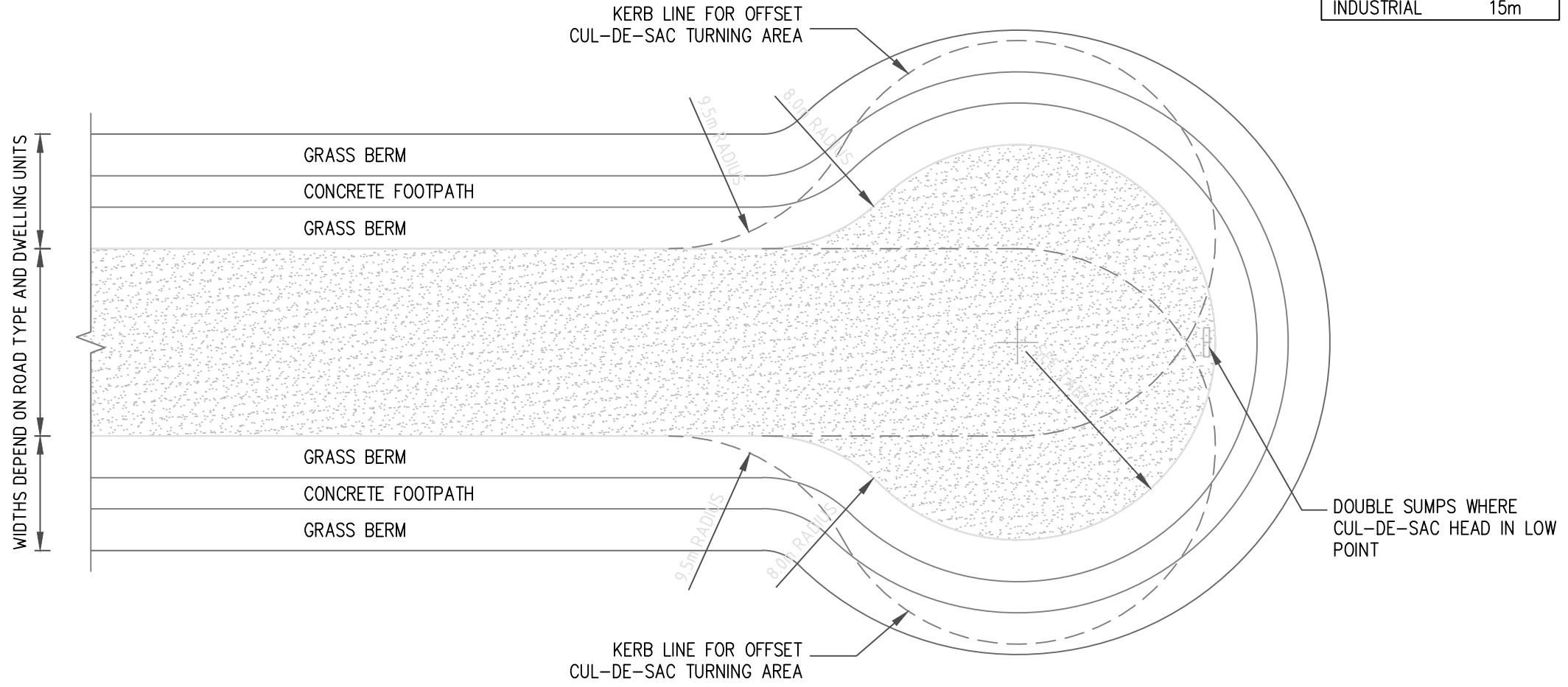

WIDTHS DEPEND ON ROAD TYPE AND DWELLING UNITS

ISSUE	APP'D	DATE	AMENDMENT	BY
E				
D				
C				
B				
A				

GENERAL NOTES  
 1. BASED ON NZS 4404:2010.

STANDARD DRAWINGS  
 GENERAL DESIGN STANDARD  
 FOR 8m AND 15m CUL-DE-SAC

Fiji Roads Authority

DRAWN BY S VOLAU	APPROVED A KETENILAGI	DRAWING No. R 100 - 8	SHEET No. 01	ISSUE A
---------------------	--------------------------	--------------------------	-----------------	------------

A3 ORIGINAL SIZE

# INDEX SHEET

## **SERIES 300      PAVEMENT CONSTRUCTION TYPICAL ROAD CROSS SECTIONS**

<b>DRAWING NUMBER</b>	<b>DRAWING TITLE</b>
R 300	TYPICAL CROSS SECTION SEALED MAIN ROAD
R 301	TYPICAL CROSS SECTION SEALED SECONDARY ROAD
R 302	TYPICAL CROSS SECTION SEALED SECONDARY SINGLE LANE ROAD
R 303	TYPICAL CROSS SECTION SEALED COUNTRY ROAD
R 304	TYPICAL CROSS SECTION SEALED COUNTRY SINGLE LANE ROAD
R 305	TYPICAL CROSS SECTION SEALED RESIDENTIAL SINGLE LANE ROAD
R 306	TYPICAL CROSS SECTION UNSEALED MAIN ROAD
R 307	TYPICAL CROSS SECTION UNSEALED SECONDARY AND COUNTRY ROAD
R 308	TYPICAL CROSS SECTION UNSEALED SINGLE LANE SECONDARY, COUNTRY & RESIDENTIAL ROAD
R 309	CONSTRUCTION OF VERGE ROUNDING DETAIL
R 310	TYPICAL CROSS SECTION URBAN ARTERIAL ROAD
R 311	TYPICAL CROSS SECTIONS URBAN LOCAL AND COLLECTOR STREET
R 312	TYPICAL RURAL ROAD CROSS SECTION LOW LEVEL RIVER / CREEK.
R 313	TYPICAL RURAL ROAD CROSS SECTION LOW LEVEL RIVER / CREEK.

**MINIMUM STANDARDS**  
**SEALED MAIN ROADS M1 & M2**

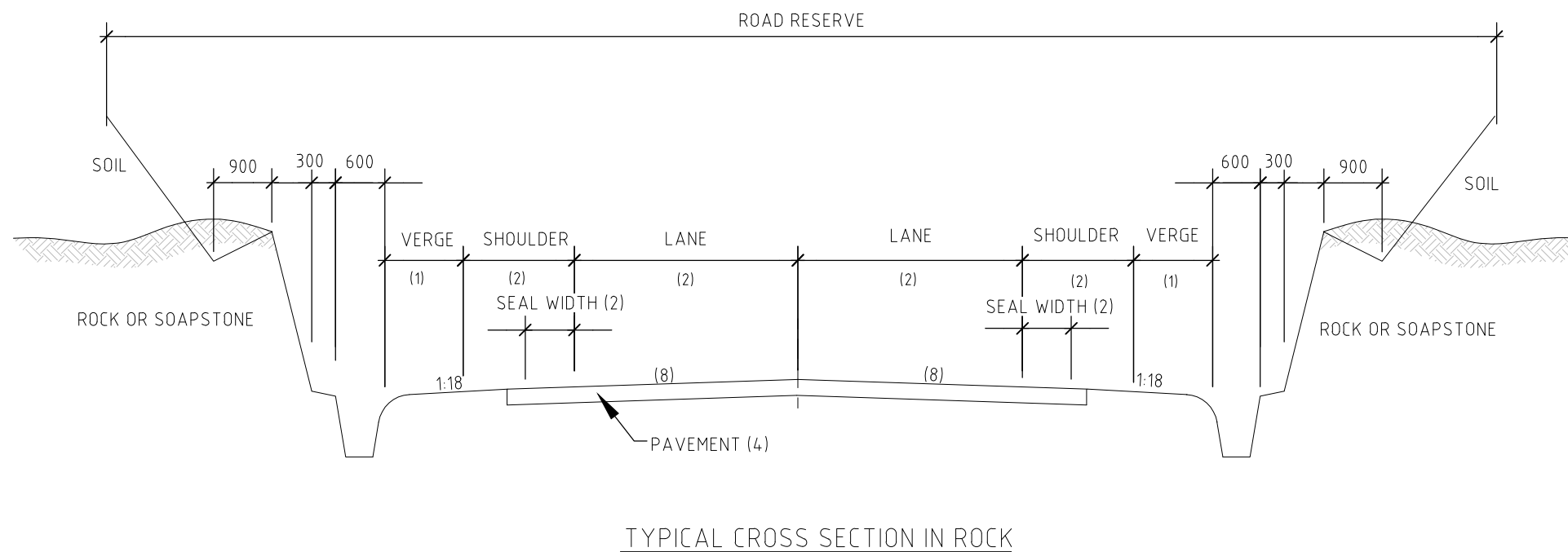
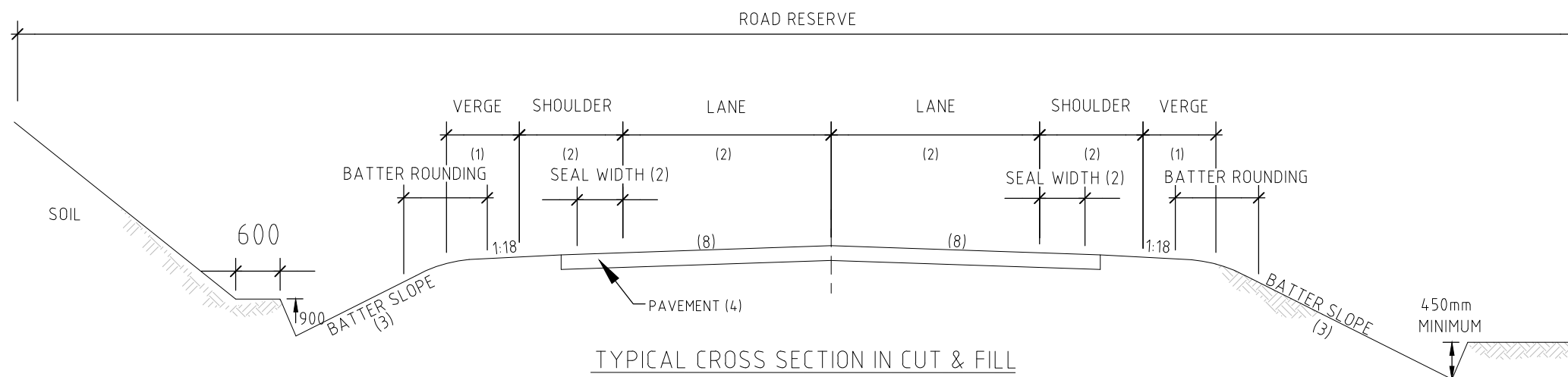
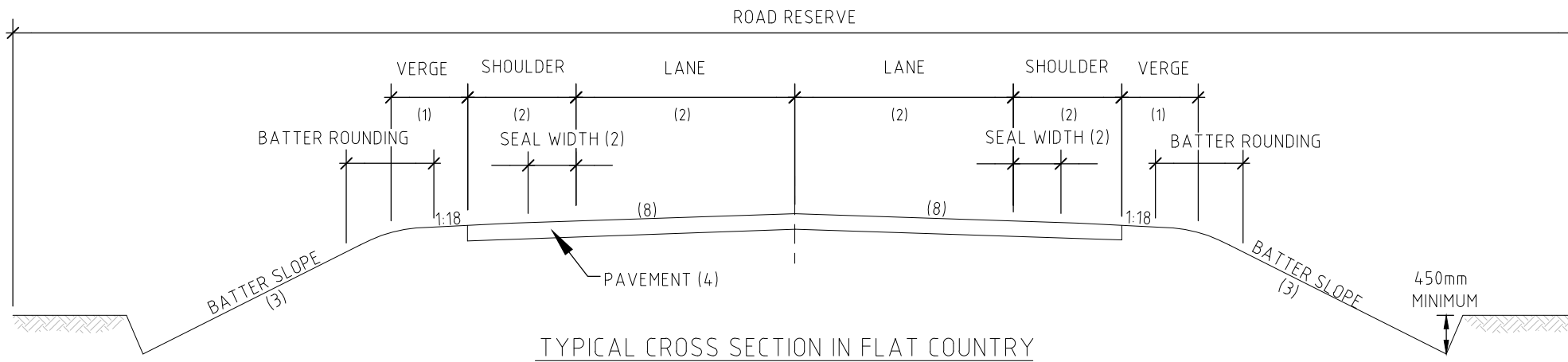

**NOTES:**

1. REFER AGRD PART3 SECTION 4.4.1 for VERGE WIDTH.
2. REFER FRA SUPPLEMENT TABLE V4.2 FOR SHOULDER WIDTH.
3. REFER AGRD PART 3 SECTION 4.6 AND FRA SUPPLEMENT CH 3 SECTION 4.5 FOR BATTER SLOPE.
4. PAVEMENT DESIGN AS PER FRA PAVEMENT DESIGN SUPPLEMENT.
5. INVERT SHALL BE A MINIMUM OF 150mm BELOW SUBGRADE
6. DRAINAGE DIMENSIONS ARE MINIMUM ONLY. REFER TO AGRD 5(b), SECTION 2.13 FOR DRAINAGE DESIGN.
7. REFER TO STANDARD DRAWING NUMBER R502-1 TO 3. FOR SUBSURFACE DRAINAGE DETAILS.
8. REFER AGRD, PART 3 SECTION 4.2.2 AND FRA SUPPLEMENT CH 3, SECTION 4.2.2 FOR PAVEMENT SCOPE
9. THESE DRAWINGS SHOW CROSS SECTION GEOMETRIC DETAILS ONLY. FOR DRAINAGE OF PAVEMENT LAYERS REFER TO ALTERNATIVE DETAILS AND DESIGN GUIDES

PLOT DATE 12/03/2019

150  
100  
50  
40  
30  
20  
10

A3 ORIGINAL SIZE	E					
	D					
	C					
	B					
	A					
ISSUE	APPD	DATE	AMENDMENT	BY	GENERAL NOTES	

GENERAL NOTES

STANDARD DRAWINGS		
TYPICAL ROAD CROSS SECTION MAIN ROADS		
SCALE	DATE	DESIGN BY
	30 MAR 17	

DRAWN BY	APPROVED	DRAWING No.	SHEET No.	ISSUE
CWS		R 300	01	A

**MINIMUM STANDARDS  
SEALED SECONDARY ROADS**

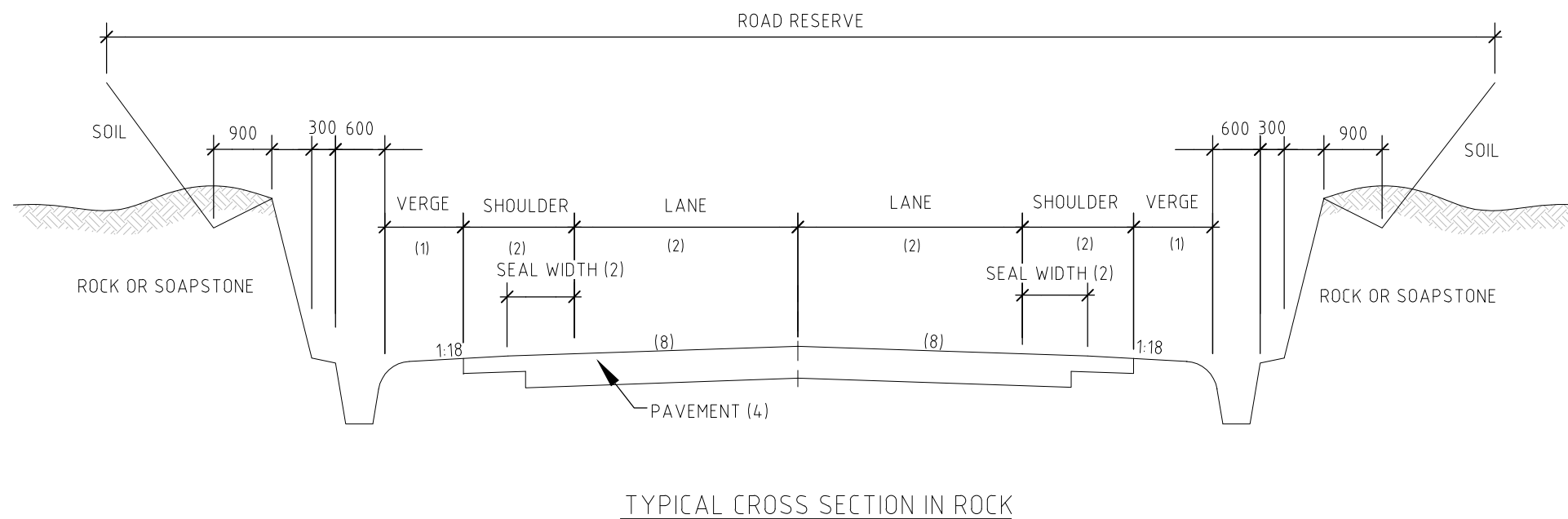
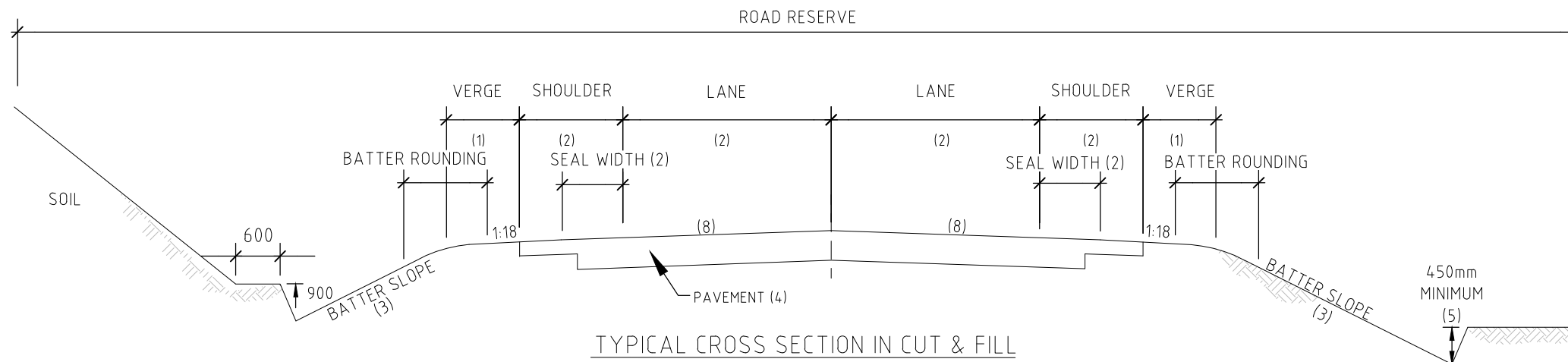
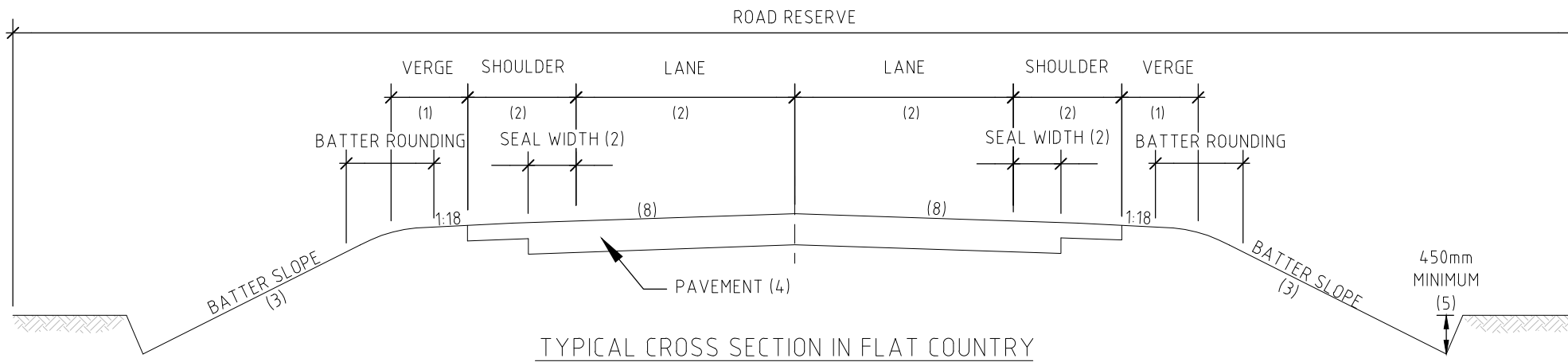

**NOTES:**

1. REFER AGRD PART3 SECTION 4.4.1 for VERGE WIDTH.
2. REFER FRA SUPPLEMENT TABLE V4.2 FOR SHOULDER WIDTH.
3. REFER AGRD PART 3 SECTION 4.6 AND FRA SUPPLEMENT CH 3 SECTION 4.5 FOR BATTER SLOPE.
4. PAVEMENT DESIGN AS PER FRA PAVEMENT DESIGN SUPPLEMENT.
5. INVERT SHALL BE A MINIMUM ONLY. REFER TO A BELOW SUBGRADE LEVEL.
6. DRAINAGE DIMENSIONS ARE MINIMUM ONLY. REFER TO AGRD 5(b), SECTION 2.13 FOR DRAINAGE DESIGN.
7. REFER TO STANDARD DRAWING NUMBER R502-1 TO 3. FOR SUBSURFACE DRAINAGE DETAILS.
8. REFER AGRD, PART 3 SECTION 4.2.2 AND FRA SUPPLEMENT CH 3, SECTION 4.2.2 FOR PAVEMENT SCOPE
9. THESE DRAWINGS SHOW CROSS SECTION GEOMETRIC DETAILS ONLY. FOR DRAINAGE OF PAVEMENT LAYERS REFER TO ALTERNATIVE DETAILS AND DESIGN GUIDES

PLOT DATE 12/03/2019

150  
100  
50  
40  
30  
20  
10

A3 ORIGINAL SIZE	E				
	D				
	C				
	B				
	A				
ISSUE	APP'D	DATE	AMENDMENT	BY	

GENERAL NOTES

<b>STANDARD DRAWINGS</b>		
<b>TYPICAL ROAD CROSS SECTION SEALED SECONDARY ROADS</b>		
SCALE	DATE 30 MAR 17	DESIGN BY

**Fiji Roads Authority**

DRAWN BY CWS	APPROVED	DRAWING No. R 301	SHEET No. 01	ISSUE A
-----------------	----------	----------------------	-----------------	------------

**MINIMUM STANDARDS**  
**SEALED SECONDARY ROADS SINGLE LANE CROSS SECTION**

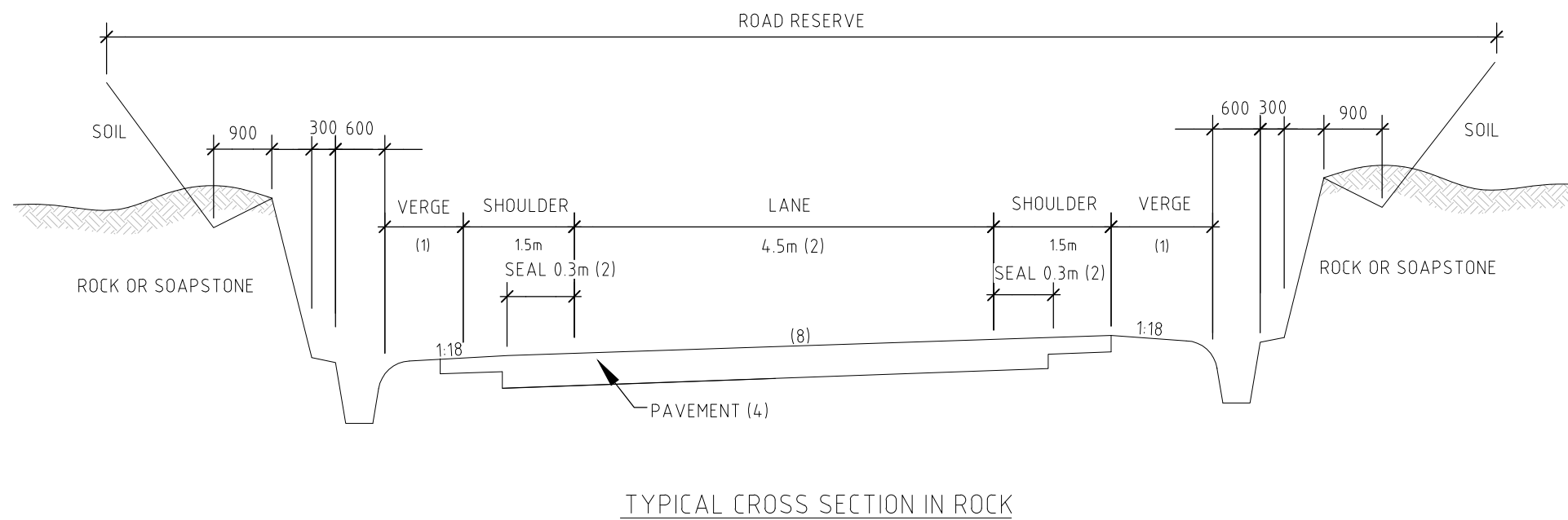
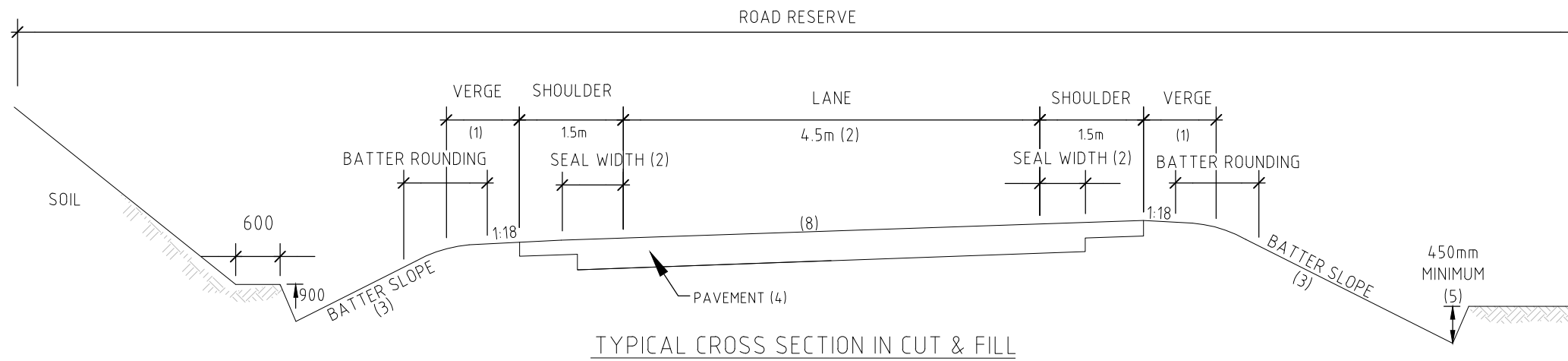
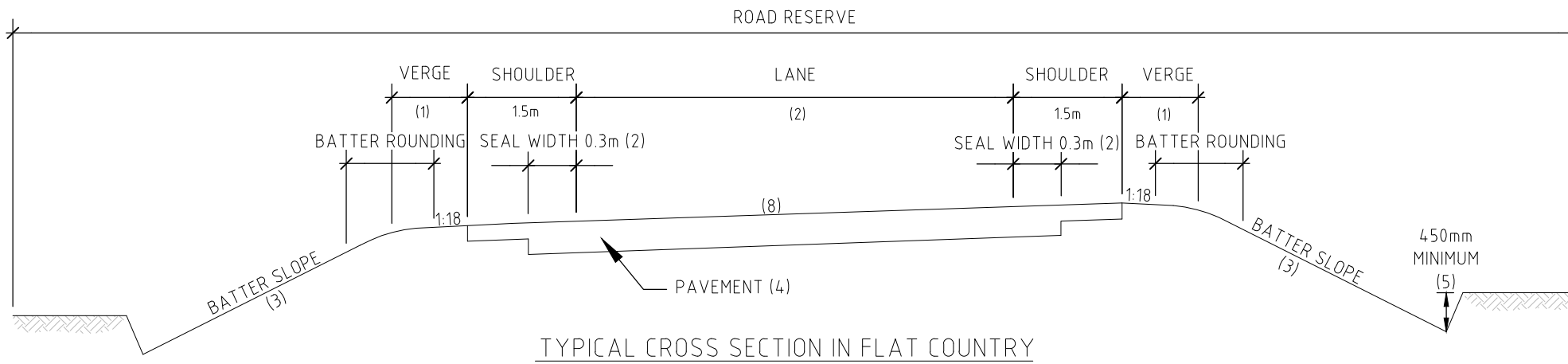

**NOTES:**

1. REFER AGRD PART3 SECTION 4.4.1 for VERGE WIDTH.
2. REFER FRA SUPPLEMENT TABLE V4.2 FOR SHOULDER WIDTH.
3. REFER AGRD PART 3 SECTION 4.6 AND FRA SUPPLEMENT CH 3 SECTION 4.5 FOR BATTER SLOPE.
4. PAVEMENT DESIGN AS PER FRA PAVEMENT DESIGN SUPPLEMENT.
5. INVERT SHALL BE A MINIMUM ONLY. REFER TO A BELOW SUBGRADE LEVEL.
6. DRAINAGE DIMENSIONS ARE MINIMUM ONLY. REFER TO AGRD 5(b), SECTION 2.13 FOR DRAINAGE DESIGN.
7. REFER TO STANDARD DRAWING NUMBER R502-1 TO 3. FOR SUBSURFACE DRAINAGE DETAILS.
8. REFER AGRD, PART 3 SECTION 4.2.2 AND FRA SUPPLEMENT CH 3, SECTION 4.2.2 FOR PAVEMENT SCOPE
9. FRA CURRENT POLICY IS TO NOT CONSTRUCT SINGLE LANE ROADS, HOWEVER, THIS TYPICAL CROSS SECTION IS PROVIDED AS AN APPROPRIATE STANDARD FOR SINGLE LANE ROADS IN FIJI
10. THESE DRAWINGS SHOW CROSS SECTION GEOMETRIC DETAILS ONLY. FOR DRAINAGE OF PAVEMENT LAYERS REFER TO ALTERNATIVE DETAILS AND DESIGN GUIDES

PLOT DATE 12/03/2019

150  
100  
50  
40  
30  
20  
10

A3 ORIGINAL SIZE	E				
	D				
	C				
	B				
	A				
ISSUE	APPD	DATE	AMENDMENT	BY	

GENERAL NOTES

**STANDARD DRAWINGS**  
**TYPICAL ROAD CROSS SECTION**  
**SEALED SECONDARY ROADS, SINGLE LANE CROSS SECTION**

SCALE: DATE: 30 MAR 17 DESIGN BY: DRAWN BY: CWS APPROVED: DRAWING No. R 302 SHEET No. 01 ISSUE A

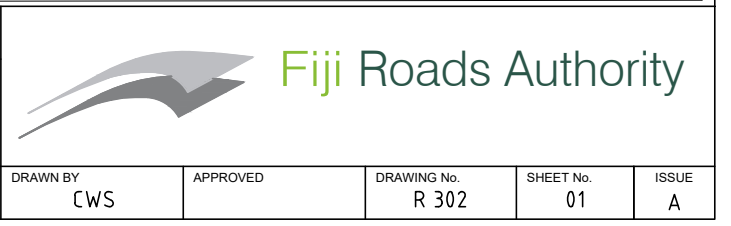

# MINIMUM STANDARDS SEALED COUNTRY ROADS

## NOTES:

1. REFER AGRD PART3 SECTION 4.4.1 for VERGE WIDTH.
2. REFER FRA SUPPLEMENT TABLE V4.2 FOR SHOULDER WIDTH.
3. REFER AGRD PART 3 SECTION 4.6 AND FRA SUPPLEMENT CH 3 SECTION 4.5 FOR BATTER SLOPE.
4. PAVEMENT DESIGN AS PER FRA PAVEMENT DESIGN SUPPLEMENT.
5. INVERT SHALL BE A MINIMUM ONLY. REFER TO A BELOW SUBGRADE LEVEL.
6. DRAINAGE DIMENSIONS ARE MINIMUM ONLY. REFER TO AGRD 5(b), SECTION 2.13 FOR DRAINAGE DESIGN.
7. REFER TO STANDARD DRAWING NUMBER R502-1 TO 3. FOR SUBSURFACE DRAINAGE DETAILS.
8. REFER AGRD, PART 3 SECTION 4.2.2 AND FRA SUPPLEMENT CH 3, SECTION 4.2.2 FOR PAVEMENT SCOPE
9. THESE DRAWINGS SHOW CROSS SECTION GEOMETRIC DETAILS ONLY. FOR DRAINAGE OF PAVEMENT LAYERS REFER TO ALTERNATIVE DETAILS AND DESIGN GUIDES

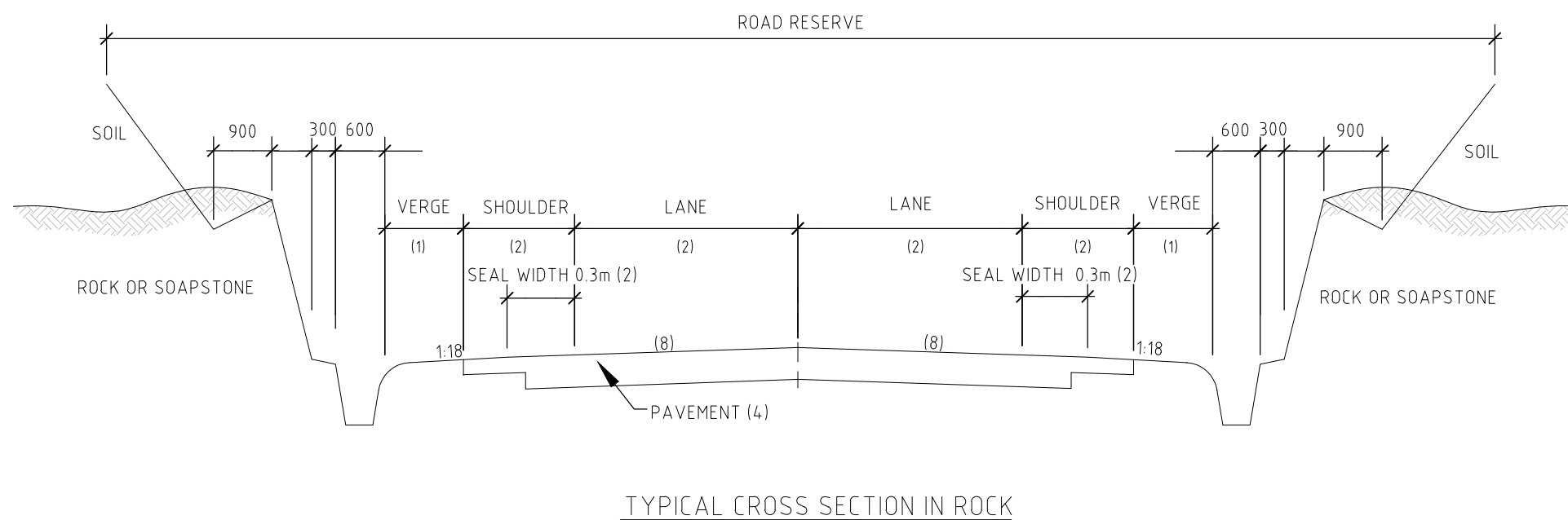
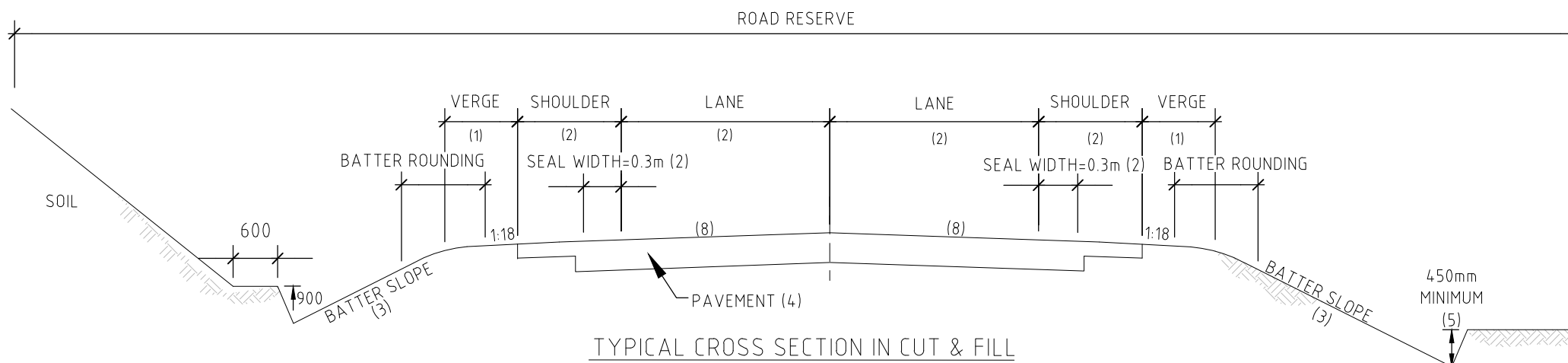
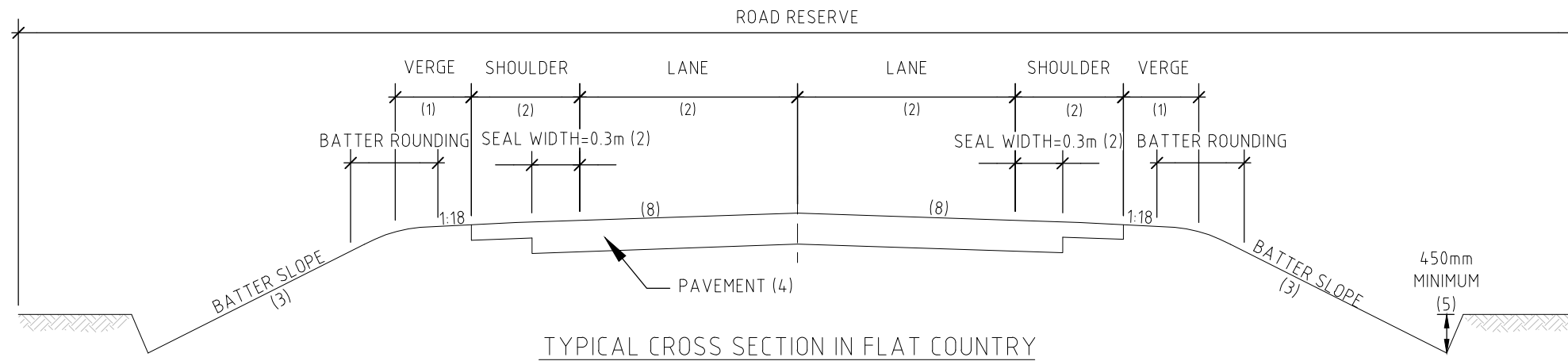

PLOT DATE 12/03/2019

150  
100  
50  
40  
30  
20  
10

ISSUE	APP'D	DATE	AMENDMENT	BY
E				
D				
C				
B				
A				

GENERAL NOTES

**STANDARD DRAWINGS**  
**TYPICAL ROAD CROSS SECTION**  
**SEALED COUNTRY ROADS**

SCALE: \_\_\_\_\_ DATE: 30 MAR 17 DESIGN BY: \_\_\_\_\_

Fiji Roads Authority

DRAWN BY	APPROVED	DRAWING No.	SHEET No.	ISSUE
CWS		R 303	01	A

**TYPICAL CROSS SECTION  
SEALED COUNTRY SINGLE LANE ROADS**

**NOTES:**

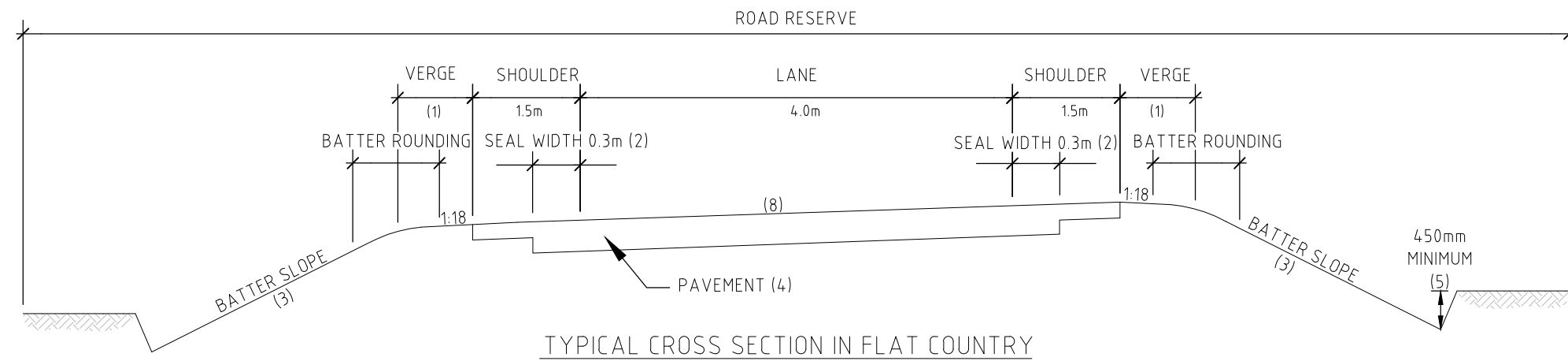

TYPICAL CROSS SECTION IN FLAT COUNTRY

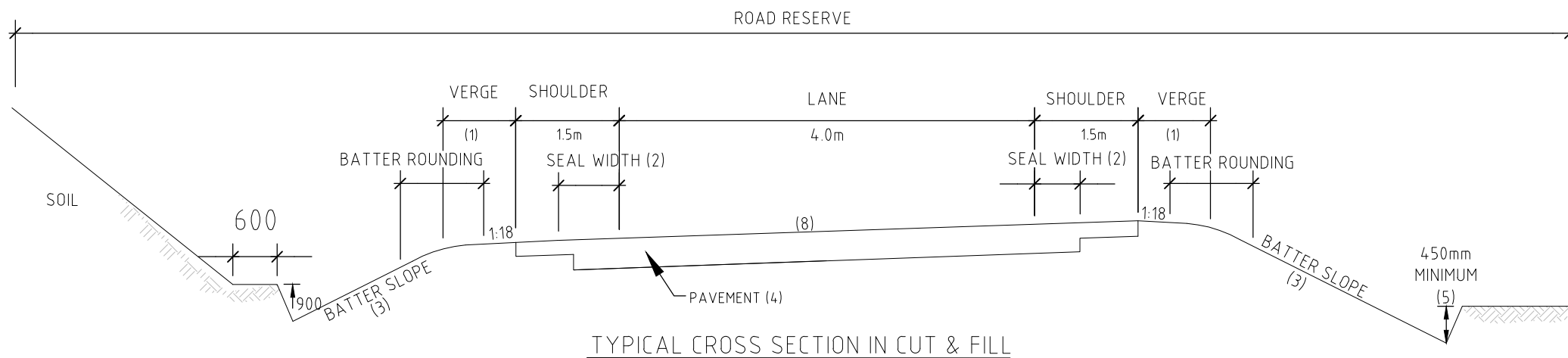

TYPICAL CROSS SECTION IN CUT & FILL

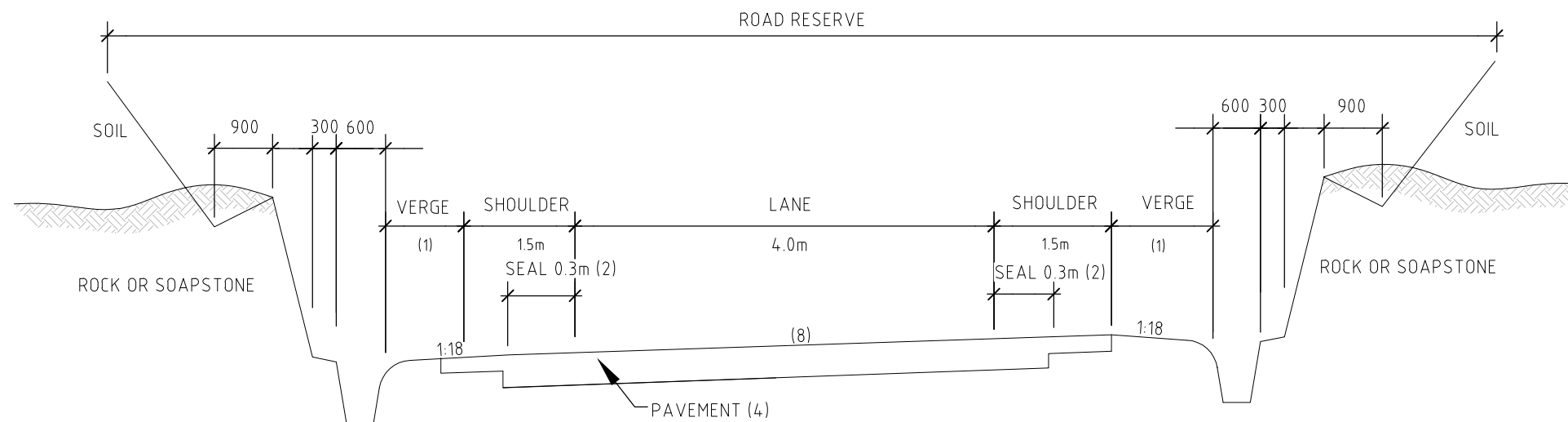

TYPICAL CROSS SECTION IN ROCK

1. REFER AGRD PART 3 SECTION 4.4.1 for VERGE WIDTH.
2. REFER FRA SUPPLEMENT TABLE V4.2 FOR SHOULDER WIDTH.
3. REFER AGRD PART 3 SECTION 4.6 AND FRA SUPPLEMENT CH 3 SECTION 4.5 FOR BATTER SLOPE.
4. PAVEMENT DESIGN AS PER FRA PAVEMENT DESIGN SUPPLEMENT.
5. INVERT SHALL BE A MINIMUM ONLY. REFER TO A BELOW SUBGRADE LEVEL.
6. DRAINAGE DIMENSIONS ARE MINIMUM ONLY. REFER TO AGRD 5(b), SECTION 2.13 FOR DRAINAGE DESIGN.
7. REFER TO STANDARD DRAWING NUMBER R502-1 TO 3. FOR SUBSURFACE DRAINAGE DETAILS.
8. REFER AGRD, PART 3 SECTION 4.2.2 AND FRA SUPPLEMENT CH 3, SECTION 4.2.2 FOR PAVEMENT SCOPE
9. FRA CURRENT POLICY IS TO NOT CONSTRUCT SINGLE LANE ROADS, HOWEVER, THIS TYPICAL CROSS SECTION IS PROVIDED AS AN APPROPRIATE STANDARD FOR SINGLE LANE ROADS IN FIJI
10. THESE DRAWINGS SHOW CROSS SECTION GEOMETRIC DETAILS ONLY. FOR DRAINAGE OF PAVEMENT LAYERS REFER TO ALTERNATIVE DETAILS AND DESIGN GUIDES

PLOT DATE 12/03/2019

150

100

50

40

30

20

10

A3 ORIGINAL SIZE

ISSUE	APPD	DATE	AMENDMENT	BY
E				
D				
C				
B				
A				

GENERAL NOTES

STANDARD DRAWINGS		
TYPICAL CROSS SECTION SEALED COUNTRY ROADS, SINGLE LANE CROSS SECTION		
SCALE	DATE	DESIGN BY
	30 MAR 17	

**Fiji Roads Authority**

DRAWN BY CWS	APPROVED	DRAWING No. R 304	SHEET No. 01	ISSUE A
-----------------	----------	----------------------	-----------------	------------

# TYPICAL CROSS SECTION SEALED RESIDENTIAL SINGLE LANE ROADS CROSS SECTION

## NOTES:

1. REFER AGRD PART3 SECTION 4.4.1 for VERGE WIDTH.
2. REFER FRA SUPPLEMENT TABLE V4.2 FOR SHOULDER WIDTH.
3. REFER AGRD PART 3 SECTION 4.6 AND FRA SUPPLEMENT CH 3 SECTION 4.5 FOR BATTER SLOPE.
4. PAVEMENT DESIGN AS PER FRA PAVEMENT DESIGN SUPPLEMENT.
5. INVERT SHALL BE A MINIMUM ONLY. REFER TO A BELOW SUBGRADE LEVEL.
6. DRAINAGE DIMENSIONS ARE MINIMUM ONLY. REFER TO AGRD 5(b), SECTION 2.13 FOR DRAINAGE DESIGN.
7. REFER TO STANDARD DRAWING NUMBER R502-1 TO 3. FOR SUBSURFACE DRAINAGE DETAILS.
8. REFER AGRD, PART 3 SECTION 4.2.2 AND FRA SUPPLEMENT CH 3, SECTION 4.2.2 FOR PAVEMENT SCOPE
9. FRA CURRENT POLICY IS TO NOT CONSTRUCT SINGLE LANE ROADS, HOWEVER, THIS TYPICAL CROSS SECTION IS PROVIDED AS AN APPROPRIATE STANDARD FOR SINGLE LANE ROADS IN FIJI
10. THESE DRAWINGS SHOW CROSS SECTION GEOMETRIC DETAILS ONLY. FOR DRAINAGE OF PAVEMENT LAYERS REFER TO ALTERNATIVE DETAILS AND DESIGN GUIDES

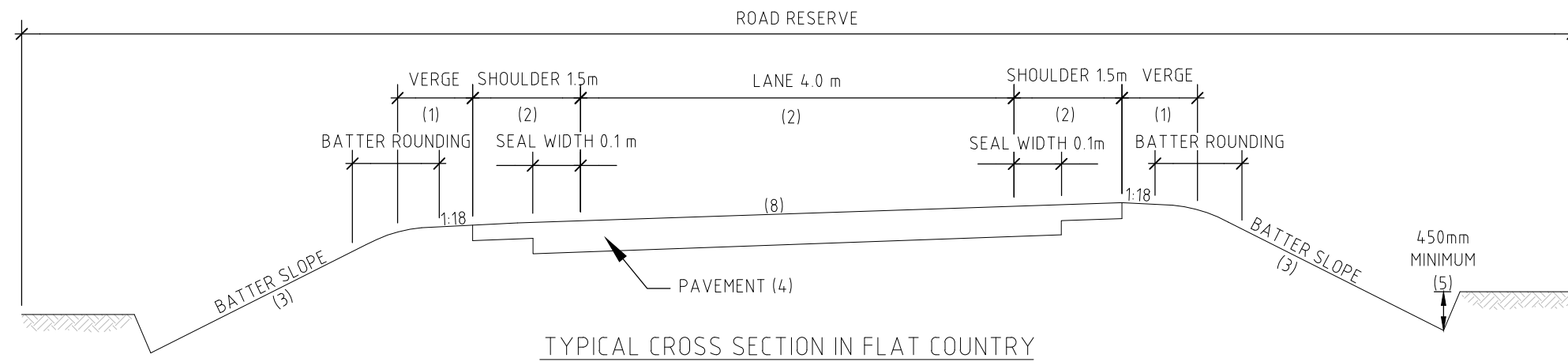

TYPICAL CROSS SECTION IN FLAT COUNTRY

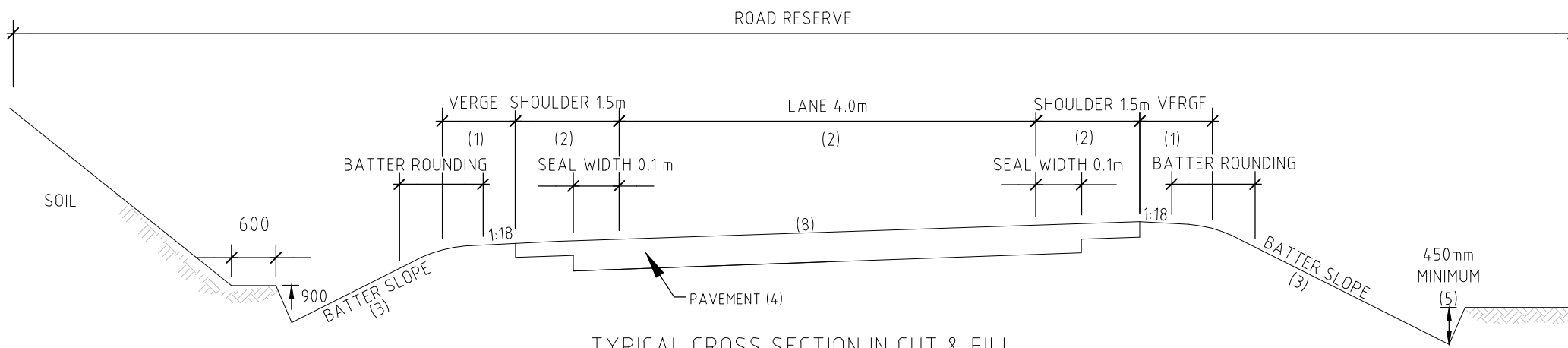

TYPICAL CROSS SECTION IN CUT & FILL

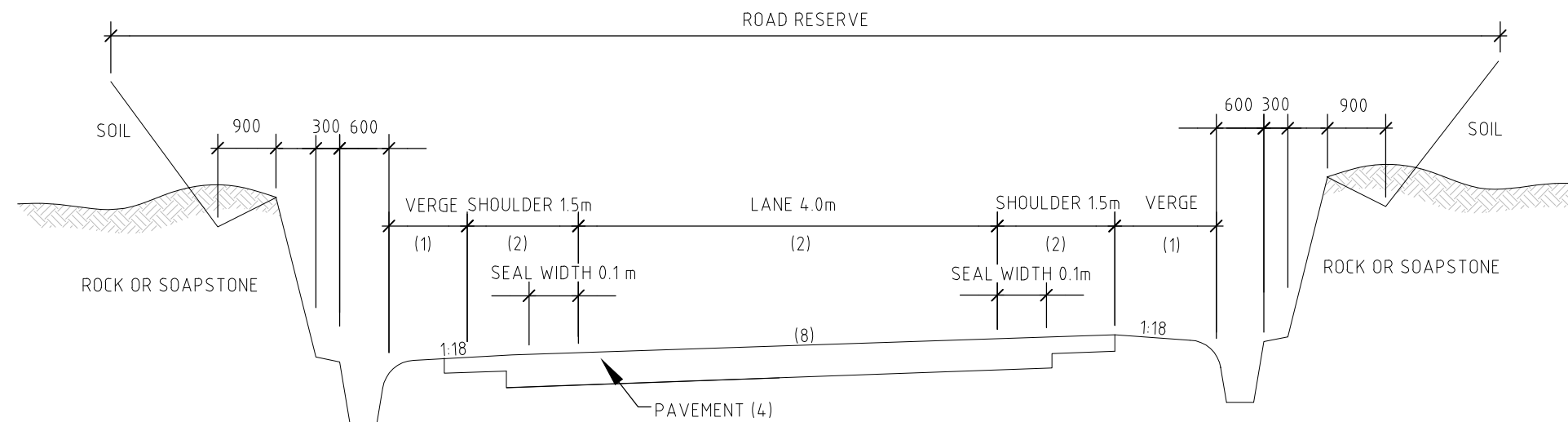

TYPICAL CROSS SECTION IN ROCK

PLOT DATE 12/03/2019

150  
100  
50  
40  
30  
20  
10

ISSUE	APP'D	DATE	AMENDMENT	BY
E				
D				
C				
B				
A				

GENERAL NOTES

STANDARD DRAWINGS		
TYPICAL CROSS SECTION SEALED RESIDENTIAL ROADS, SINGLE LANE CROSS SECTION		
SCALE	DATE	DESIGN BY
	30 MAR 17	

DRAWN BY  
CWS

APPROVED

DRAWING No.  
R 305

SHEET No.  
01

ISSUE  
A

**TYPICAL CROSS SECTION  
UNSEALED MAIN ROADS - M2**

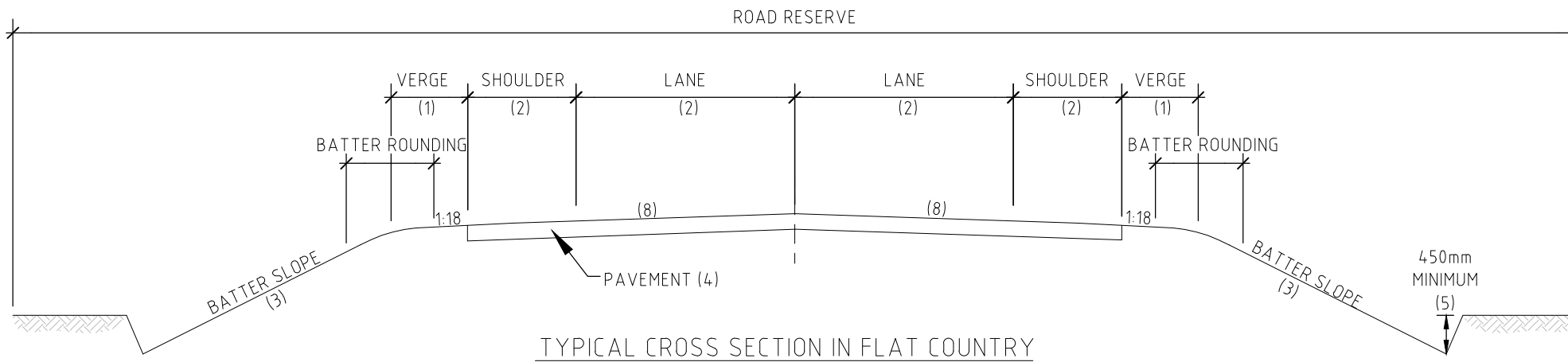

TYPICAL CROSS SECTION IN FLAT COUNTRY

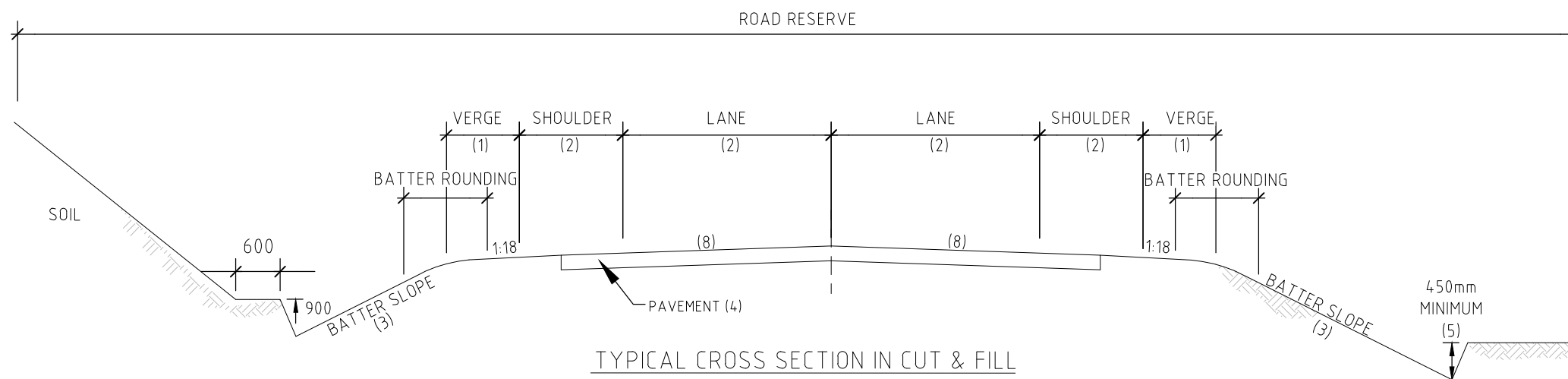

TYPICAL CROSS SECTION IN CUT & FILL

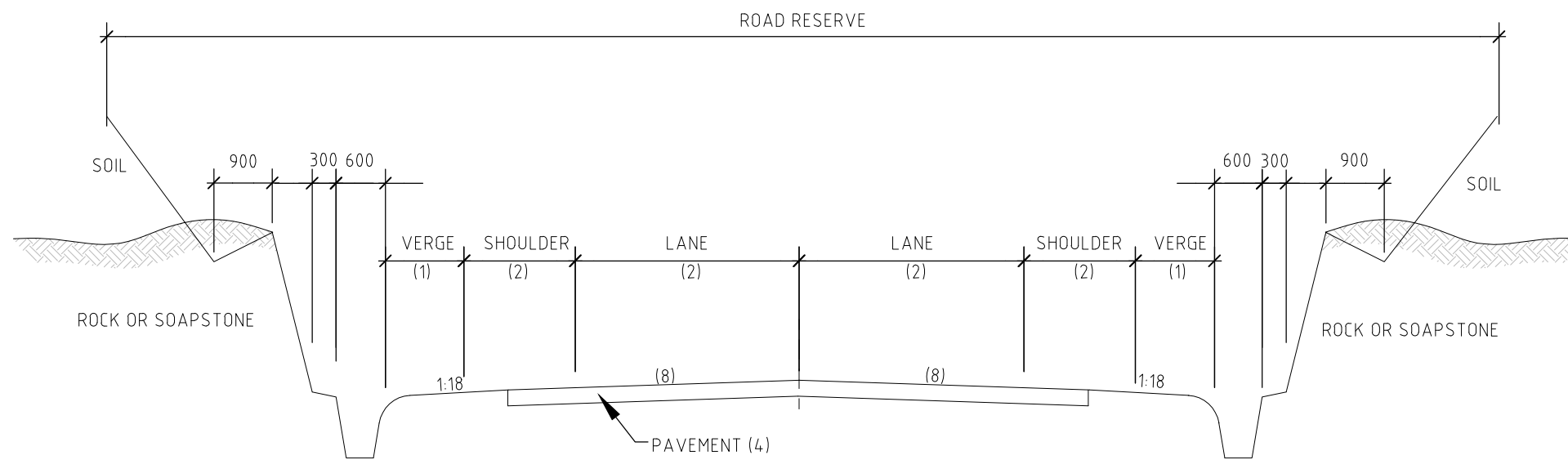

TYPICAL CROSS SECTION IN ROCK

**NOTES:**

1. REFER AGRD PART3 SECTION 4.4.1 for VERGE WIDTH.
2. REFER FRA SUPPLEMENT TABLE V4.2 FOR SHOULDER WIDTH.
3. REFER AGRD PART 3 SECTION 4.6 AND FRA SUPPLEMENT CH 3 SECTION 4.5 FOR BATTER SLOPE.
4. PAVEMENT DESIGN AS PER FRA PAVEMENT DESIGN SUPPLEMENT.
5. INVERT SHALL BE A MINIMUM OF 150mm BELOW SUBGRADE
6. DRAINAGE DIMENSIONS ARE MINIMUM ONLY. REFER TO AGRD 5(b), SECTION 2.13 FOR DRAINAGE DESIGN.
7. REFER TO STANDARD DRAWING NUMBER R502-1 TO 3. FOR SUBSURFACE DRAINAGE DETAILS.
8. REFER AGRD, PART 3 SECTION 4.2.2 AND FRA SUPPLEMENT CH 3, SECTION 4.2.2 FOR PAVEMENT SCOPE
9. THESE DRAWINGS SHOW CROSS SECTION GEOMETRIC DETAILS ONLY. FOR DRAINAGE OF PAVEMENT LAYERS REFER TO ALTERNATIVE DETAILS AND DESIGN GUIDES

PLOT DATE 12/03/2019

150  
100  
50  
40  
30  
20  
10

A3 ORIGINAL SIZE	E				
	D				
	C				
	B				
	A				
ISSUE	APPD	DATE	AMENDMENT	BY	GENERAL NOTES

GENERAL NOTES

**STANDARD DRAWINGS  
TYPICAL ROAD CROSS SECTION  
UNSEALED MAIN ROADS**

SCALE	DATE 30 MAR 17	DESIGN BY
-------	-------------------	-----------

DRAWN BY CWS	APPROVED	DRAWING No. R 306	SHEET No. 01	ISSUE A
-----------------	----------	----------------------	-----------------	------------

## TYPICAL CROSS SECTION UNSEALED SECONDARY AND COUNTRY ROADS

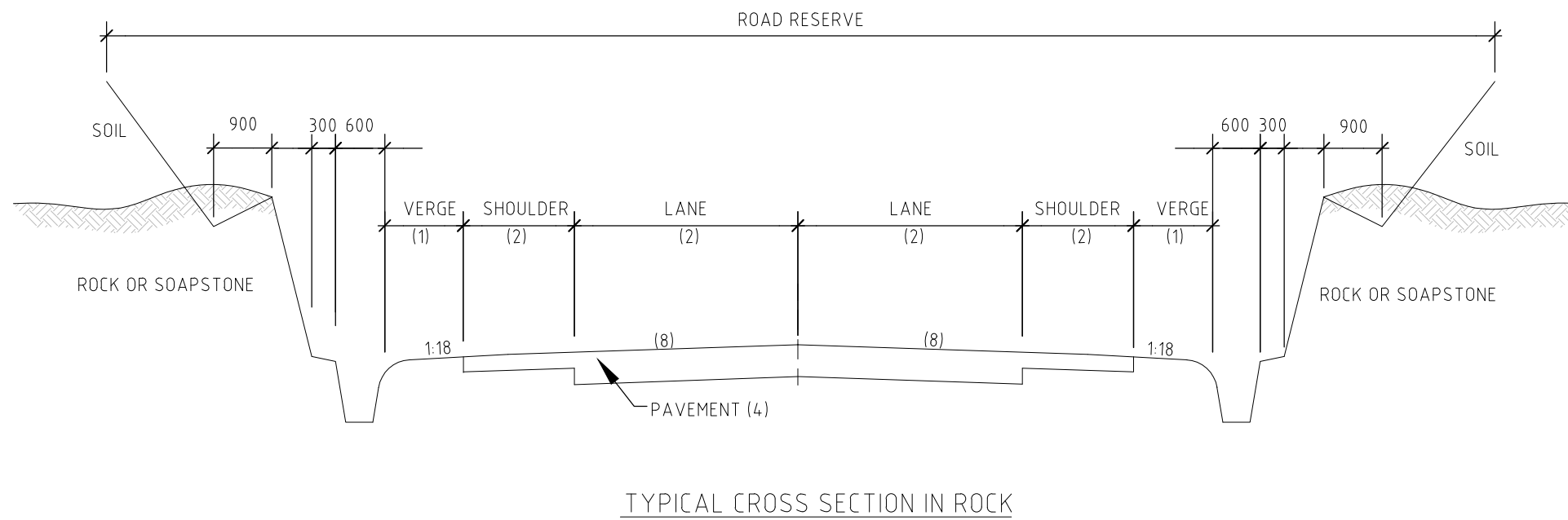
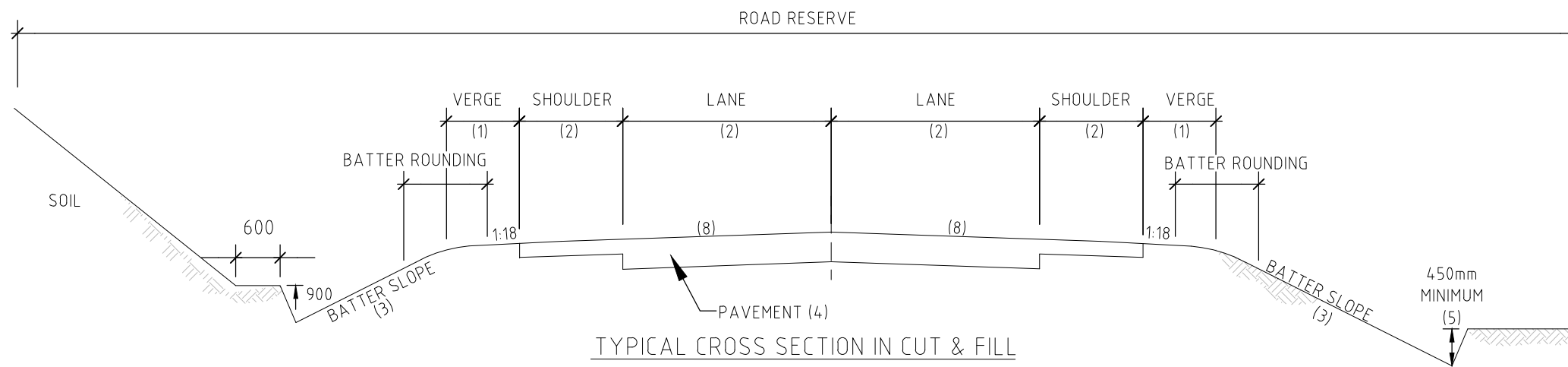
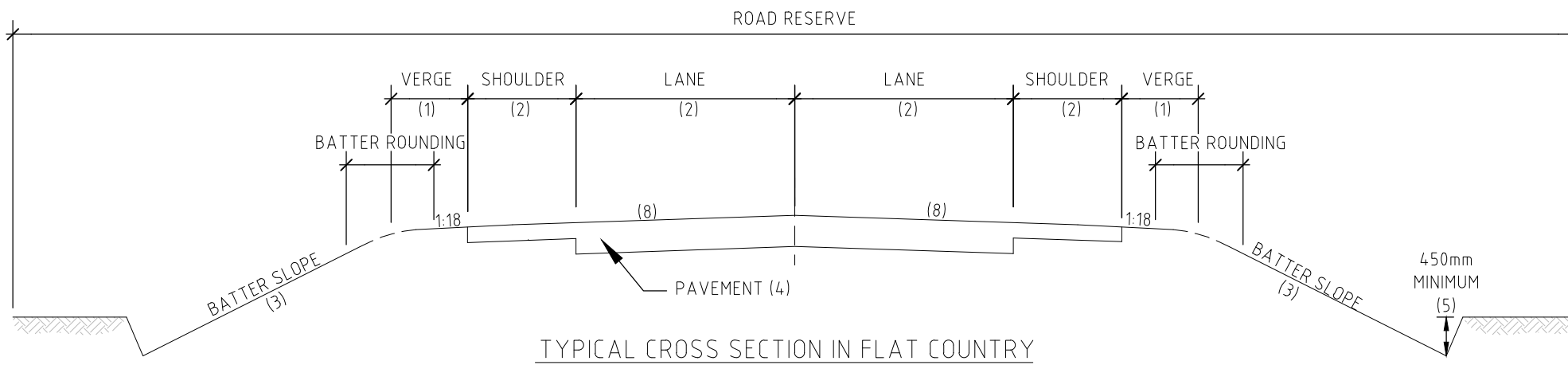

### NOTES:

1. REFER AGRD PART3 SECTION 4.4.1 for VERGE WIDTH.
2. REFER FRA SUPPLEMENT TABLE V4.2 FOR SHOULDER WIDTH.
3. REFER AGRD PART 3 SECTION 4.6 AND FRA SUPPLEMENT CH 3 SECTION 4.5 FOR BATTER SLOPE.
4. PAVEMENT DESIGN AS PER FRA PAVEMENT DESIGN SUPPLEMENT.
5. INVERT SHALL BE A MINIMUM ONLY. REFER TO A BELOW SUBGRADE LEVEL.
6. DRAINAGE DIMENSIONS ARE MINIMUM ONLY. REFER TO AGRD 5(b), SECTION 2.13 FOR DRAINAGE DESIGN.
7. REFER TO STANDARD DRAWING NUMBER R502-1 TO 3. FOR SUBSURFACE DRAINAGE DETAILS.
8. REFER AGRD, PART 3 SECTION 4.2.2 AND FRA SUPPLEMENT CH 3, SECTION 4.2.2 FOR PAVEMENT SCOPE
9. THESE DRAWINGS SHOW CROSS SECTION GEOMETRIC DETAILS ONLY. FOR DRAINAGE OF PAVEMENT LAYERS REFER TO ALTERNATIVE DETAILS AND DESIGN GUIDES

PLOT DATE 12/03/2019

150  
100  
50  
40  
30  
20  
10

ISSUE	APP'D	DATE	AMENDMENT	BY
E				
D				
C				
B				
A				

GENERAL NOTES

**STANDARD DRAWINGS**

**TYPICAL CROSS SECTION  
UNSEALED SECONDARY & COUNTRY ROADS**

SCALE	DATE	DESIGN BY
	30 MAR 17	

DRAWN BY CWS	APPROVED	DRAWING No. R 307	SHEET No. 01	ISSUE A
-----------------	----------	----------------------	-----------------	------------

# TYPICAL CROSS SECTION

## UNSEALED SECONDARY, COUNTRY AND RESIDENTIAL SINGLE LANE ROADS CROSS SECTION

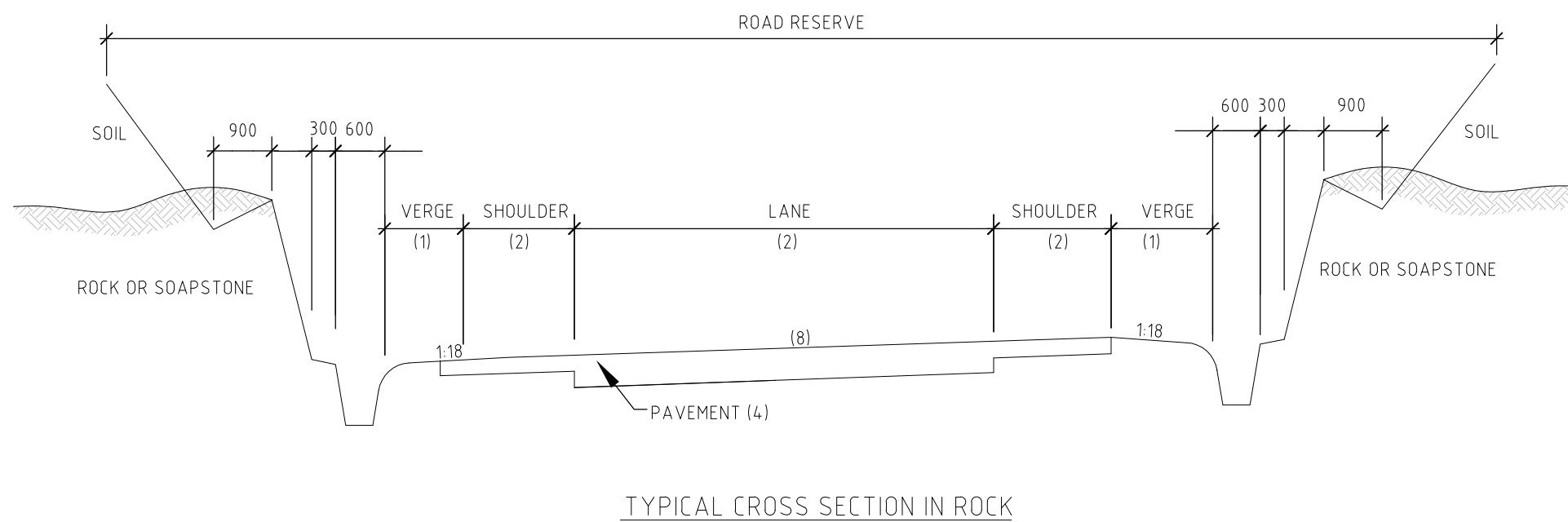
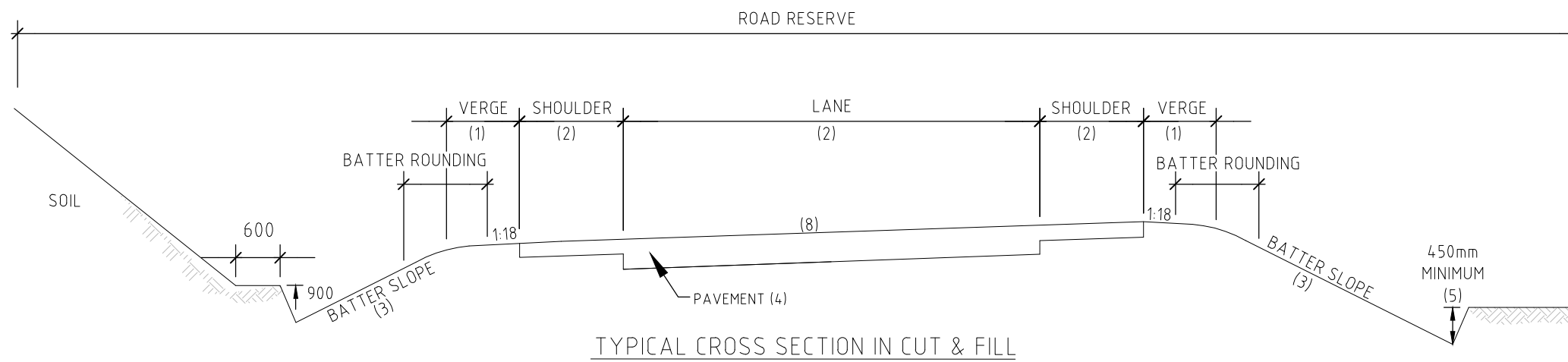
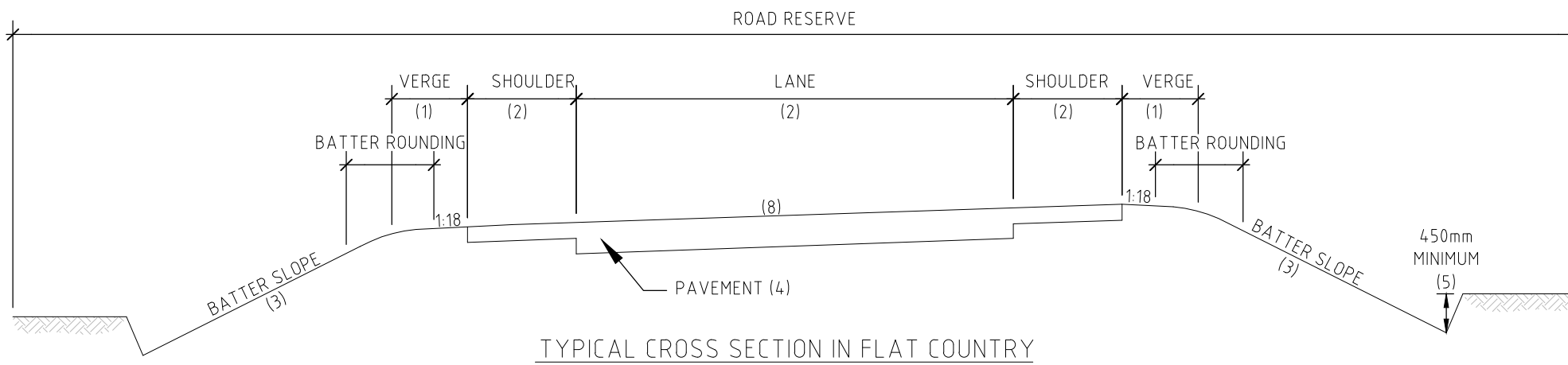

### NOTES:

1. REFER AGRD PART3 SECTION 4.4.1 for VERGE WIDTH.
2. REFER FRA SUPPLEMENT TABLE V4.2 FOR SHOULDER WIDTH.
3. REFER AGRD PART 3 SECTION 4.6 AND FRA SUPPLEMENT CH 3 SECTION 4.5 FOR BATTER SLOPE.
4. PAVEMENT DESIGN AS PER FRA PAVEMENT DESIGN SUPPLEMENT.
5. INVERT SHALL BE A MINIMUM ONLY. REFER TO A BELOW SUBGRADE LEVEL.
6. DRAINAGE DIMENSIONS ARE MINIMUM ONLY. REFER TO AGRD 5(b), SECTION 2.13 FOR DRAINAGE DESIGN.
7. REFER TO STANDARD DRAWING NUMBER R502-1 TO 3. FOR SUBSURFACE DRAINAGE DETAILS.
8. REFER AGRD, PART 3 SECTION 4.2.2 AND FRA SUPPLEMENT CH 3, SECTION 4.2.2 FOR PAVEMENT SCOPE
9. FRA CURRENT POLICY IS TO NOT CONSTRUCT SINGLE LANE ROADS, HOWEVER, THIS TYPICAL CROSS SECTION IS PROVIDED AS AN APPROPRIATE STANDARD FOR SINGLE LANE ROADS IN FIJI
10. THESE DRAWINGS SHOW CROSS SECTION GEOMETRIC DETAILS ONLY. FOR DRAINAGE OF PAVEMENT LAYERS REFER TO ALTERNATIVE DETAILS AND DESIGN GUIDES

PLOT DATE 12/03/2019

150  
100  
50  
40  
30  
20  
10

A3 ORIGINAL SIZE	E				
	D				
	C				
	B				
	A				
ISSUE	APPD	DATE	AMENDMENT	BY	GENERAL NOTES

GENERAL NOTES

<b>STANDARD DRAWINGS</b>		
TYPICAL CROSS SECTION UNSEALED SECONDARY, COUNTRY AND RESIDENTIAL ROADS CROSS SECTION		
SCALE	DATE	DESIGN BY
	30 MAR 17	

Fiji Roads Authority

DRAWN BY	APPROVED	DRAWING No.	SHEET No.	ISSUE
CWS		R 308	01	A

PLOT DATE 12/03/2019

150  
100  
50  
40  
30  
20  
10

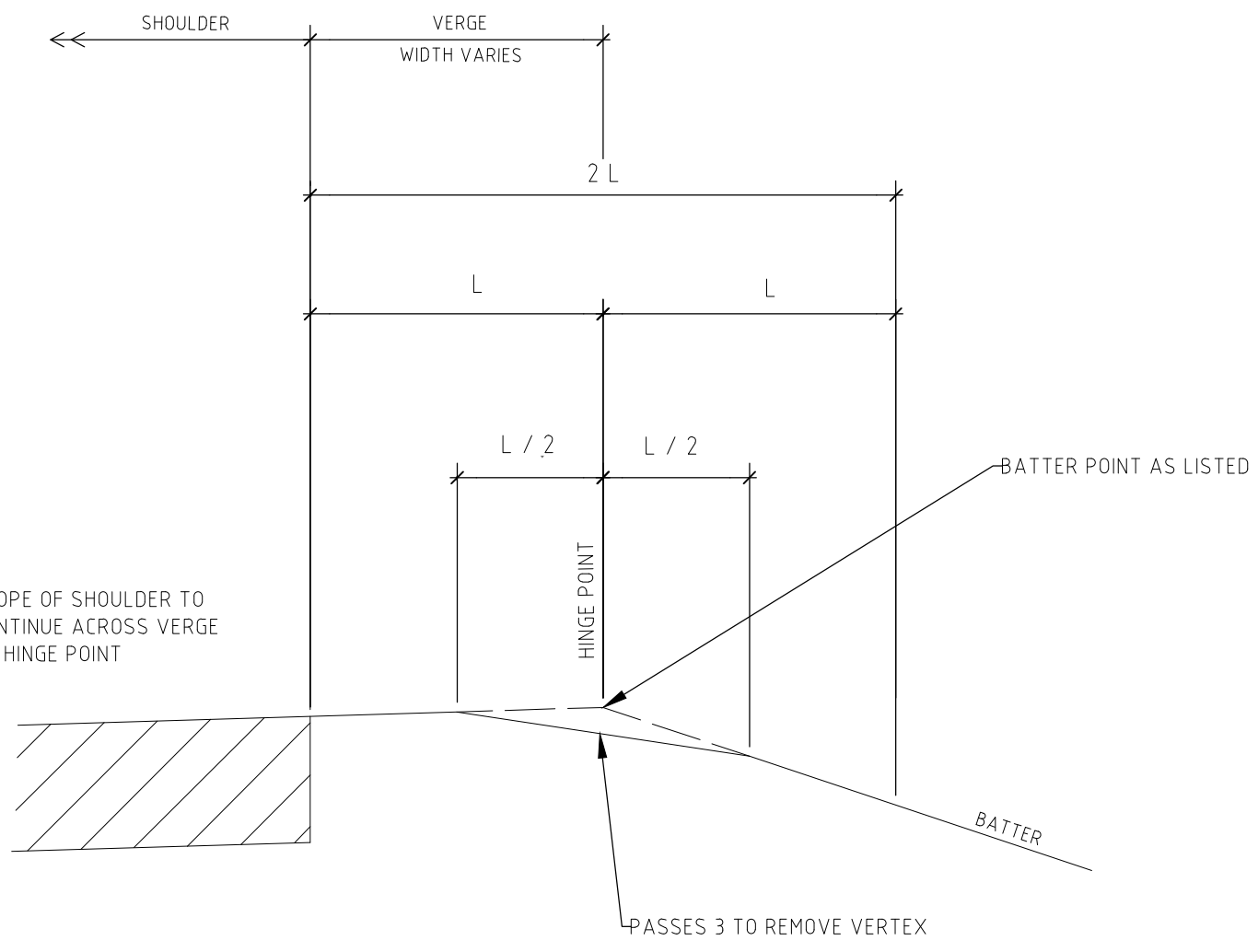

BATTER EQUAL TO OR LESS THAN 3:1  
ONE PASS OF A GRADER BLADE TO  
FLATTEN THE VERTEX OF THE TWO  
SURFACES.

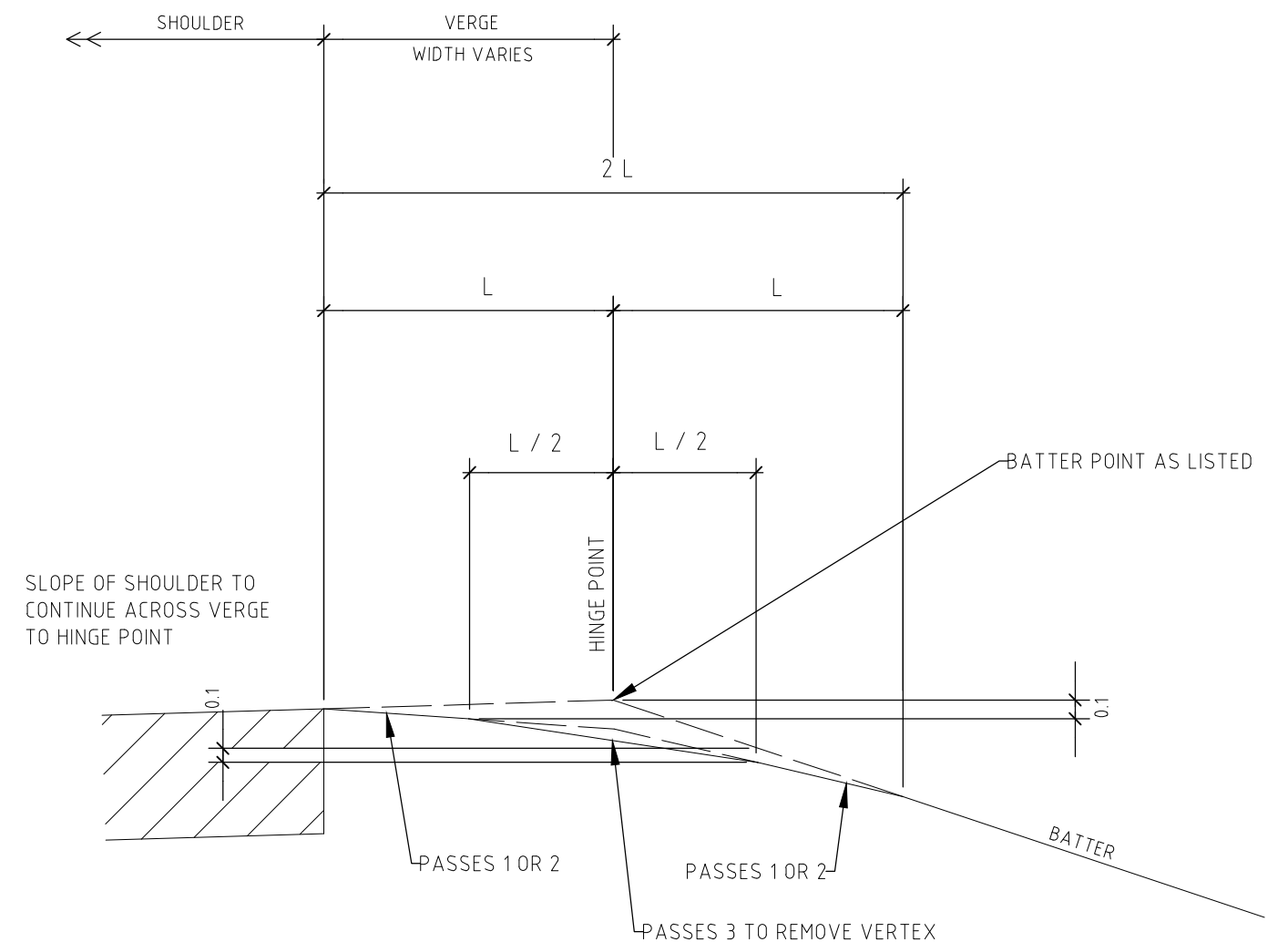

BATTER EQUAL TO OR GREATER  
THAN 3:1 THREE PASSES OF A  
GRADER BLADE TO FLATTEN THE  
VERTEX OF THE TWO SURFACES.

- NOTES:**
1. THE MINIMUM VERGE WIDTHS, L, ARE SHOWN IN TABLE 3.6.4.2 OF PDG PART 3. FOR THE CHANGE IN LATERAL GRADE BETWEEN THE SHOULDER AND THE FILL BATTER.
  2. THESE DRAWINGS SHOW CROSS SECTION GEOMETRIC DETAILS ONLY. FOR DRAINAGE OF PAVEMENT LAYERS REFER TO ALTERNATIVE DETAILS AND DESIGN GUIDES

A3 ORIGINAL SIZE

E				
D				
C				
B				
A				
ISSUE	APPD	DATE	AMENDMENT	BY

**GENERAL NOTES**

1. DIMENSIONS ARE IN MILLIMETERS UNLESS SHOWN OTHERWISE.
2. VERGE ROUNDING NOT REQUIRED - (1) IN CUT (2) BEHIND K&C IN CUT OR FILL (3) BEHIND SAFETY BARRIERS
3. BATTERS SHALL BE ROUNDED PRIOR TO TOPSOILING.
4. THESE DRAWINGS SHOW CROSS SECTION GEOMETRIC DETAILS ONLY. FOR DRAINAGE OF PAVEMENT REFER TO RELATIVE DETAILS AND DESIGN GUIDES

<b>STANDARD DRAWINGS</b>			
<b>CONSTRUCTION OF VERGE ROUNDING</b>			
SCALE	DATE	DESIGN BY	DRAWN BY
	30 MAR 17		CWS

Fiji Roads Authority

DRAWING No. R 309	SHEET No. 01	ISSUE A	
----------------------	-----------------	------------	--

# TYPICAL CROSS SECTION URBAN ARTERIAL ROADS

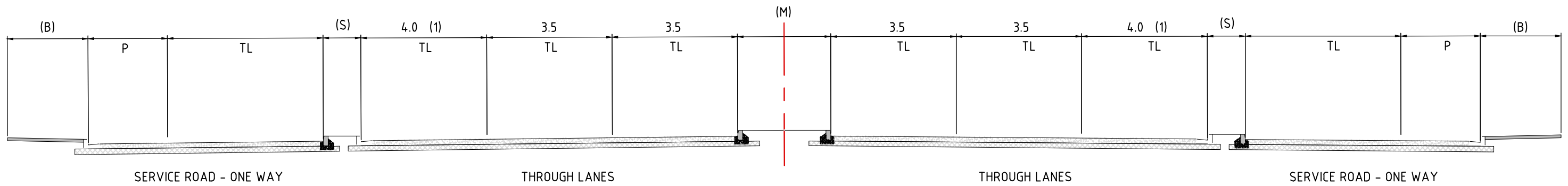
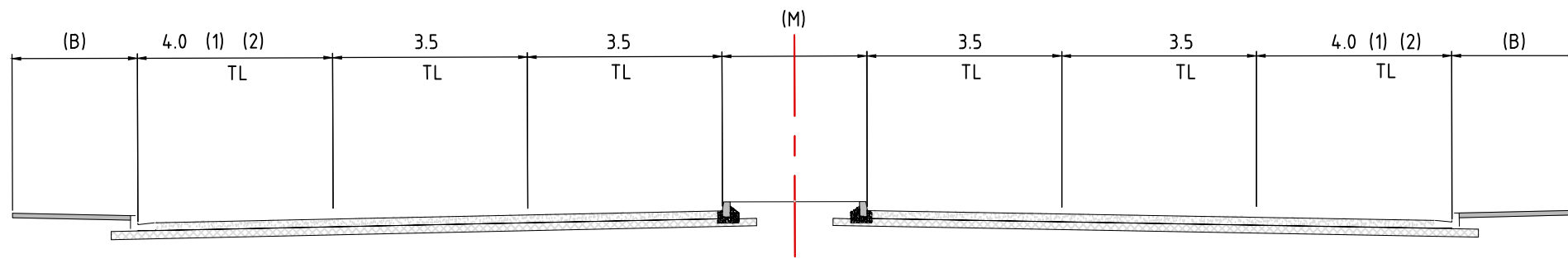
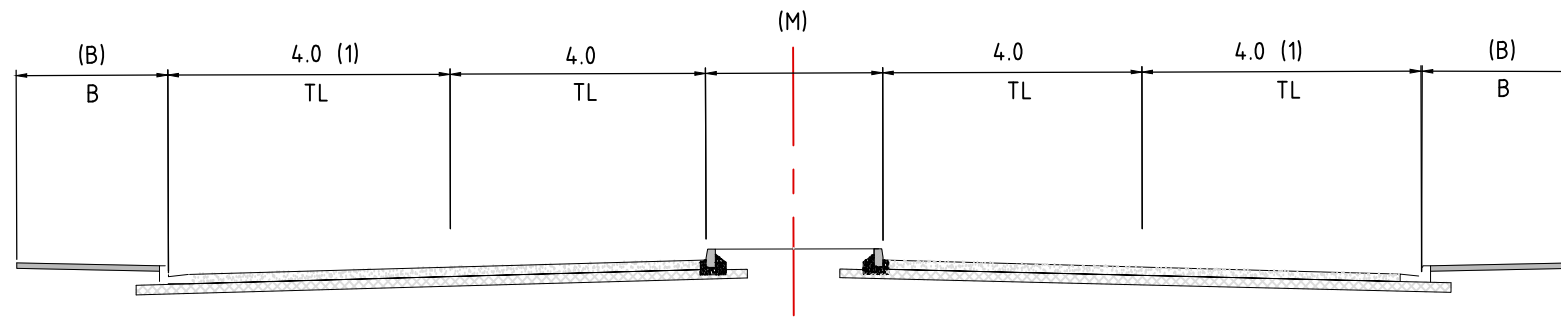

**NOTES:**

- (B) Border - 7.3m to the line desirable if trunk utility services are provided, 4.3m minimum.
- (M) Median - 6.0m line to line desirable minimum for protection of turning vehicles & pedestrians.
- (S) Outer Separator - 2.4m line to line desirable minimum. Increase to 5.4m for indented bus bays.
- (P) Parking
- (TL) Traffic Lane

1. Left Lane Width may be increased -
  - 4.5m to line for bicycle and cars
  - 4.0m to line for buses or more than 200 trucks/hr
2. Parking may be permitted in off peak hours periods.
3. Refer also to AGRD Table 4.3 for minimum widths
4. Refer to Drawing No R 502 1-3 for SSD Details.
5. These drawings show cross section geometric details only. For drainage of pavement layers refer to alternative details and design guides
6. Refer to FRA for mor information on minimum road and carriageway widths for new housing developments

PLOT DATE 12/03/2019

150  
100  
50  
40  
30  
20  
10

A3 ORIGINAL SIZE	E				
	D				
	C				
	B				
	A				
ISSUE	APPD	DATE	AMENDMENT	BY	

GENERAL NOTES
---------------

STANDARD DRAWINGS		
TYPICAL CROSS SECTION URBAN ARTERIAL ROAD.		
SCALE	DATE	DESIGN BY
	30 MAR 17	

**Fiji Roads Authority**

DRAWN BY	APPROVED	DRAWING No.	SHEET No.	ISSUE
CWS		R 310	01	A

PLOT DATE 12/03/2019

TYPICAL URBAN COLLECTOR AND LOCAL ROADS

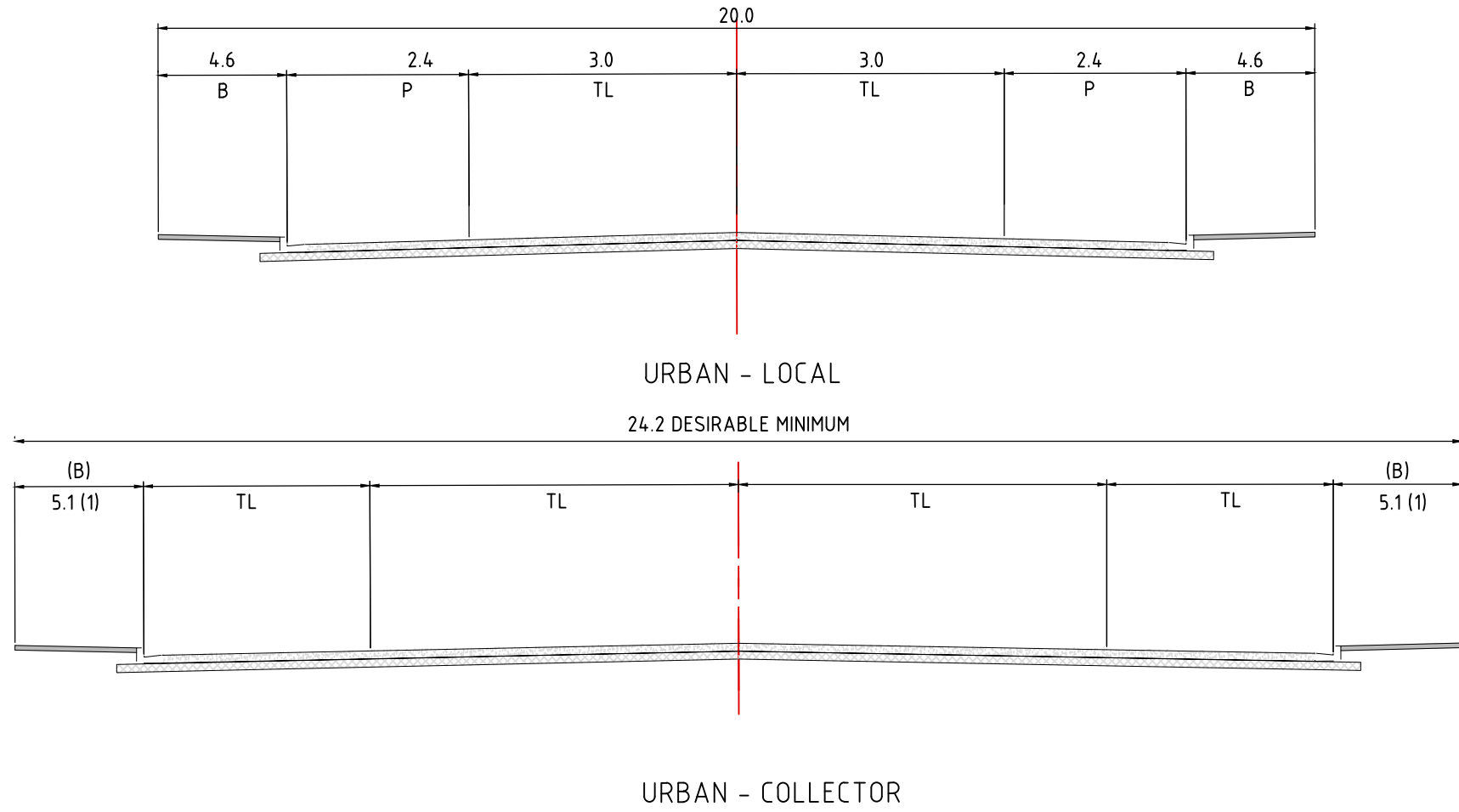

NOTES:

- (B) Border - 7.3m to the line desirable if trunk utility services are provided, 4.3m minimum.
- (P) Parking
- (TL) Traffic Lane
- 1. Governed by allocation of services, assuming no joint use of trenches.
- 2. Refer also AGRD, Table 4.3 for minimum widths
- 3. Refer Drawing No. R502 1-3 for SSD Details.
- 4. These drawings show cross section geometric details only. For drainage of pavement layers refer to alternative details and design guides
- 5. Refer to FRA for mor information on minimum road and carriageway widths for new housing developments

A3 ORIGINAL SIZE

E					
D					
C					
B					
A					
ISSUE	APPD	DATE	AMENDMENT	BY	GENERAL NOTES

STANDARD DRAWINGS		
TYPICAL CROSS SECTION URBAN, COLLECTOR AND LOCAL ROAD.		
SCALE	DATE	DESIGN BY
NTS	30 MAR 17	

**Fiji Roads Authority**

DRAWN BY	APPROVED	DRAWING No.	SHEET No.	ISSUE
CWS		R 311	01	A

PLOT DATE 18/10/2018

150

100

50

40

30

20

10

A3 ORIGINAL SIZE

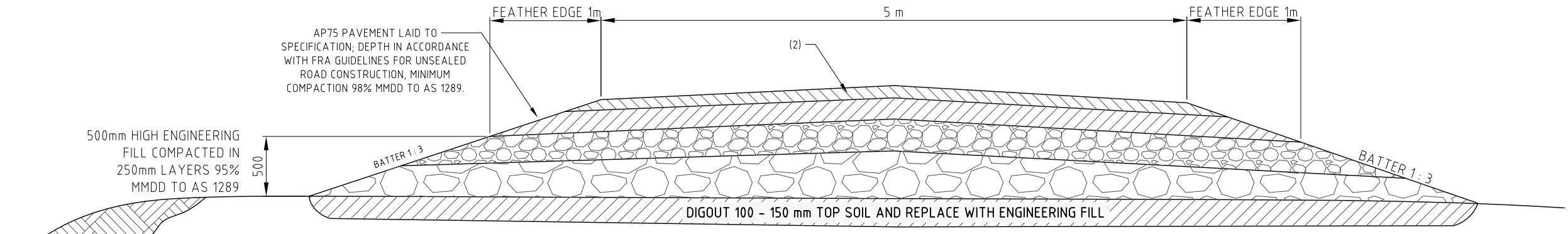

TYPICAL CROSS SECTION 'C'  
SCALE 1 : 20

**NOTES:**

1. For d50 refer to AGRD Supplement, 5(b) Section 2.9.2.
2. Refer to Pavement Design Guide Supplement for Pavement Design

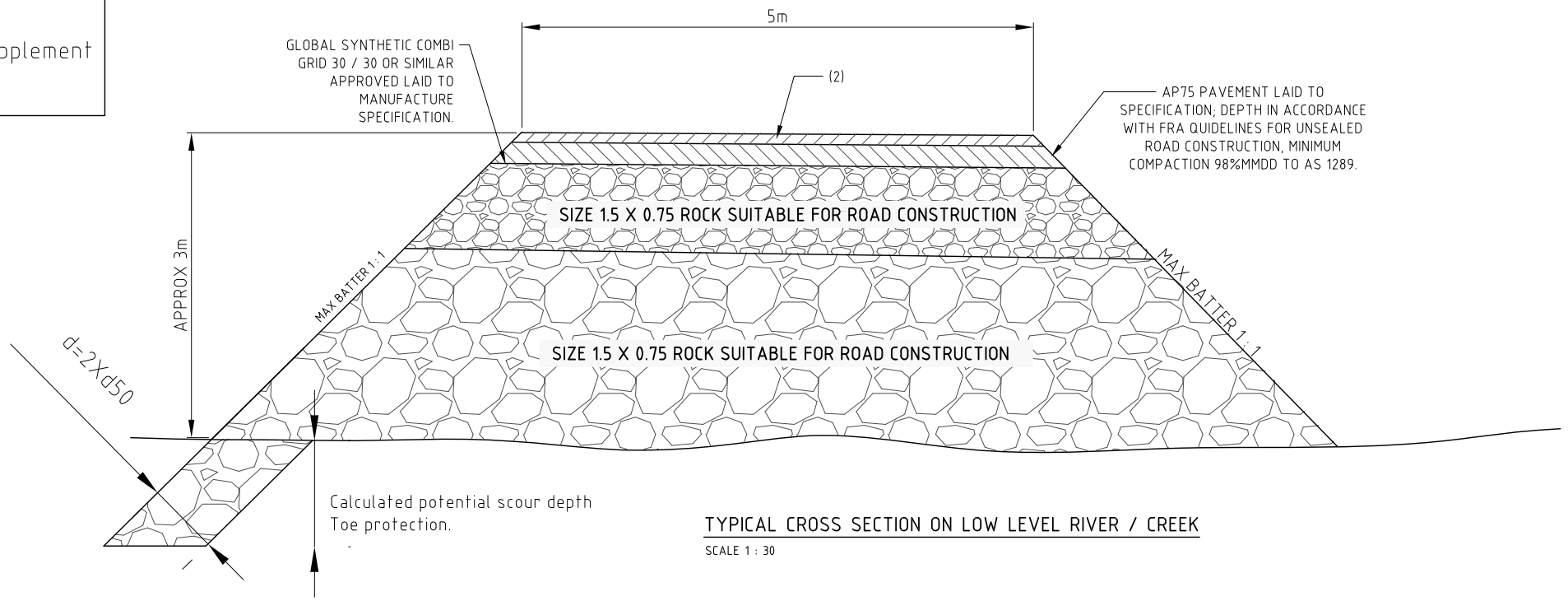

TYPICAL CROSS SECTION ON LOW LEVEL RIVER / CREEK  
SCALE 1 : 30

E					
D					
C					
B					
A					
ISSUE	APPD	DATE	AMENDMENT	BY	

GENERAL NOTES

**STANDARD DRAWINGS**

**TYPICAL RURAL ROAD CROSS SECTION  
LOW LEVEL RIVER / CREEK.**

SCALE	AS SHOWN	DATE	05 April 17	DESIGN BY	
-------	----------	------	-------------	-----------	--

DRAWN BY	CWS	APPROVED		DRAWING No.	R 312	SHEET No.	01	ISSUE	
----------	-----	----------	--	-------------	-------	-----------	----	-------	--

PLOT DATE 18/10/2018

150

100

50

40

30

20

10

A3 ORIGINAL SIZE

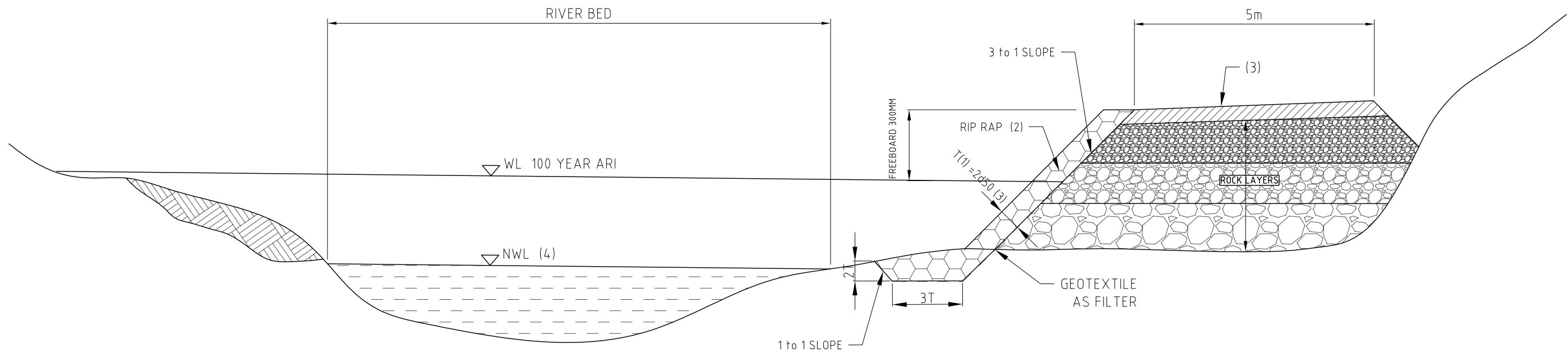

TYPICAL CROSS LOW LEVEL RIVER CREEK.  
SCALE 1 : 50

NOTES:

1. Minimum two layers of rock.
2. For the calculation of d50 refer to supplements part 5B, Section 2.9.2
3. Refer pavement design guide supplement for pavement design.
4. NWL - Normal Water Level.

E				
D				
C				
B				
A				
ISSUE	APPD	DATE	AMENDMENT	BY

GENERAL NOTES

STANDARD DRAWINGS	
TYPICAL CROSS SECTION LOW LEVEL RIVER / CREEK.	
SCALE	DATE
	05 April 17
DESIGN BY	

		DRAWING No.	SHEET No.	ISSUE
		R 313	01	
DRAWN BY	APPROVED			
CWS				

# INDEX SHEET

## SECTION 501 UNDERGROUND STORM WATER DRAINAGE

DRAWING NUMBER	DRAWING TITLE
R 501 - 1	INLET & OUTLET, WINGWALL & HEADWALL DETAIL.
R 501 - 2	STANDARD OUTFALL DETAILS
R 501 - 3	STANDARD OUTFALL DETAILS – ADDITIONAL EROSION PROTECTION DETAIL
R 501 - 4	INLET / OUTLET RIPRAP DETAIL
R 501 - 5	STANDARD HEADWALL DETAIL
R 501 - 6	STANDARD HEADWALL DETAIL – ADDITIONAL EROSION PROTECTION DETAIL
R 501 - 7	STACKED STONE HEADWALL
R 501 - 8	STACKED STONE HEADWALL– ADDITIONAL EROSION PROTECTION DETAIL
R 501 - 9	DRIVEABLE HEADWALL DETAIL TYPE 1
R 501 - 10	DRIVEABLE HEADWALL DETAIL TYPE 2
R 501 - 11	EFFECTS OF TRAFFIC LOADS ON CONCRETE PIPES
R 501 - 12	PERMISSIBLE DEPTHS OF FILLING OVER RC PIPES EMBANKMENT CONDITION
R 501 - 13	PERMISSIBLE DEPTHS OF FILLING OVER RC PIPES IN TRENCH CONDITION
R 501 - 14	CONCRETE PIPES UNDER EMBANKMENT ON EARTH
R 501 - 15	CONCRETE PIPES UNDER EMBANKMENT ON EARTH & ROCK
R 501 - 16	CONCRETE PIPES IN TRENCH TYPES OF BEDDING ON EARTH
R 501 - 17	PIPES TRENCHES STANDARD DETAILS

PLOT DATE 18/10/2018

150  
100  
50  
40  
30  
20  
10

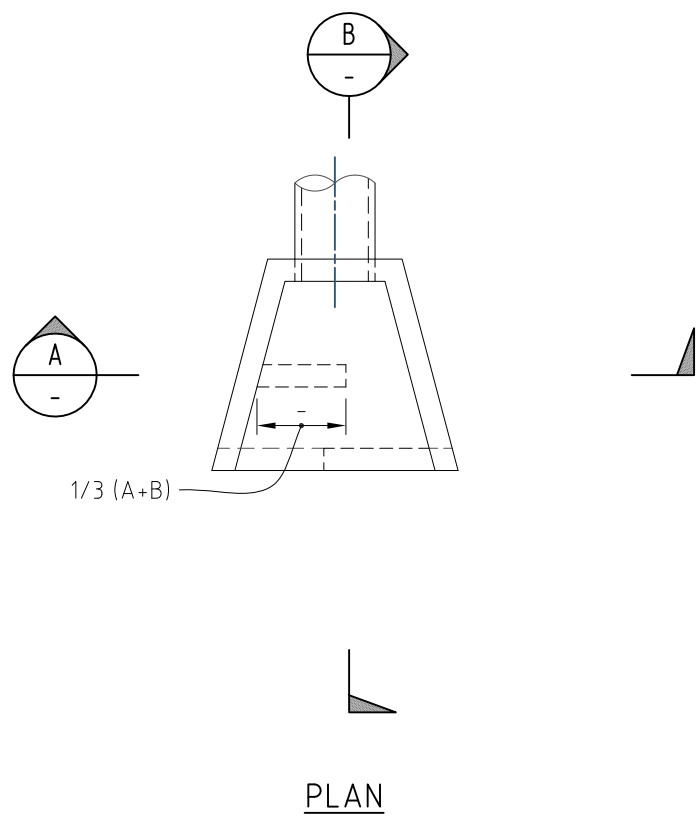
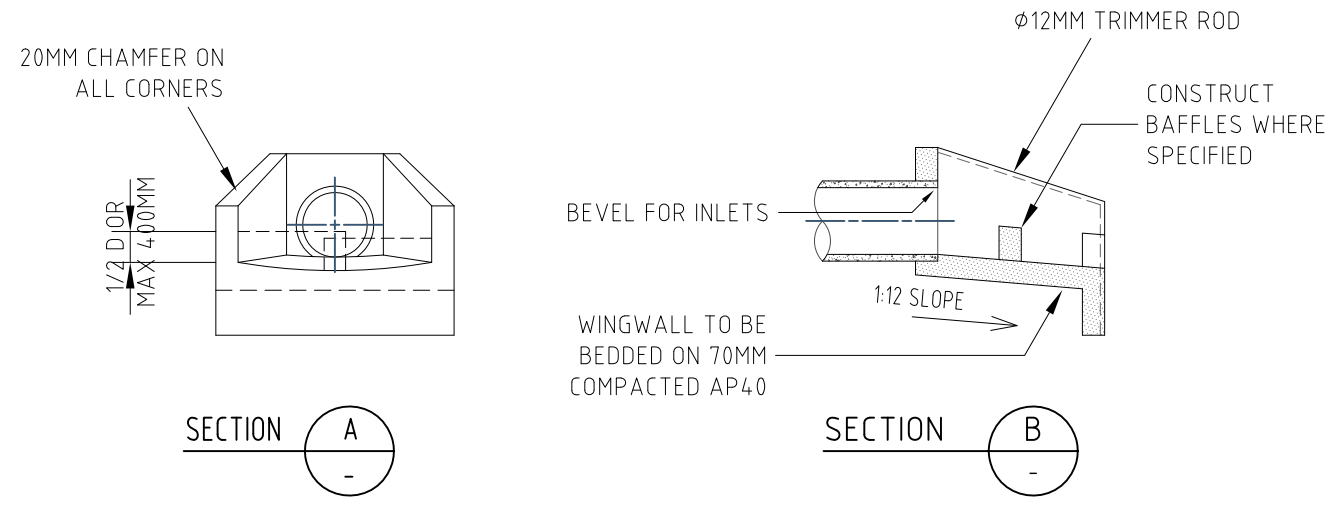

**NOTES:**

1. FOR SUB-SOIL DRAIN DETAIL REFER TO DRG. No. R502 1-3.
2. ALL DIMENSIONS SHOWN IN MILLIMETERS UNLESS OTHERWISE SHOWN.
3. GROUND CONDITIONS WILL REQUIRE / DETERMINE THE SUITABILITY OF USING UN-LINED / UN-REINFORCEABLE DRAIN. THE SUITABILITY OF A DRAIN TYPE WILL BE DETERMINED BY THE ENGINEER ON SITE. WHEN THE GROUND CONDITIONS CAN BE ACCURATELY ASSESSED. HOWEVER THE FOLLOWING SHALL APPLY IN GENERAL:
  - a. AN OPEN DRAIN WITH A BACK SLOPE 1V : 1H SHALL BE LIMITED TO 1M DRAIN DEPTH FROM TOP OF BANK TO DRAIN INVERT / BONE / BONE LEVEL.
  - b. DRAINS EXCEEDING 1M DEPTH BUT NOT EXCEEDING 1.5M SHALL HAVE ADDITIONAL SIDE SUPPORT EITHER USING A STONE FACE LINING CEMENTED IN PLACE AS PER TYPICAL DRAIN DETAIL C OR ANOTHER SUITABLE ENGINEERING SOLUTION AGREED ON SITE BY THE ENGINEER.
  - c. GENERALLY DRAINS SHALL NOT BE CONSTRUCTED EXCEEDING 1.5M DEPTH WHILST ADDITIONAL MEASURES DEPLOYED TO MITIGATE AGAINST THE RISK OF COLLAPSING SIDES. SUCH MEASURES MAY REQUIRE CONSTRUCTION OF CONCRETE CHANNEL SECTIONS IN DRAIN BOTTOM / INVERT TO REDUCE THE EFFECTIVE SOIL BANK HEIGHT.
  - d. CONCRETE COVER TO REINFORCING BARS TO BE 40MM MINIMUM IN ALL CASES.
  - e. FOR NUMBER, POSITION, AND DIMENSIONS OF CONCRETE BAFFLES, REFER TO SUPPLEMENTS PART 5B, SECTION 3.7.1
  - f. FOR SCOUR PROTECTION REFER DRAWINGS No 501-2
  - g. FOR FURTHER DIMENSIONS REFER R 501-3.

A3 ORIGINAL SIZE	E				
	D				
	C				
	B				
	A				
ISSUE	APPD	DATE	AMENDMENT	BY	

GENERAL NOTES

<b>STANDARD DRAWINGS</b>		
<b>INLET / OUTLET WINGWALL &amp; HEADWALL DETAILS</b>		
SCALE	DATE	DESIGN BY
	05 April 17	

**Fiji Roads Authority**

DRAWN BY	APPROVED	DRAWING No.	SHEET No.	ISSUE
CWS		R 501-1	01	

PLOT DATE 05/02/2020

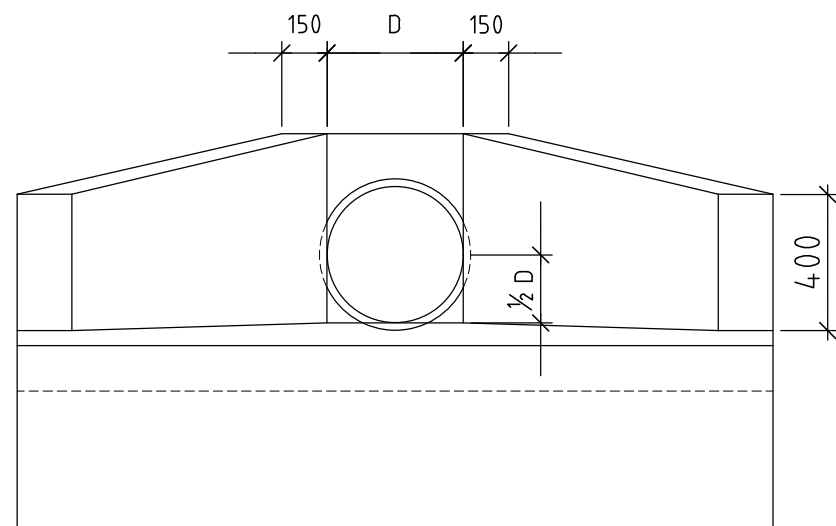
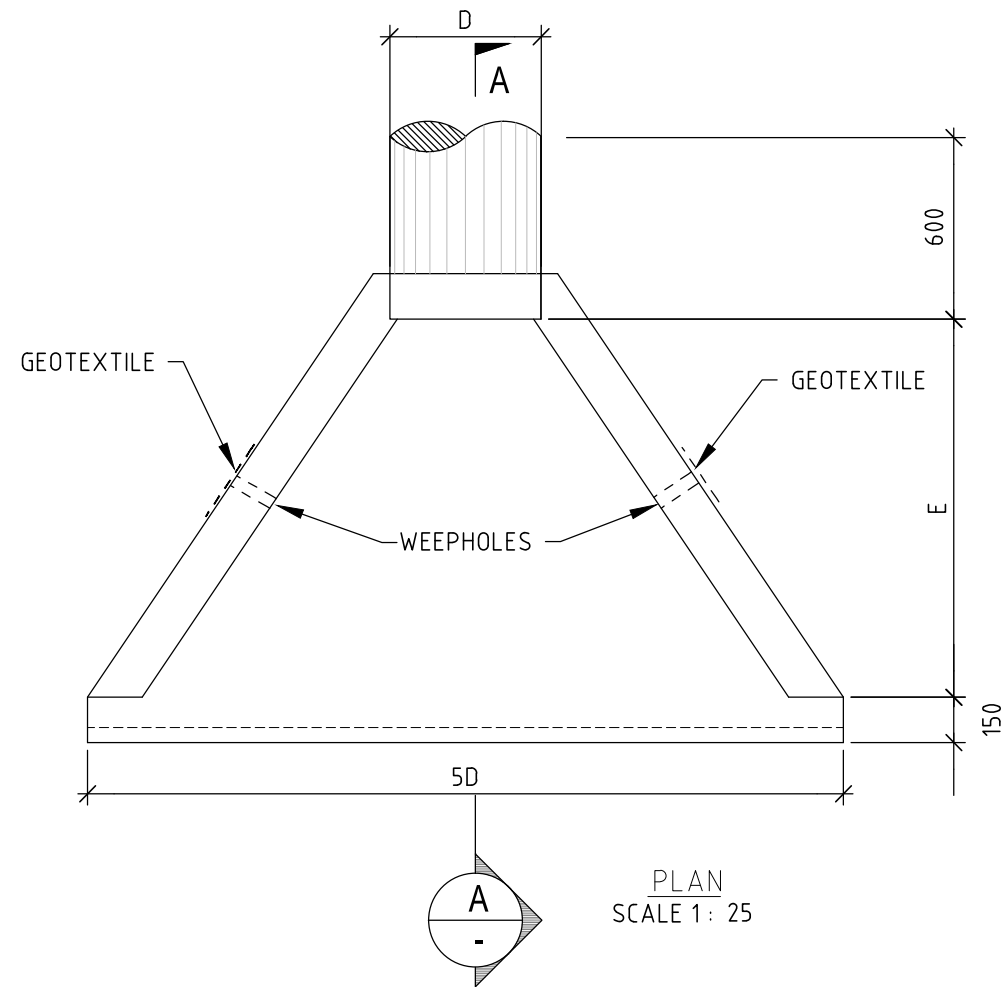

**NOTES**

1. DIMENSION MAY BE VARIED ACCORDING TO ENGINEER'S DIRECTIONS.
2. CONCRETE STRENGTH TO BE 25MPa AT 28DAYS.
3. REINFORCEMENT HEADWALLS AND APRON SLAB WITH 10mm  $\phi$  BARS BOTHWAYS OR AS DIRECTED BY ENGINEER.
4. FOR ADDITIONAL SCOUR PROTECTION DETAILS REFER R501-15
5. WEEPHOLES OF 75mm PVC @1200 SPACINGS WITH 200X200 GEOTEXTILE FILTER.
6. FRA APPROVAL SHALL BE SOUGHT FOR ALTERNATIVE PRECAST UNITS

PIPE DIA	A	B	C	E
450	150	450	150	600
600	200	600	150	800
900	200	900	230	1620
1200	250	900	250	2400
1500	250	900	250	2400

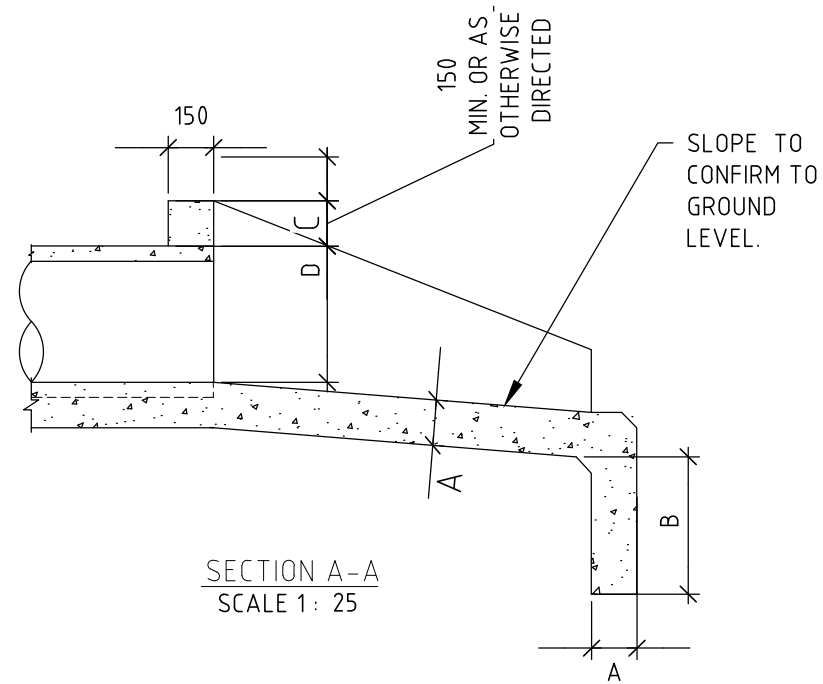

A3 ORIGINAL SIZE	E	D	C	B	A
ISSUE	APPD	DATE	AMENDMENT		BY
		5/02/2020	INCLUSION OF 450 DIAMETER CULVERT SIZE		A.K

GENERAL NOTES

STANDARD DRAWINGS		
STANDARD OUTFALL DETAIL		
SCALE	DATE	DESIGN BY
AS SHOWN	05 FEB 2020	

**Fiji Roads Authority**

DRAWN BY	APPROVED	DRAWING No.	SHEET No.	ISSUE
	A KETENILAGI	R 501 - 2	01	A

PLOT DATE 20/03/2019

150  
100  
50  
40  
30  
20  
10

A3 ORIGINAL SIZE

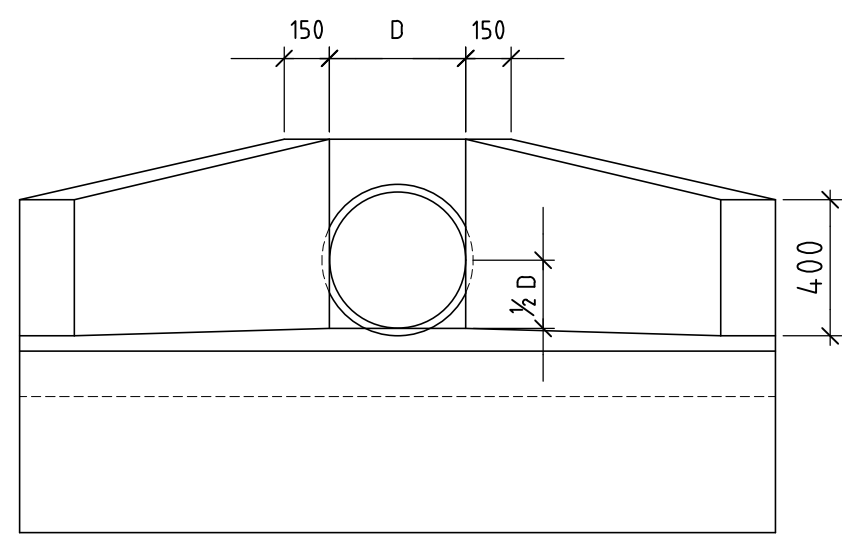
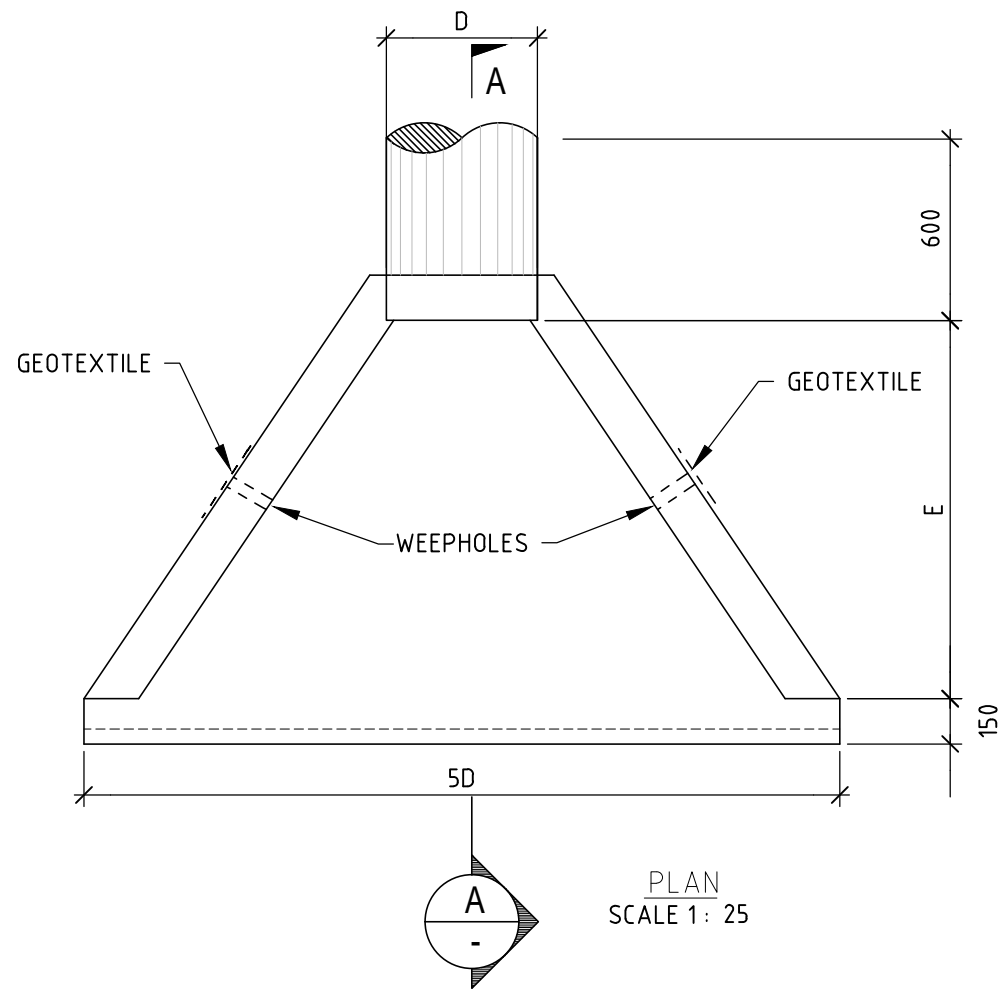

**NOTES**

1. DIMENSION MAY BE VARIED ACCORDING TO ENGINEER'S DIRECTIONS.
2. CONCRETE STRENGTH TO BE 25MPa AT 28DAYS.
3. REINFORCEMENT HEADWALLS AND APRON SLAB WITH 10mm  $\phi$  BARS BOTHWAYS OR AS DIRECTED BY ENGINEER.
4. FOR dr AND d50 REFER TO AGRD PART 5 SECTION 3.13.
5. FRA APPROVAL SHALL BE SOUGHT FOR ALTERNATIVE PRECAST UNITS

PIPE DIA	A	B	C	E
600	200	600	150	800
900	200	900	230	1620
1200	250	900	250	2400
1500	250	900	250	2400

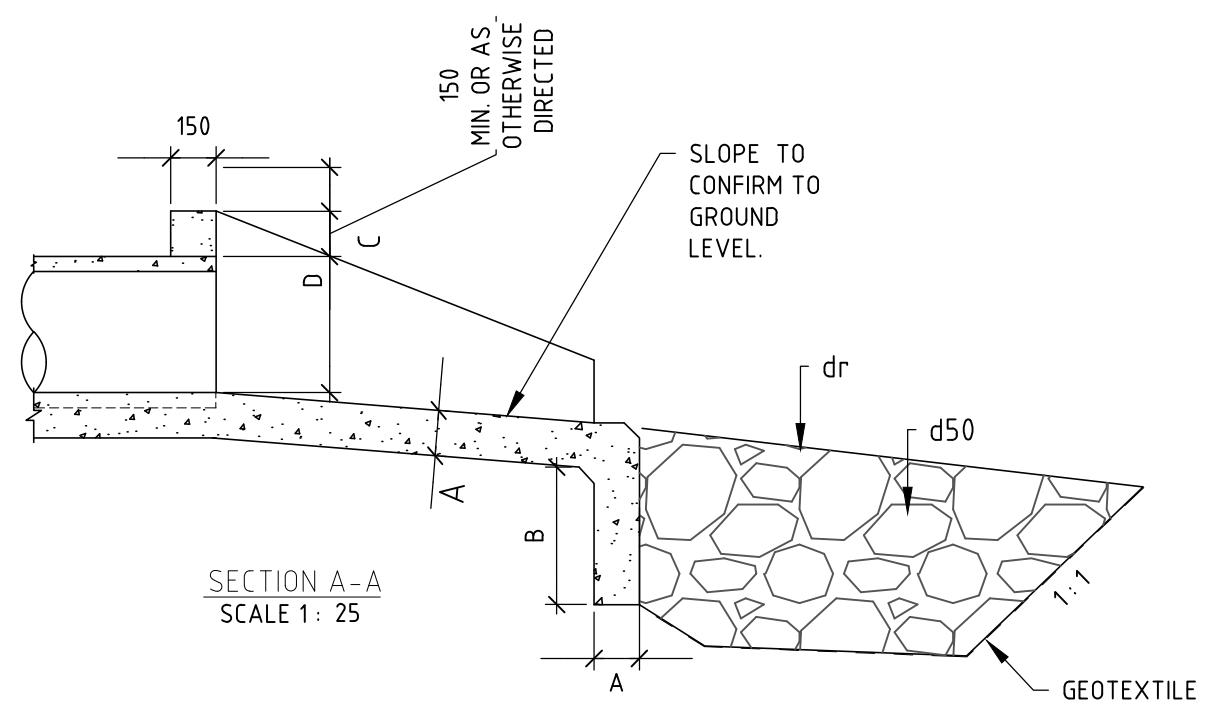

ISSUE	APP'D	DATE	AMENDMENT	BY
A				
B				
C				
D				
E				

GENERAL NOTES

STANDARD DRAWINGS		
STANDARD OUTFALL DETAIL		
ADDITIONAL EROSION PROTECTION DETAIL		
SCALE	DATE	DESIGN BY
AS SHOWN	02 MAY 17	

**Fiji Roads Authority**

DRAWN BY	APPROVED	DRAWING No.	SHEET No.	ISSUE
	A KETENILAGI	R 501 - 3	01	A

PLOT DATE 18/10/2018

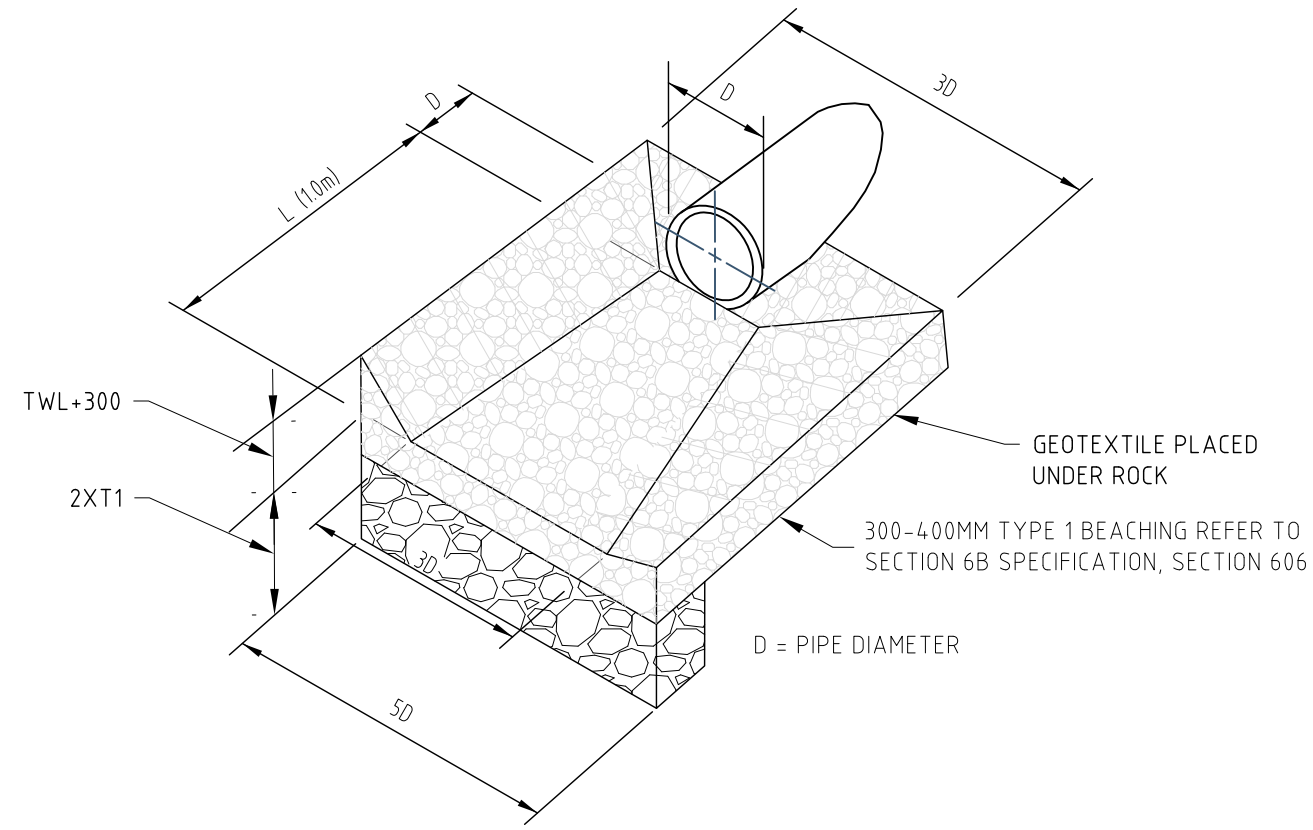

INLET / OUTLET RIP RAP -  
TYPE 1 DETAIL

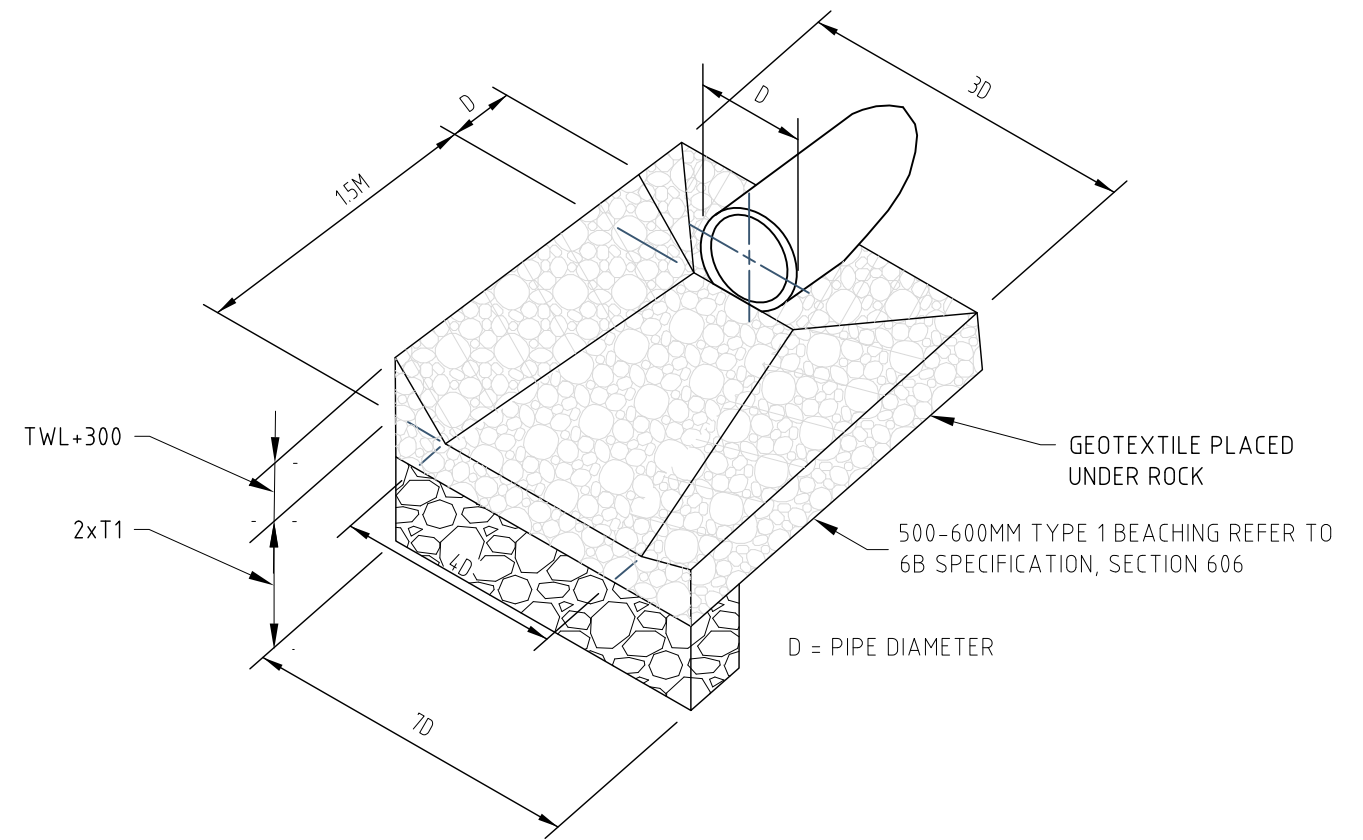

INLET / OUTLET RIP RAP -  
TYPE 2 DETAIL

**NOTES**

1. CALCULATION OF L SHALL BE IN ACCORDANCE WITH AGRD PART 5B, SECTION 3.13. ABSOLUTE MIN LENGTH SHALL BE 1.0m.
2. CALCULATION OF d50 SHALL BE IN ACCORDANCE WITH AGRD PART 5B, SEC 3.13
3. TWL = TAIL WATER LEVEL
4. FOR T1, REFER TO SUPPLEMENT 5B SECTION 3.13
5. FOR ADDITIONAL SCOUR PROTECTION ADOPT R501-3.

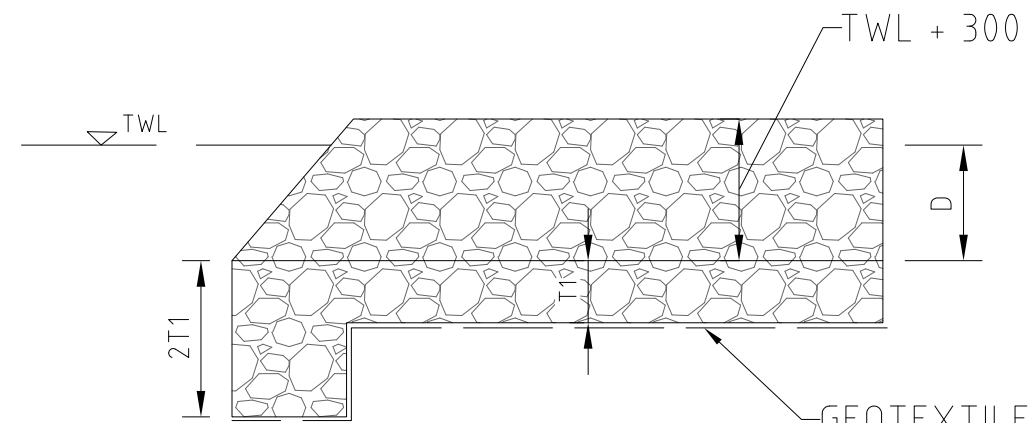

TYPICAL CROSS SECTION

A3 ORIGINAL SIZE	E				
	D				
	C				
	B				
	A				
ISSUE	APPD	DATE	AMENDMENT	BY	

GENERAL NOTES

<b>STANDARD DRAWINGS</b>		
<b>INLET / OUTLET RIPWRAP DETAIL</b>		
SCALE	DATE	DESIGN BY
	05 April 17	

**Fiji Roads Authority**

DRAWN BY	APPROVED	DRAWING No.	SHEET No.	ISSUE
CWS		R 501 - 4	01	

PLOT DATE 18/10/2018

150

100

50

40

30

20

10

A3 ORIGINAL SIZE

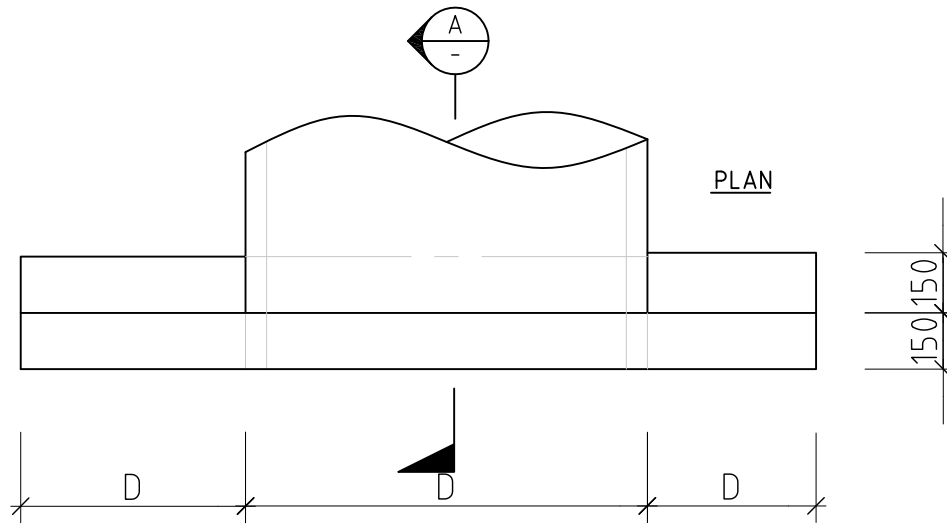

D	T1
<450	500
>450	600

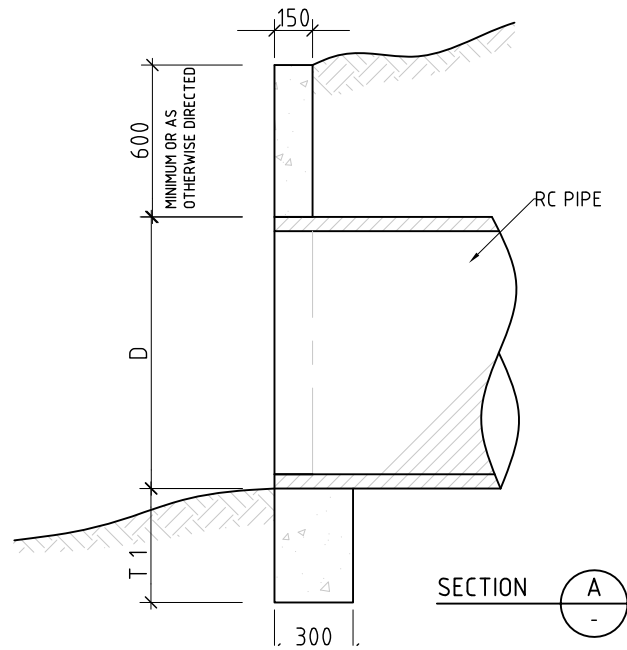

**NOTES**  
 1. FOR SCOUR PROTECTION REFER R501/6

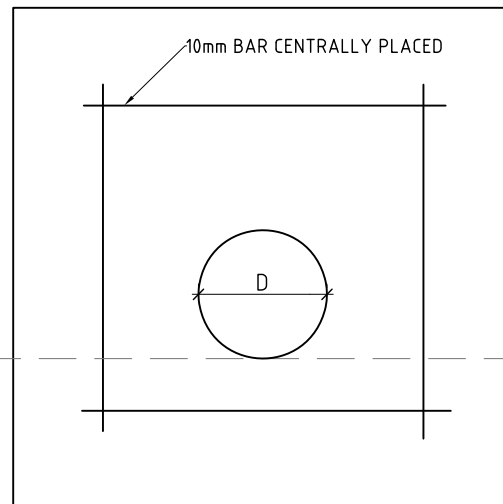

- NOTE**
- DIMENSIONS MAY BE VARIED ACCORDING TO ENGINEERS DIRECTIONS
  - CONCRETE STRENGTH TO BE 25MPa AT 28 DAYS

E				
D				
C				
B				
A				
ISSUE	APPD	DATE	AMENDMENT	BY

GENERAL NOTES

<b>STANDARD DRAWINGS</b>	
<b>STANDARD HEADWALL DETAIL</b>	
SCALE As Shown	DATE 05 April 17
DESIGN BY	DRAWN BY
APPROVED	ISSUE

Fiji Roads Authority

DRAWING No. R 501 - 5	SHEET No. 01	ISSUE
--------------------------	-----------------	-------

PLOT DATE 04/12/2019

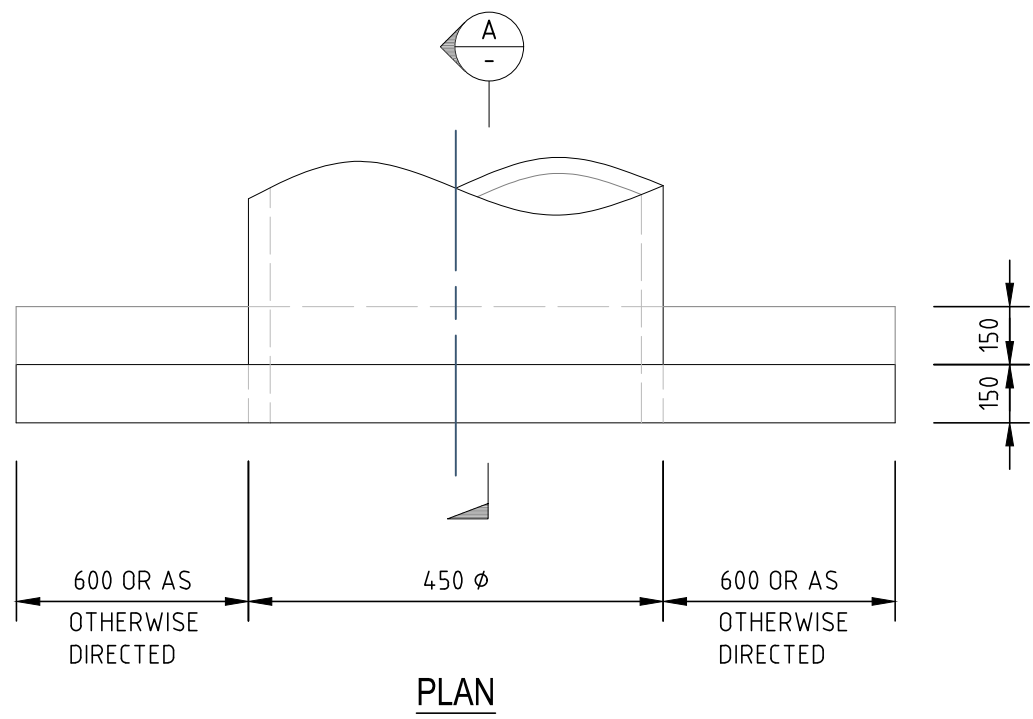

**PLAN**

**NOTE**

- DIMENSIONS MAY BE VARIED ACCORDING TO ENGINEERS DIRECTIONS.
- CONCRETE STRENGTH TO BE 25MPa AT 28 DAYS.
- d50 = 300MM (REFER TO AUSTRROADS GUIDE TO ROAD DESIGN (AGRD), PART 5B SECTION 3.13).
- dr = 2xd50, REFER ALSO TO AUSTRROADS GUIDE TO ROAD DESIGN (AGRD) PART 5L, SECTION 3.13.

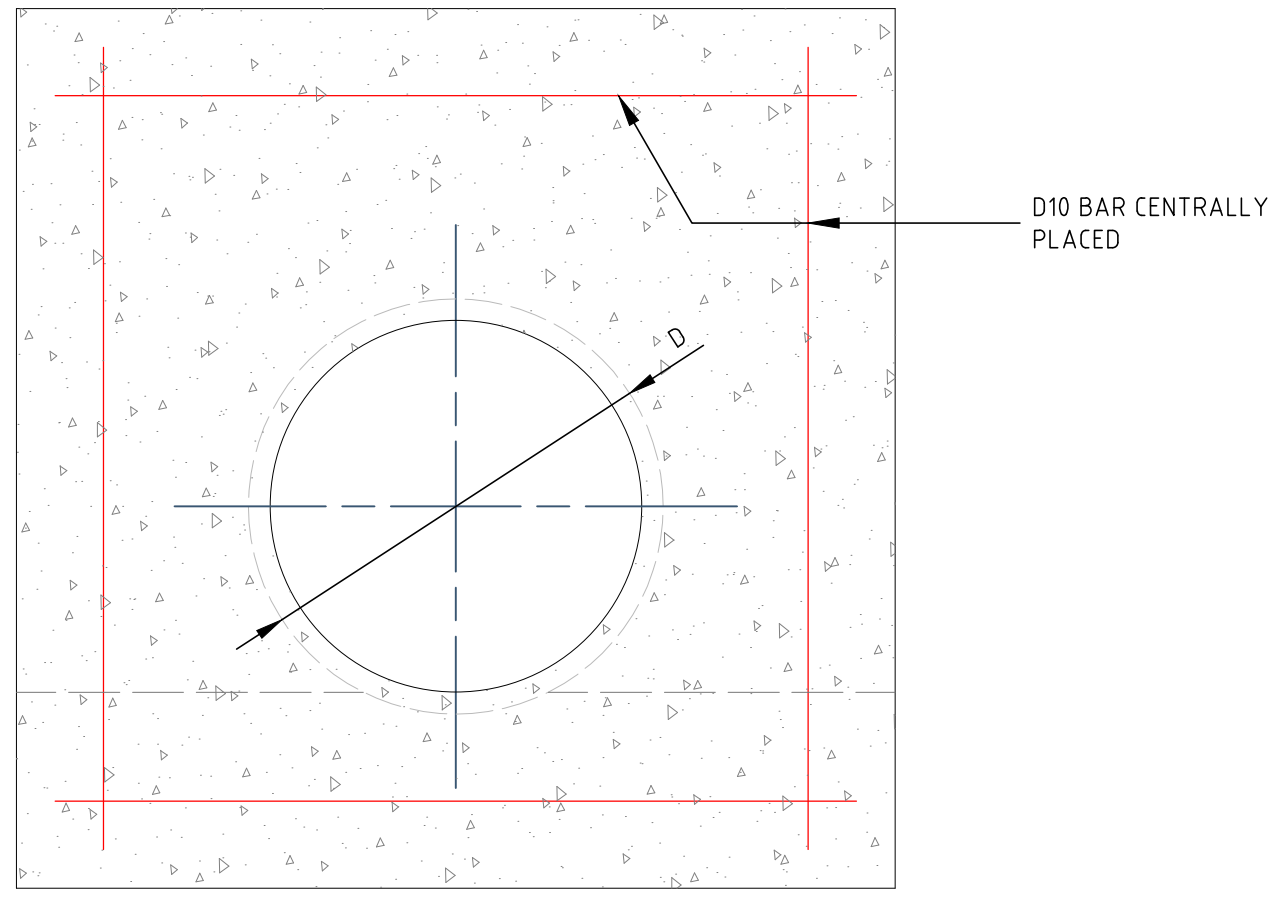

**ELEVATION**

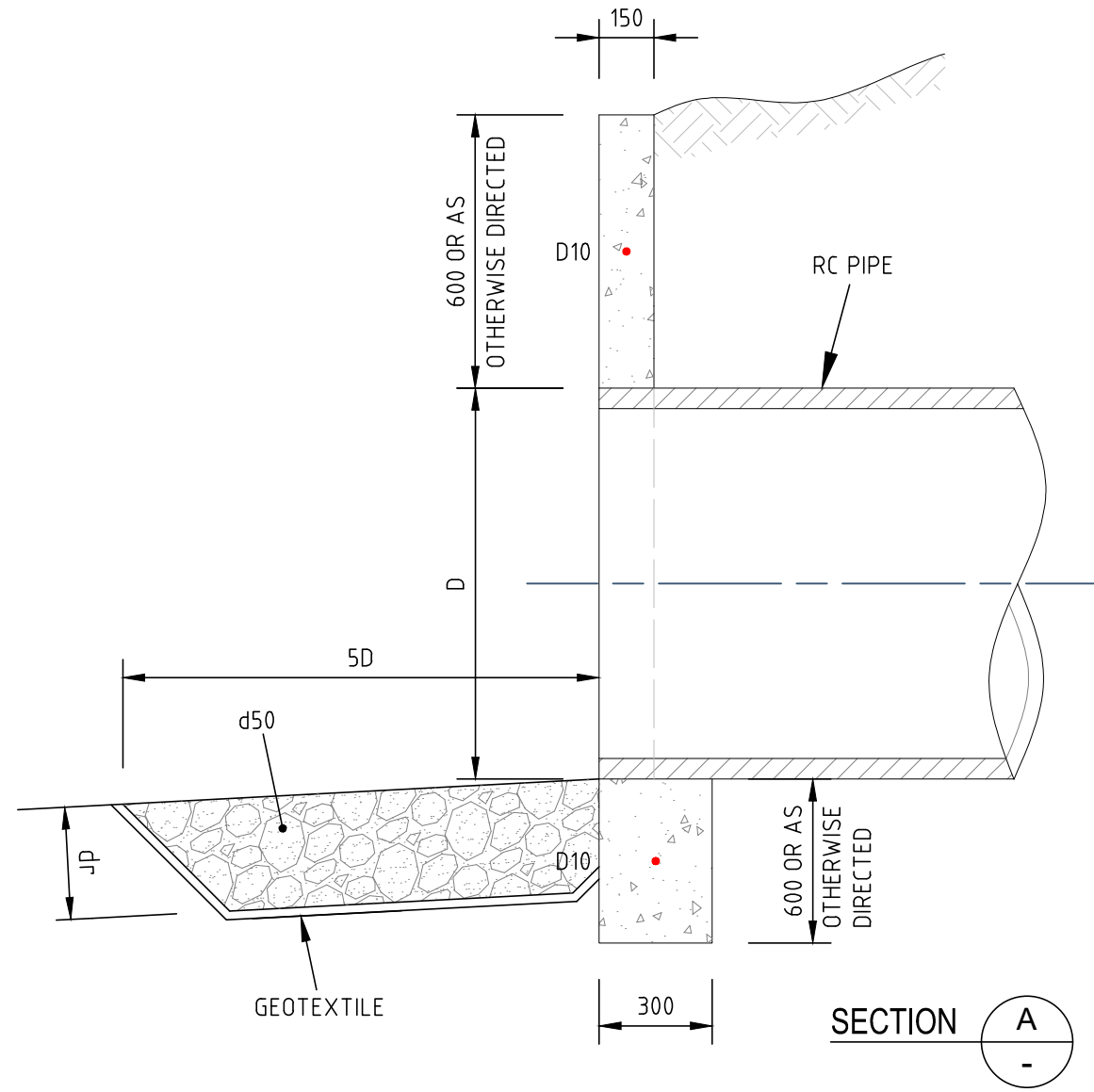

**SECTION A**

A3 ORIGINAL SIZE	E			
	D			
	C			
	B			
	A			
ISSUE	APP'D	DATE	AMENDMENT	BY

GENERAL NOTES

**STANDARD DRAWINGS**  
**STANDARD HEADWALL DETAIL**  
**ADDITIONAL EROSION PROTECTION DETAILS**



SCALE	DATE 29 NOVEMBER 19	DESIGN BY	DRAWN BY S. FREMLIN	APPROVED M. DALE	DRAWING No. R 501 - 6	SHEET No. 01	ISSUE
-------	------------------------	-----------	------------------------	---------------------	--------------------------	-----------------	-------

PLOT DATE 18/10/2018

150

100

50

40

30

20

10

A3 ORIGINAL SIZE

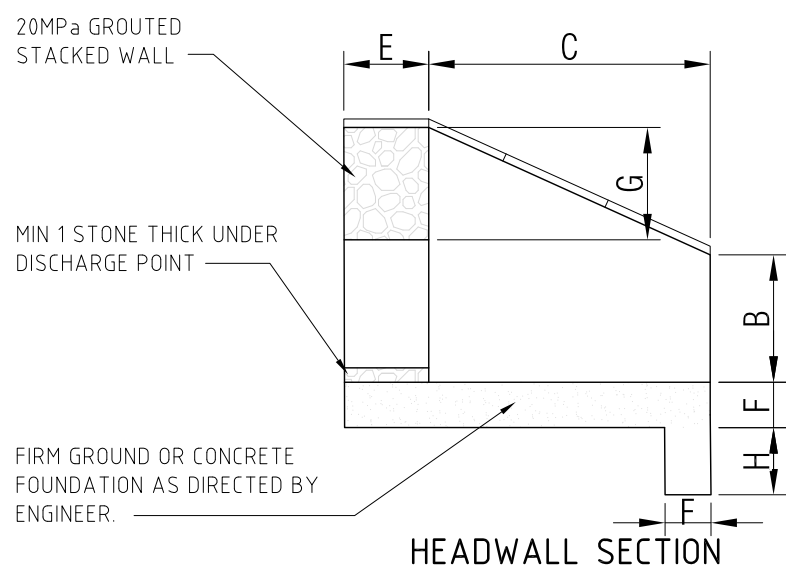
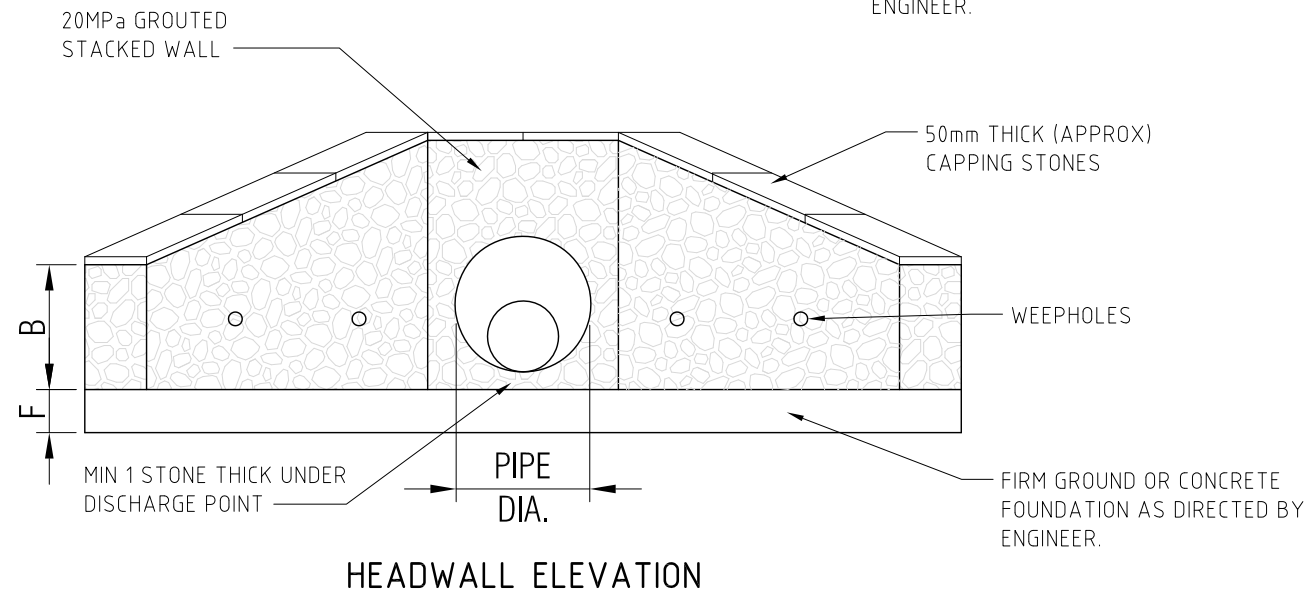
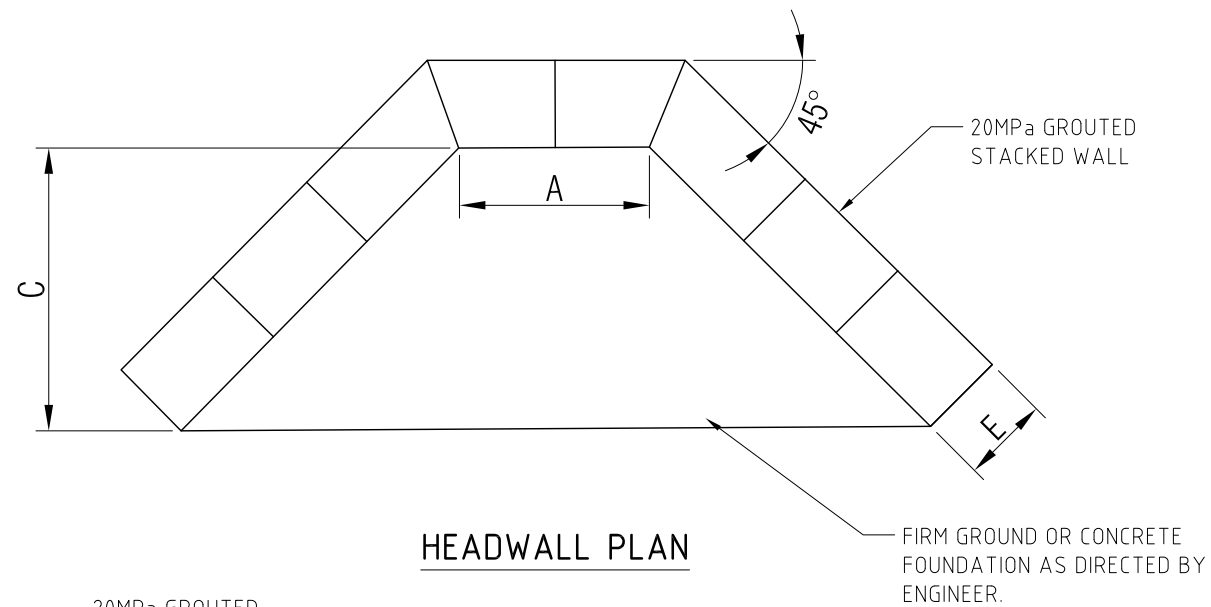

PIPE DIA	PRINCIPAL DIMENSIONS (mm)							
	A	B	C	D	E	F	G	H
600	1200	550	1200	-	250	150	250	600
900	1500	650	1800	-	250	200	250	900
1200	2100	1000	2000	-	300	250	300	900

- NOTE:
1. STONE TO BE APPROVED FOR USE BY ENGINEER PRIOR TO INSITU CONSTRUCTION.
  2. DIMENSIONS TO BE AMENDED ONSITE AS APPROPRIATE TO SUIT EXISTING GROUND LEVELS.
  3. FOR ADDITIONAL SCOUR PROTECTION DETAILS REFER R501.

ISSUE	APPD	DATE	AMENDMENT	BY
E				
D				
C				
B				
A				

GENERAL NOTES

STANDARD DRAWINGS			
STACKED STONE ENDWALL DETAIL			
SCALE	DATE	DESIGN BY	DRAWN BY
	05 April 17		CWS

Fiji Roads Authority

APPROVED	DRAWING No.	SHEET No.	ISSUE
	R 501 - 7	01	

PLOT DATE 05/02/2020

150

100

50

40

30

20

10

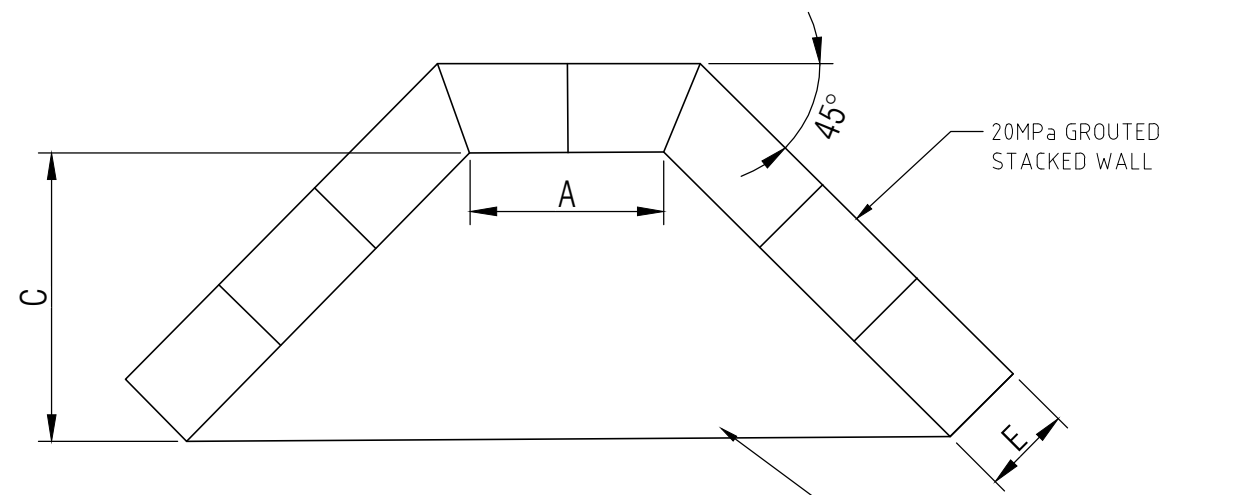

**HEADWALL PLAN**

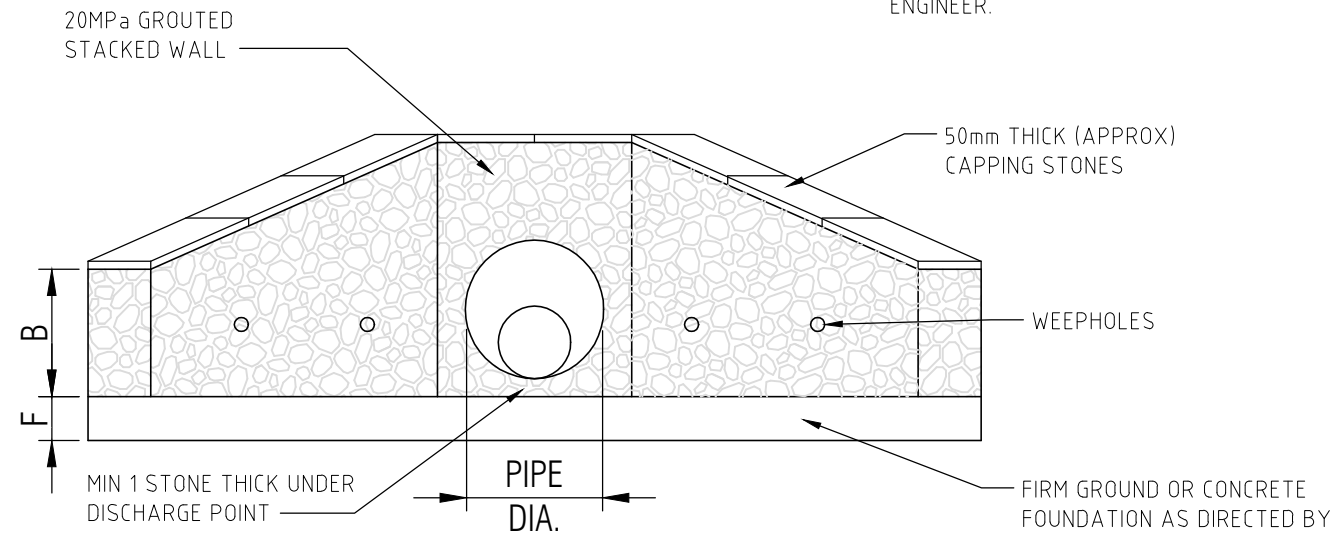

**HEADWALL ELEVATION**

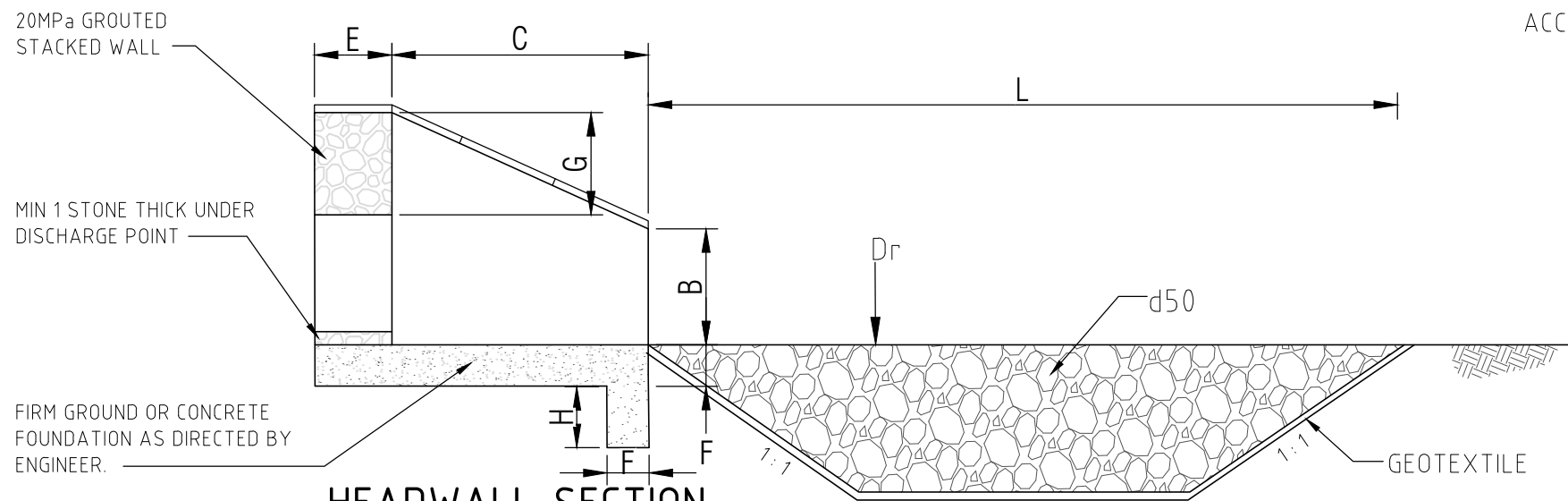

**HEADWALL SECTION**

PIPE DIA	PRINCIPAL DIMENSIONS (mm)							
	A	B	C	D	E	F	G	H
450	900	415	900	-	200	150	200	450
600	1200	550	1200	-	250	150	250	600
900	1500	650	1800	-	250	200	250	900
1200	2100	1000	2000	-	300	250	300	900

**NOTE:**

1. STONE TO BE APPROVED FOR USE BY ENGINEER PRIOR TO INSITU CONSTRUCTION.
2. DIMENSIONS TO BE AMENDED ONSITE AS APPROPRIATE TO SUIT EXISTING GROUND LEVELS.
3. CALCULATION OF L, d50 AND Dr SHALL BE IN ACCORDANCE WITH AGRD PART 5b SECTION 3.13.

ISSUE	APP'D	DATE	AMENDMENT	BY
A		5/02/2020	INCLUSION 450 DIAMETER PIPE	A.K

GENERAL NOTES

STANDARD DRAWINGS		
<b>STACKED STONE ENDWALL DETAIL EROSION PROTECTION DETAILS</b>		
SCALE	DATE	DESIGN BY
	05 FEB 2020	

Fiji Roads Authority

DRAWN BY	APPROVED	DRAWING No.	SHEET No.	ISSUE
CWS		R 501 - 8	01	

NOTES:

- 1 THESE ENDWALLS ARE DESIGNED FOR USE IN AREAS WHERE HEAD ON COLLISIONS ARE LIKELY TO OCCUR
- 2 REINFORCEMENT, F81 UNLESS OTHERWISE SPECIFIED, SHALL BE CONTINUOUS AROUND CORNERS AND LOCATED AS SHOWN.  
CLEAR COVER 50 MIN LAPS-FABRICS 300 MIN, BARS 25 X BAR DIAMETER MIN
- 3 DISTRIBUTION BARS 12 DIA AT 200 CENTRES
- 4 CONCRETE SHALL BE NORMAL-CLASS N32 STANDARD STRENGTH GRADE OR HIGHER COMPLYING WITH THE REQUIREMENTS OF AS 1379. EXPOSURE CLASSIFICATIONS UP TO AND INCLUDING B1
5. EXPOSED EDGES SHALL HAVE 20 x 20 CHAMFERS.
6. RAILS WITHIN SECTION "L" SHALL BE EVENLY SPACED.  
THE MAXIMUM SPACING SHALL NOT EXCEED 600mm
- 7 RAILS ARE 60 3mm DIAMETER GALVANISED TUBES 5 4mm THICK  
THESE ARE TO BE GROUTED INTO THE SLOTS IN THE WALLS
- 8 SLOPE OF ENDWALL TO MATCH BATTER SLOPE MAXIMUM SLOPE 4 TO 1
- 9 CONCRETE AGGREGATES SHALL COMPLY WITH FRA STANDARD SPECIFICATION
- 10 ENDWALLS SHALL BE CONSTRUCTED IN ACCORDANCE WITH THE RELEVANT PROVISIONS OF AS 3600.

L (mm)	TOTAL NUMBER OF RAILS
100 - 600	1
601 - 1200	2
1201 - 1800	3
1801 - 2400	4

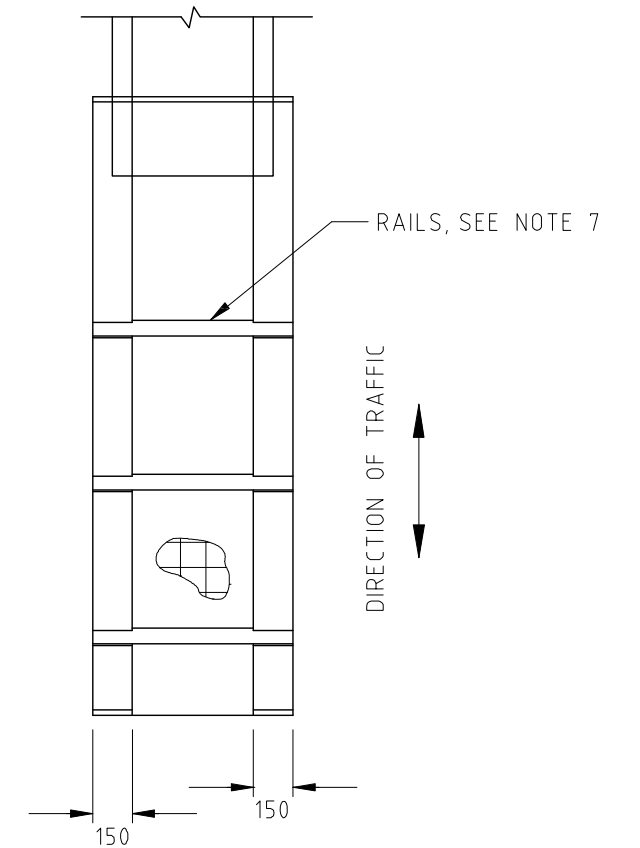

PLAN

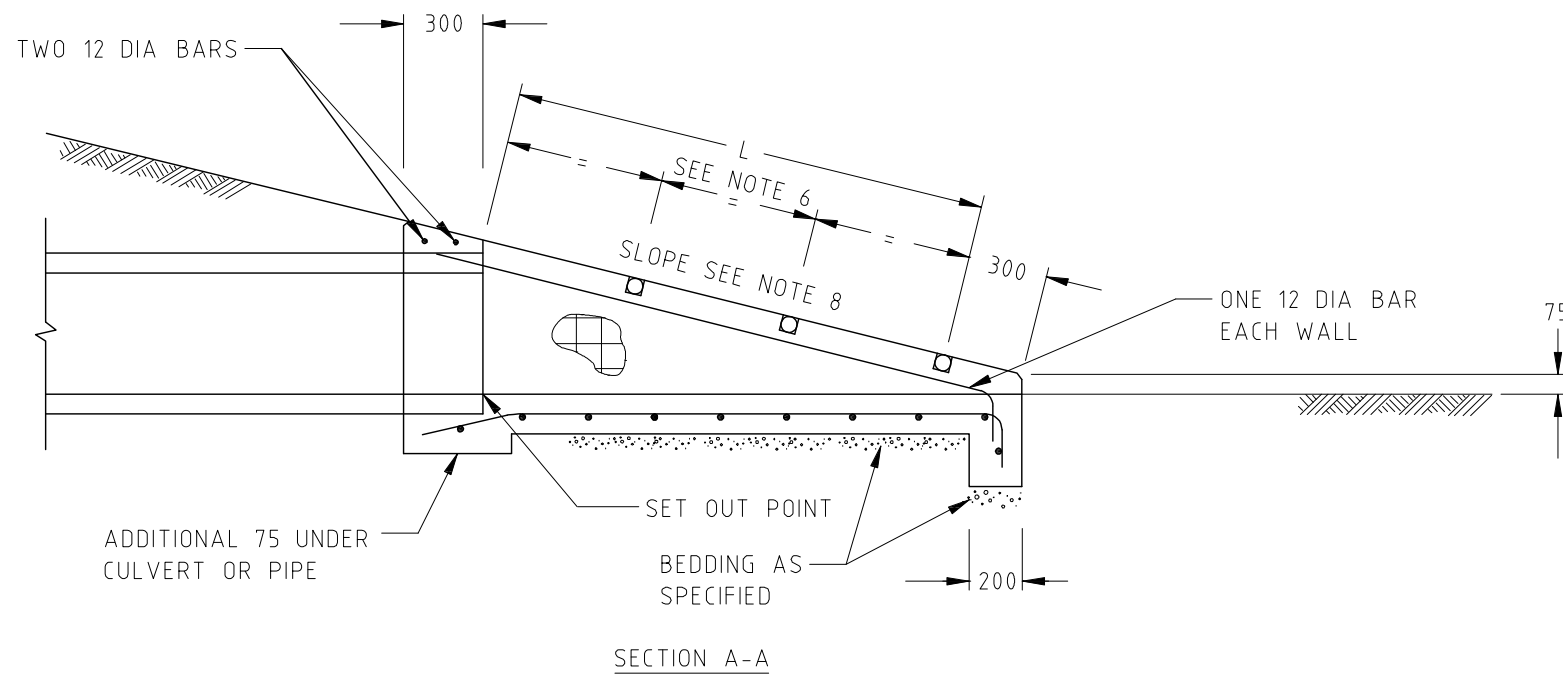

SECTION A-A

TWO 12 DIA BARS, 300 MIN EMBEDMENT INTO SIDE WALLS

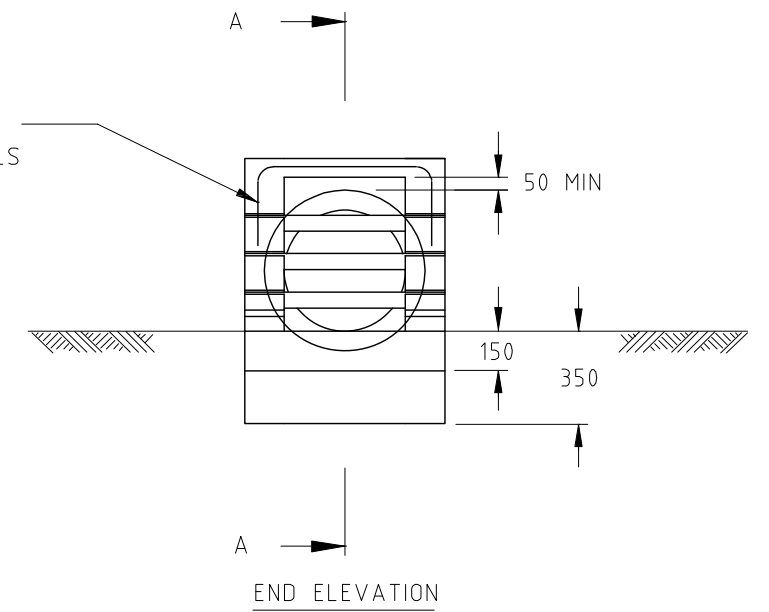

END ELEVATION

PLOT DATE 18/10/2018

150

100

50

40

30

20

10

A3 ORIGINAL SIZE

ISSUE	APPD	DATE	AMENDMENT	BY
E				
D				
C				
B				
A				

GENERAL NOTES

**STANDARD DRAWINGS**  
**DRIVEABLE CULVERT ENDWALLS (TYPE 1)**  
 PIPE CULVERTS UP TO 600 DIA AND  
 BOX CULVERTS UP TO 600mm WIDE.

SCALE	DATE	DESIGN BY	DRAWN BY	APPROVED	DRAWING No.	SHEET No.	ISSUE
	05 April 17		CWS		R 501 - 9	01	

Fiji Roads Authority

PLOT DATE 18/10/2018

150

100

50

40

30

20

10

NOTES:

- 1 REINFORCEMENT, F81 UNLESS OTHERWISE SPECIFIED, SHALL BE CONTINUOUS, AROUND CORNERS AND LOCATED AS SHOWN.  
CLEAR COVER 50 MIN LAPS FABRICS 300 MIN, BARS 25 X BAR DIAMETER MIN
- 2 SLOPE OF ENDWALL TO MATCH BATTER SLOPE MAXIMUM SLOPE 4 TO 1 MINIMUM SLOPE 6 TO 1
- 3 CONCRETE SHALL BE NORMAL-CLASS N32 STANDARD STRENGTH GRADE OR HIGHER COMPLYING WITH THE REQUIREMENTS OF AS 1329 EXPOSURE CLASSIFICATIONS UP TO INCLUDING B1.
4. EXPOSED EDGES SHALL HAVE 20 x 20 CHAMFERS.
5.  $d$  = INTERNAL DIAMETER OF PIPE (OR HEIGHT OF BOX).
- 6 CONCRETE AGGREGATES SHALL COMPLY WITH FRA STANDARD SPECIFICATION
- 7 ENDWALLS SHALL BE CONSTRUCTED IN ACCORDANCE WITH THE RELEVANT PROVISIONS OF AS 3600

PARALLEL VERTICAL WALLS  
200 THICK

BATTER LINE

BATTER LINE

12 DIA BARS AT 200 CRS OR  
LAP FABRIC AS PER NOTE 1

CUT-OFF WALL  
200 THICK

DIRECTION OF TRAFFIC

3d 3d

PLAN

LIMIT OF CLEAR ZONE

TWO 12 DIA BARS

300

12 DIA BARS

30mm COVER TO  
TOP OF PIPE.

SLOPE SEE NOTE 2

DRIVEABLE  
BEACHING

BEACHING  
AS REQUIRED

3d

$d/2$  MIN

ADDITIONAL 75 UNDER  
CULVERT OR PIPE

SET OUT POINT

BEDDING AS  
SPECIFIED

200

TWO 12 DIA BARS , 300 MIN  
EMBEDMENT INTO VERTICAL WALLS

$d$  MIN

6:1

$d$

6:1

30 MIN

200

END ELEVATION

SECTION A-A

A3 ORIGINAL SIZE	E				
	D				
	C				
	B				
	A				
ISSUE	APP'D	DATE	AMENDMENT	BY	

GENERAL NOTES

**STANDARD DRAWINGS**  
**DRIVEABLE CULVERT ENDWALLS (TYPE 2)**  
 PIPE CULVERTS UP TO 600 DIA AND  
 BOX CULVERTS UP TO 600mm WIDE.

SCALE	DATE	DESIGN BY	DRAWN BY	APPROVED	DRAWING No.	SHEET No.	ISSUE
	05 April 17		CWS		R 501 - 10	01	



**Fiji Roads Authority**

DRAWN BY	APPROVED	DRAWING No.	SHEET No.	ISSUE
CWS		R 501 - 10	01	

PLOT DATE 18/10/2018

150

100

50

40

30

20

10

A3 ORIGINAL SIZE

STANDING LOADING

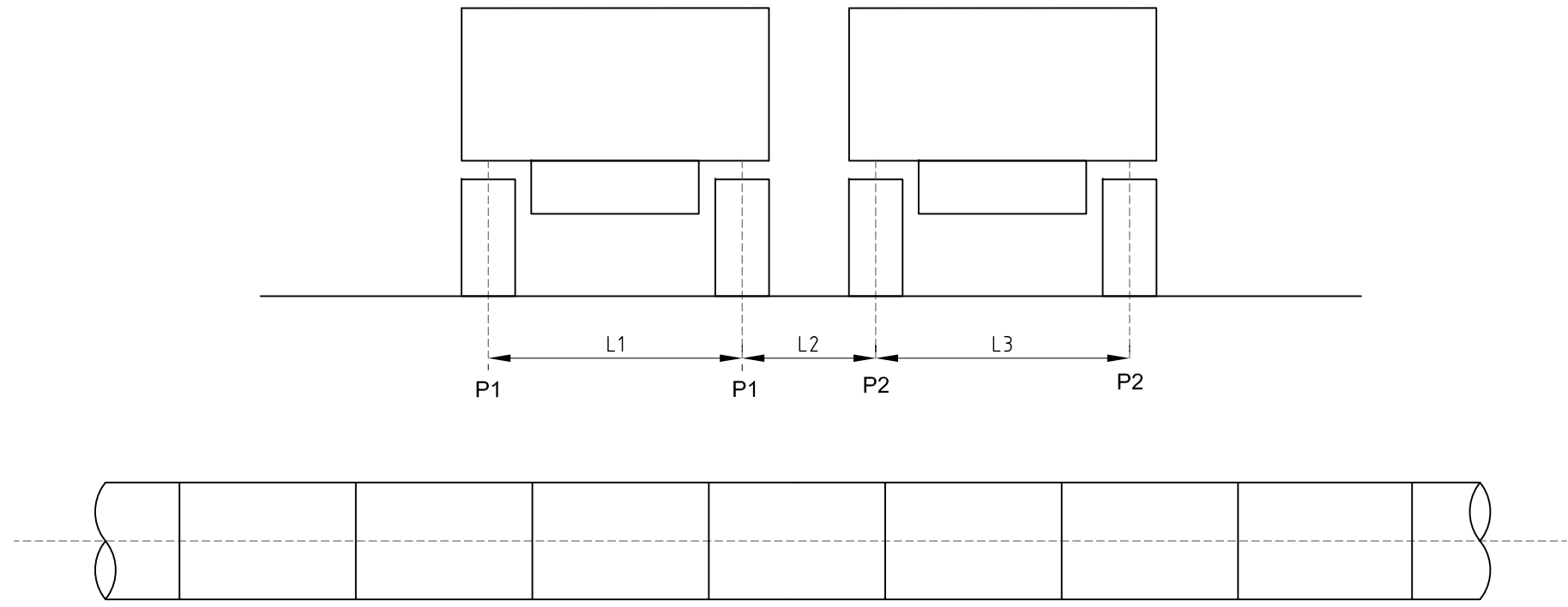

LOADING DIAGRAM

WHEEL LOADS AND SPACINGS					
VEHICLE TYPE	P1 (KN)	P2 (KN)	L1 (m)	L2 (m)	L3 (m)
M1600	120	96	8.10	1.05	1.8
S1600	80	64	8.10	1.05	1.8
T44	96	96	8.10	1.05	1.8
H80	72	72	1.83	1.22	1.83
H15	54	54	1.83	1.22	1.83
H10	36	36	1.83	1.22	1.83

DYNAMIC LOAD ALLOWANCE		
FOR FILL OVER PIPE :		
H = 0		40%
H = 1		25%
H = 2 OR ABOVE		10%

E				
D				
C				
B				
A				
ISSUE	APPD	DATE	AMENDMENT	BY

GENERAL NOTES

STANDARD DRAWINGS  
EFFECTS OF TRAFFIC LOADS ON  
CONCRETE PIPES

SCALE	DATE	DESIGN BY
	01 MAY 17	



**Fiji Roads Authority**

DRAWN BY	APPROVED	DRAWING No.	SHEET No.	ISSUE
CWS	A KETENILAGI	R 501 - 11	01	A

PERMISSIBLE DEPTHS OF FILLING OVER R.C. PIPES INSTALLED IN THE  
THE EMBANKMENT CONDITION WITH TYPE B BEDDING:

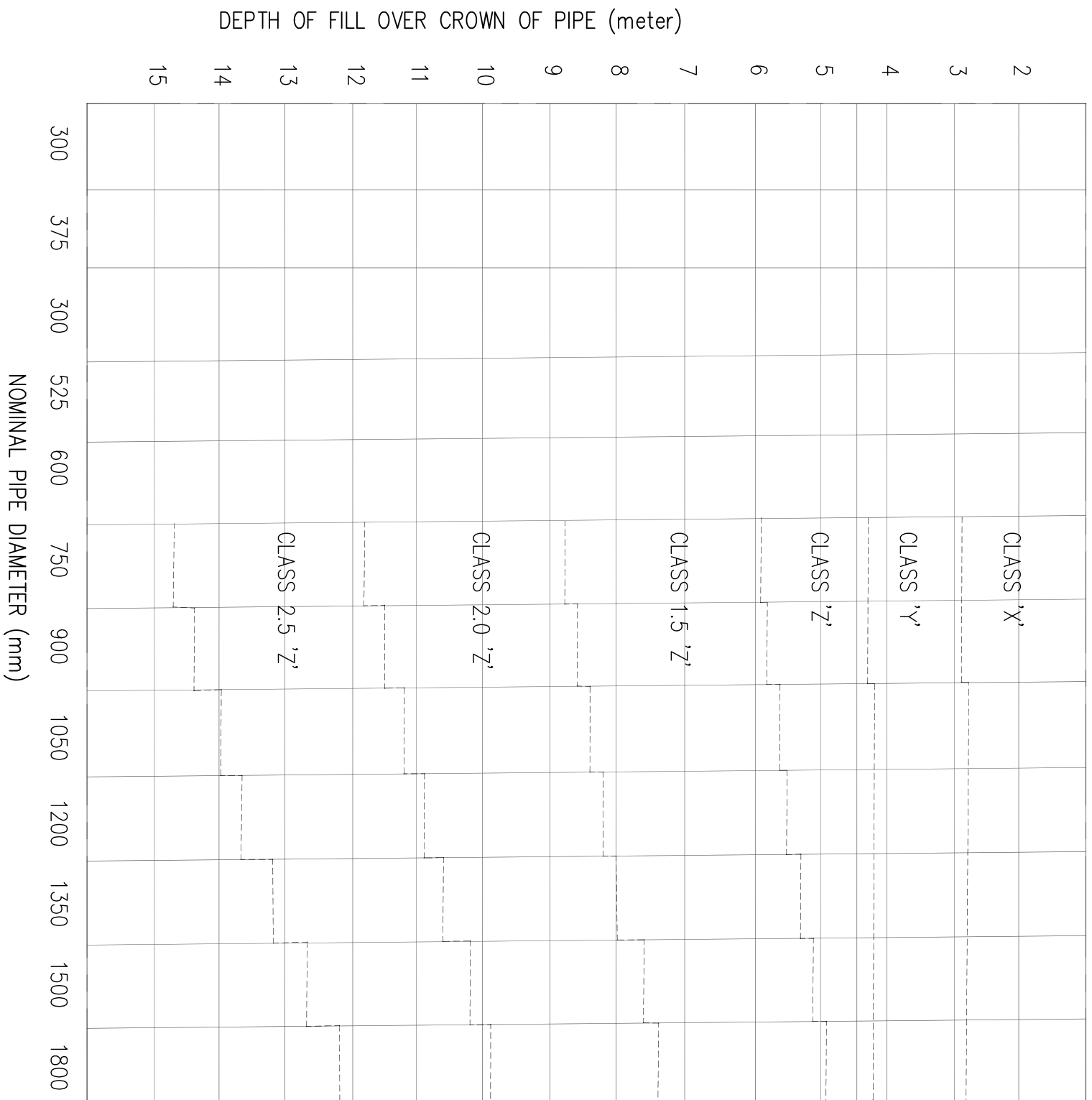

BEDDING : TYPE B  
 FOUNDATION : EARTH  
 SETTLEMENT RATIO : 0.7  
 PROJECTION RATIO : 0.7  
 DENSITY OF FILL : 2000 Kg/m<sup>3</sup>

- FOR ROCK FOUNDATION REDUCE ALLOWABLE HEIGHT BY 4
- FOR FILL DENSITY OF 2250 Kg/m<sup>3</sup> REDUCE ALLOWABLE HEIGHT BY 10%
- FOR FILL DENSITY OF 1750 Kg/m<sup>3</sup> INCREASE ALLOWABLE HEIGHT BY 15%
- FOR FILL DENSITY OF 1500 Kg/m<sup>3</sup> INCREASE ALLOWABLE HEIGHT BY 30%.

2018/10/02 DATE PLOT

151

101

05

07

30

02

01

SIZE ORIGINAL A3

E				
D				
C				
B				
A				
ISSUE	APPD	DATE	AMENDMENT	BY

GENERAL NOTES

STANDARD DRAWINGS		
PERMISSIBLE DEPTHS OF FILLING OVER RC PIPES EMBANKMENT CONDITION.		
SCALE	DATE	DESIGN BY
	01 MAY 17	



**Fiji Roads Authority**

DRAWN BY	APPROVED	DRAWING No.	SHEET No.	ISSUE
CWS	A KETENILAGI	R 501 - 12	01	A

PERMISSIBLE DEPTHS OF FILLING OVER R.C. PIPES INSTALLED IN THE TRENCH CONDITION WITH TYPE B BEDDING:

CLAY  
W = 2000 Kg/m<sup>3</sup>

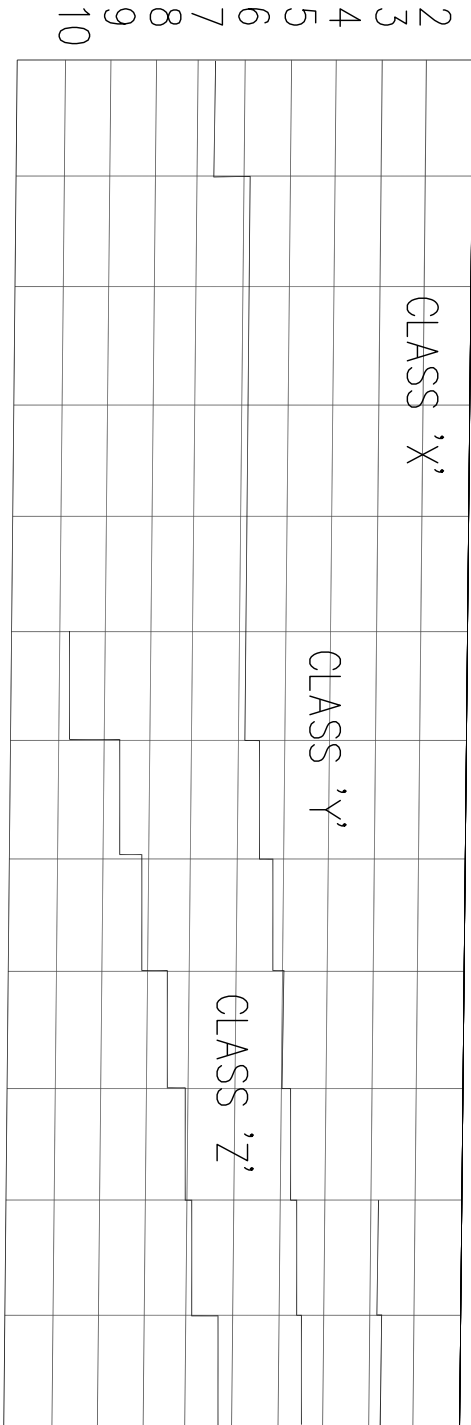

SANDY CLAY  
W = 1750 Kg/m<sup>3</sup>

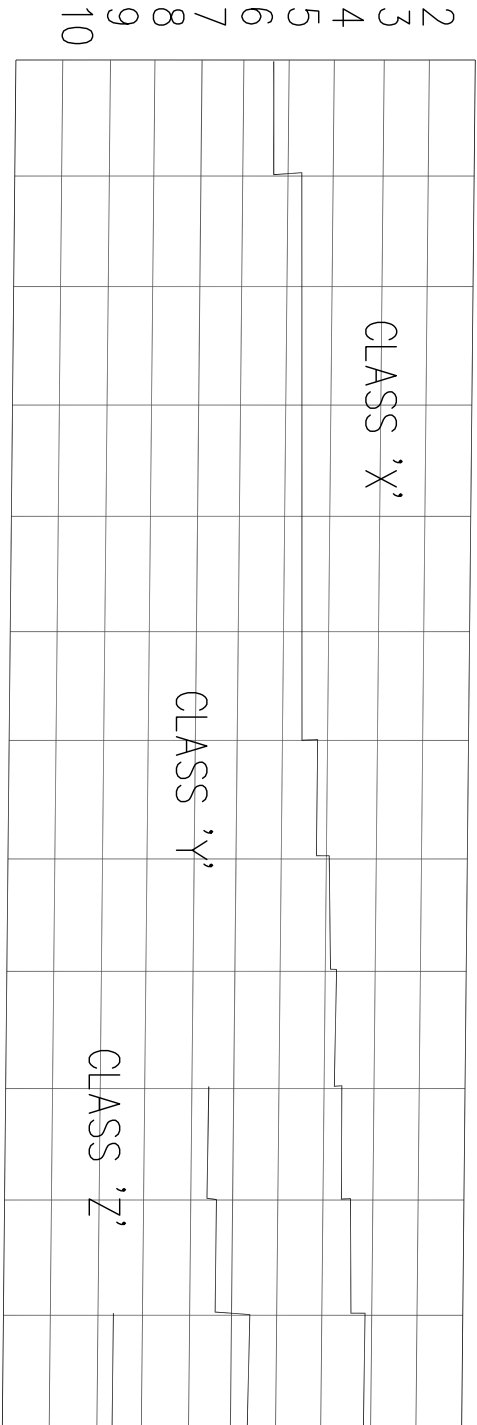

GRANULAR  
W = 1750 Kg/m<sup>3</sup>

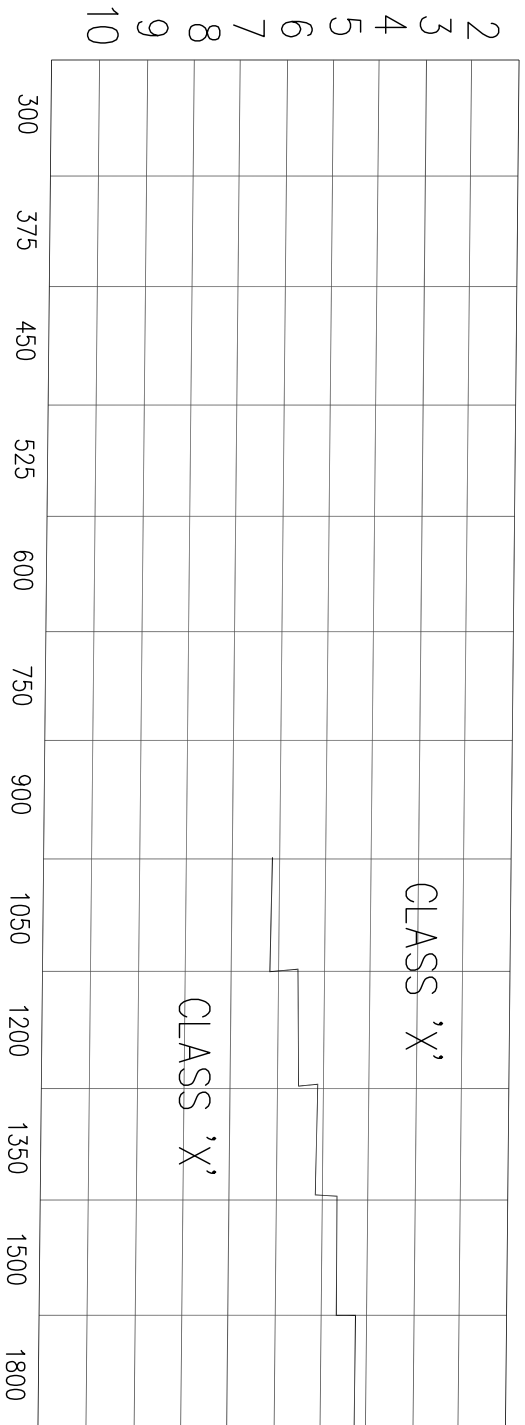

BEDDING : TYPE B  
 FOUNDATION : EARTH OR ROCK  
 TRENCH WIDTH : 4 OVER 3 O.D. + 400  
 LOAD FACTOR : 2.5

PLOT DATE 18/10/2018

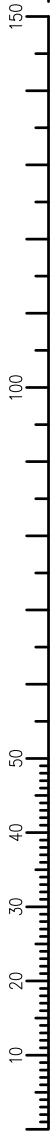

A3 ORIGINAL SIZE

ISSUE	APPD	DATE	AMENDMENT	BY
E				
D				
C				
B				
A				

GENERAL NOTES

STANDARD DRAWINGS  
 PERMISSIBLE DEPTHS OF FILLING OVER RC  
 PIPES IN TRENCH CONDITION.



Fiji Roads Authority

SCALE	DATE 01 MAY 17	DESIGN BY	DRAWN BY CWS	APPROVED A KETENILAGI	DRAWING No. R 501 - 13	SHEET No. 01	ISSUE A
-------	-------------------	-----------	-----------------	--------------------------	---------------------------	-----------------	------------

PLOT DATE 12/03/2019

150

100

50

40

30

20

10

A3 ORIGINAL SIZE

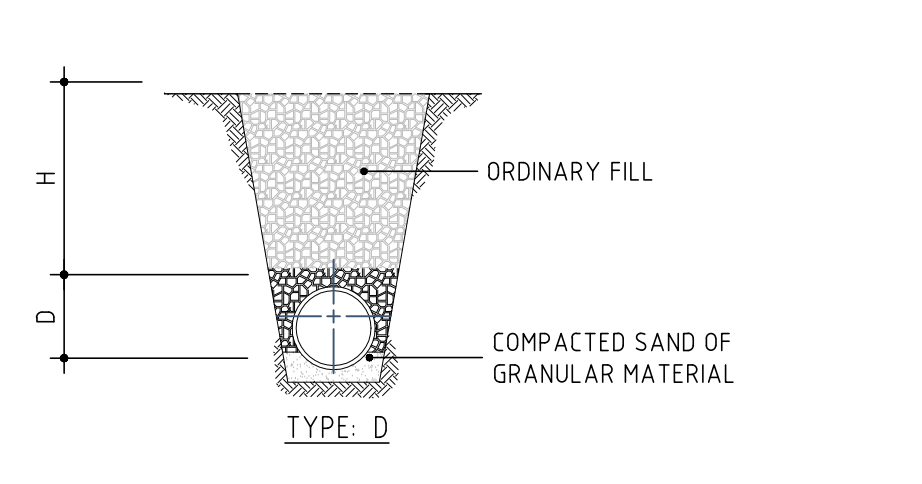
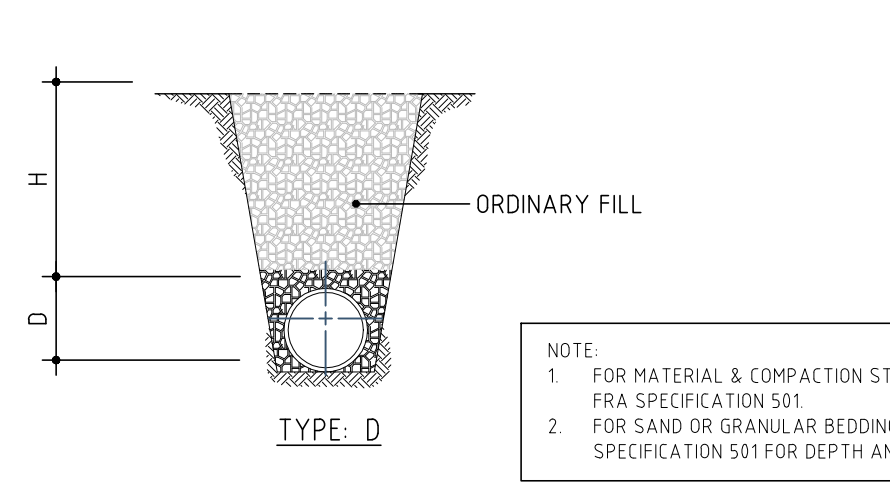
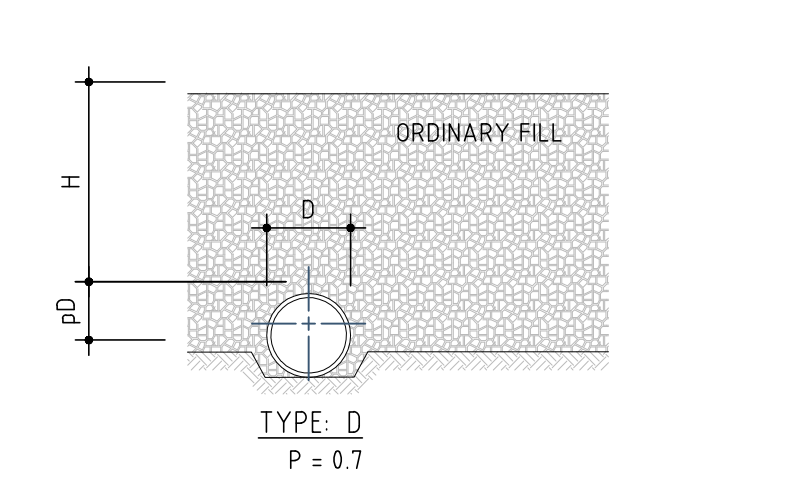
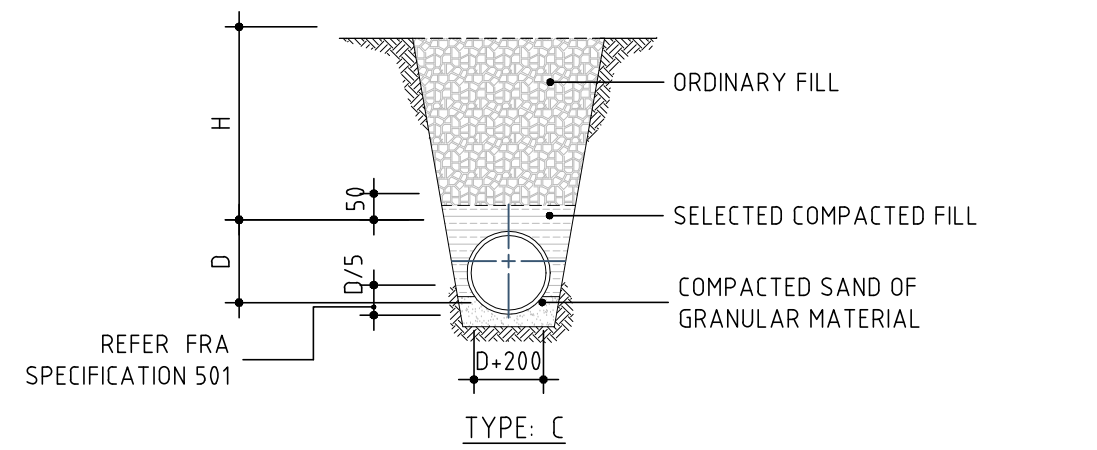
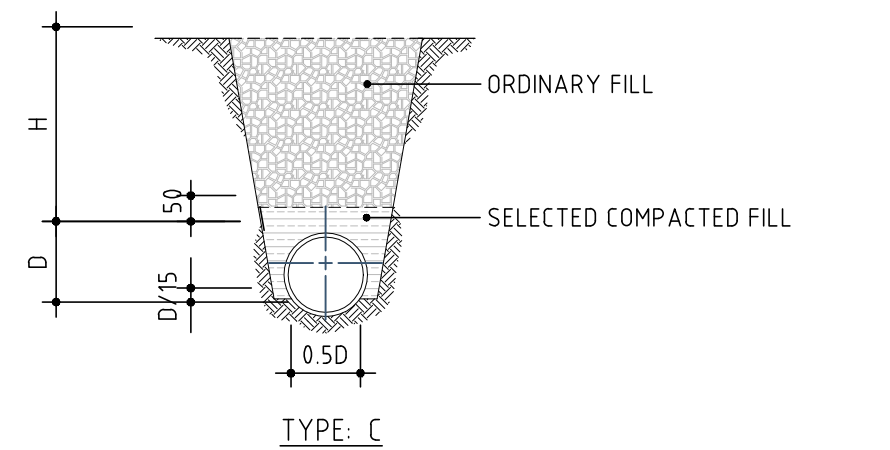
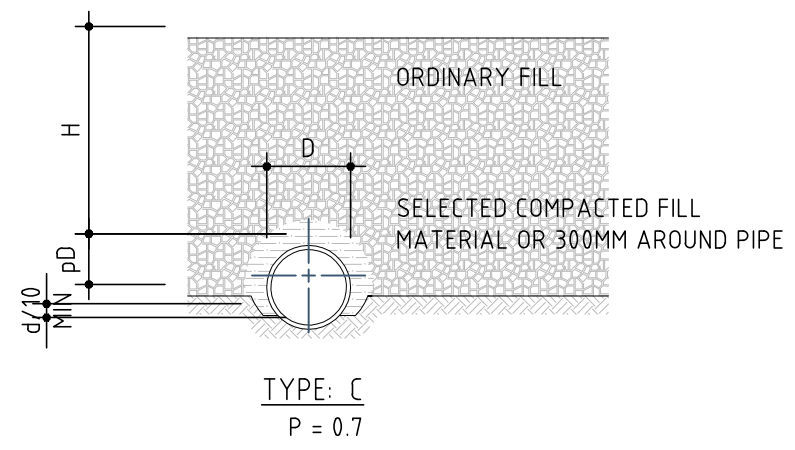
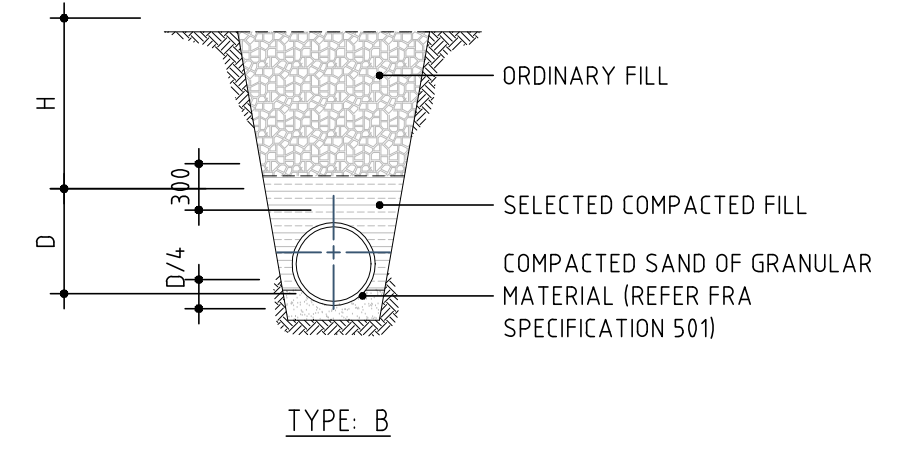
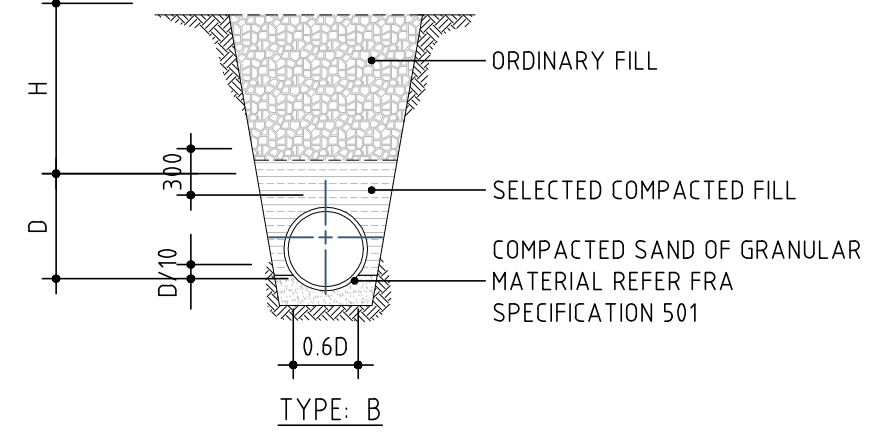
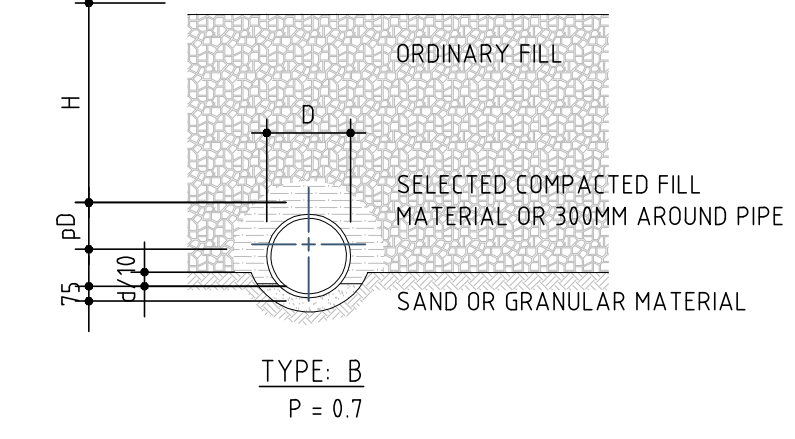
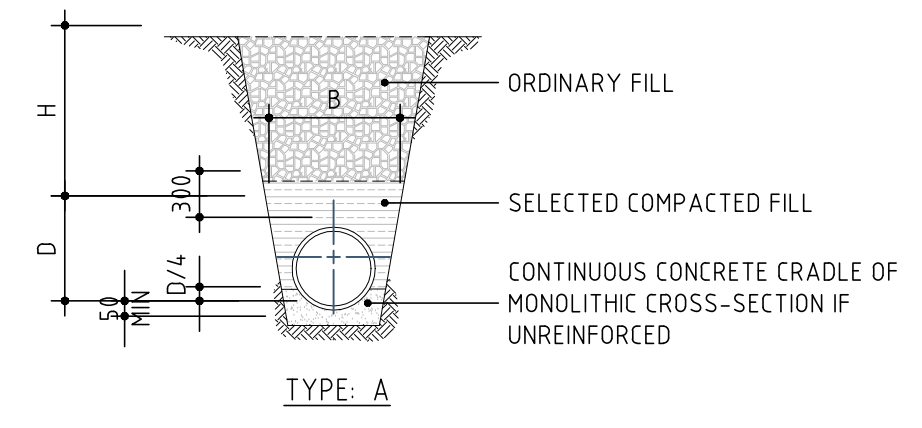
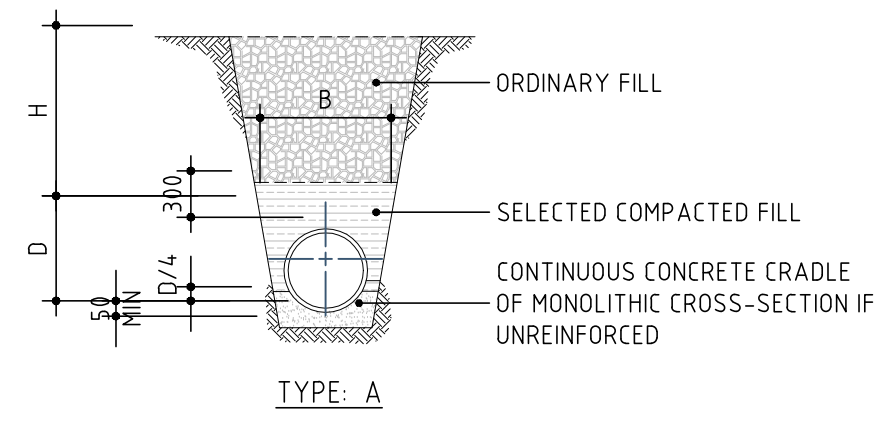
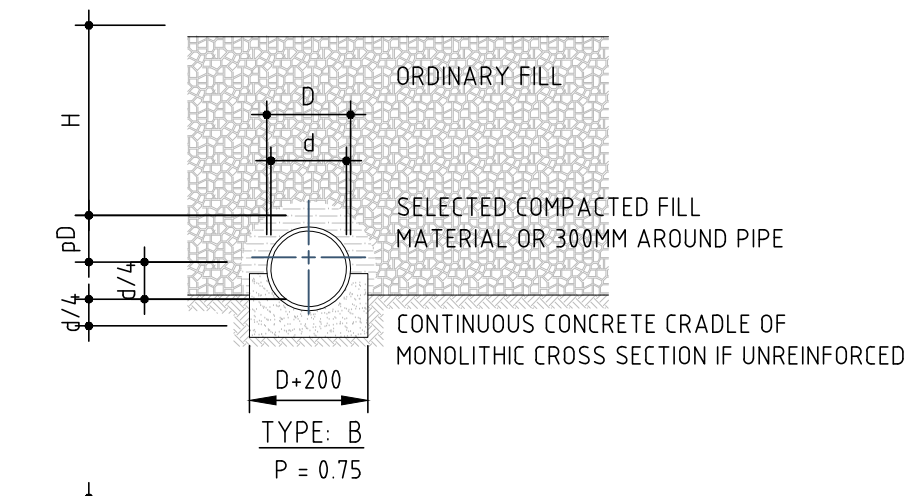

NOTE:  
1. FOR MATERIAL & COMPACTION STANDARDS REFER FRA SPECIFICATION 501.  
2. FOR SAND OR GRANULAR BEDDING REFER FRA SPECIFICATION 501 FOR DEPTH AND TRENCH WIDTH.

GENERAL NOTES  
1. Batter sloped for trenching based on depth and shoring shall be subject to Fiji trenching regulations.

STANDARD DRAWINGS  
CONCRETE PIPES UNDER EMBANKMENT ON EARTH



ISSUE	APP'D	DATE	AMENDMENT	BY
E				
D				
C				
B				
A				

SCALE	DATE	DESIGN BY	DRAWN BY	APPROVED	DRAWING No.	SHEET No.	ISSUE
NTS	05 April 17		CWS		R 501 - 14	01	

PLOT DATE 18/10/2018

150

100

50

40

30

20

10

A3 ORIGINAL SIZE

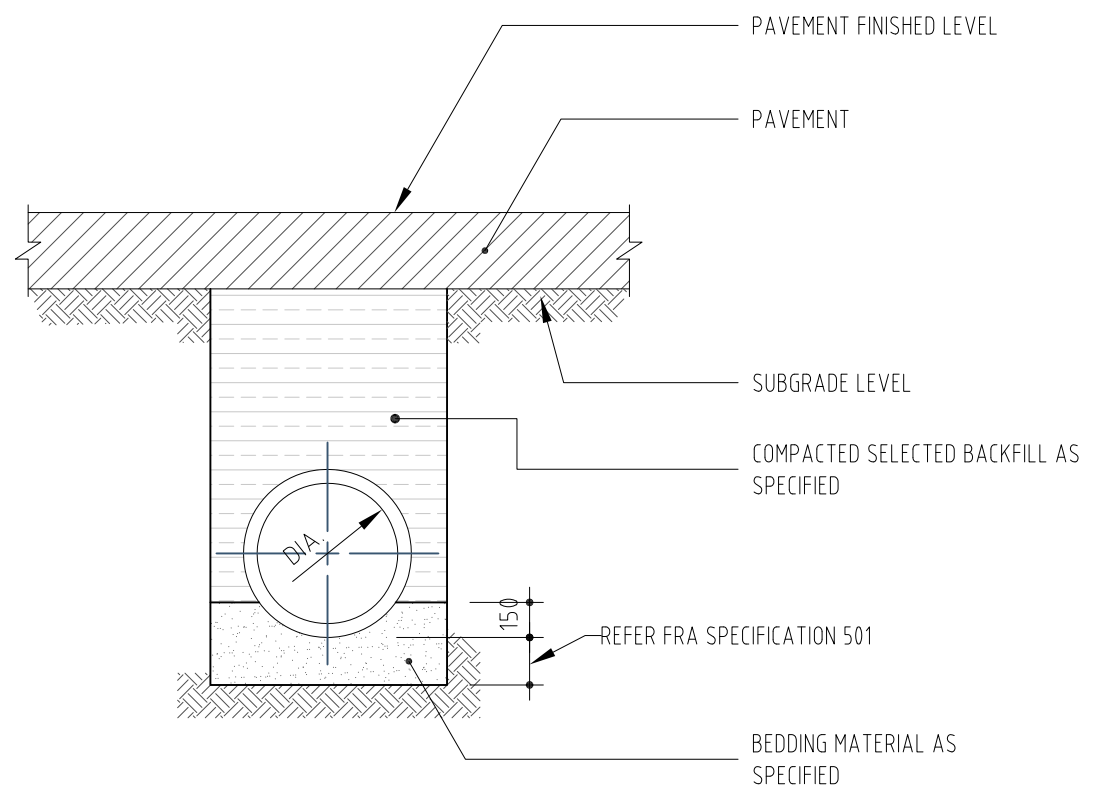

TRENCH CONDITION - UNDER PAVEMENT

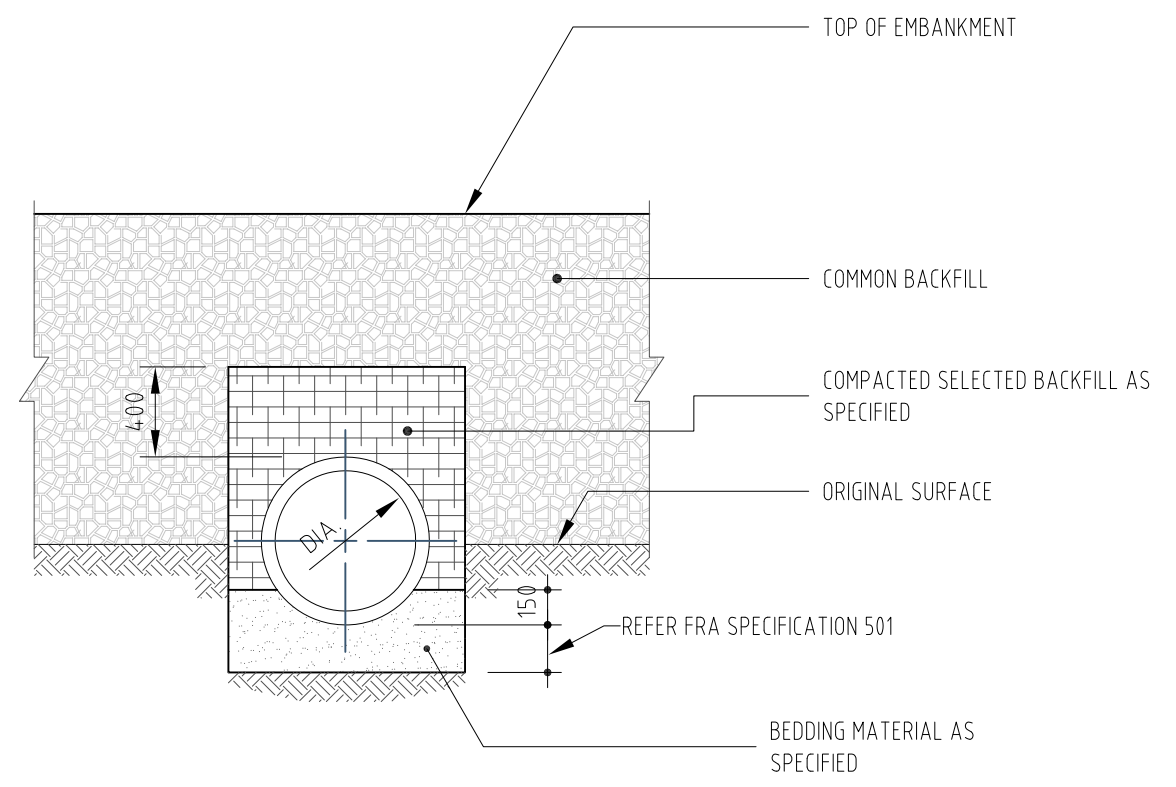

EMBANKMENT CONDITION

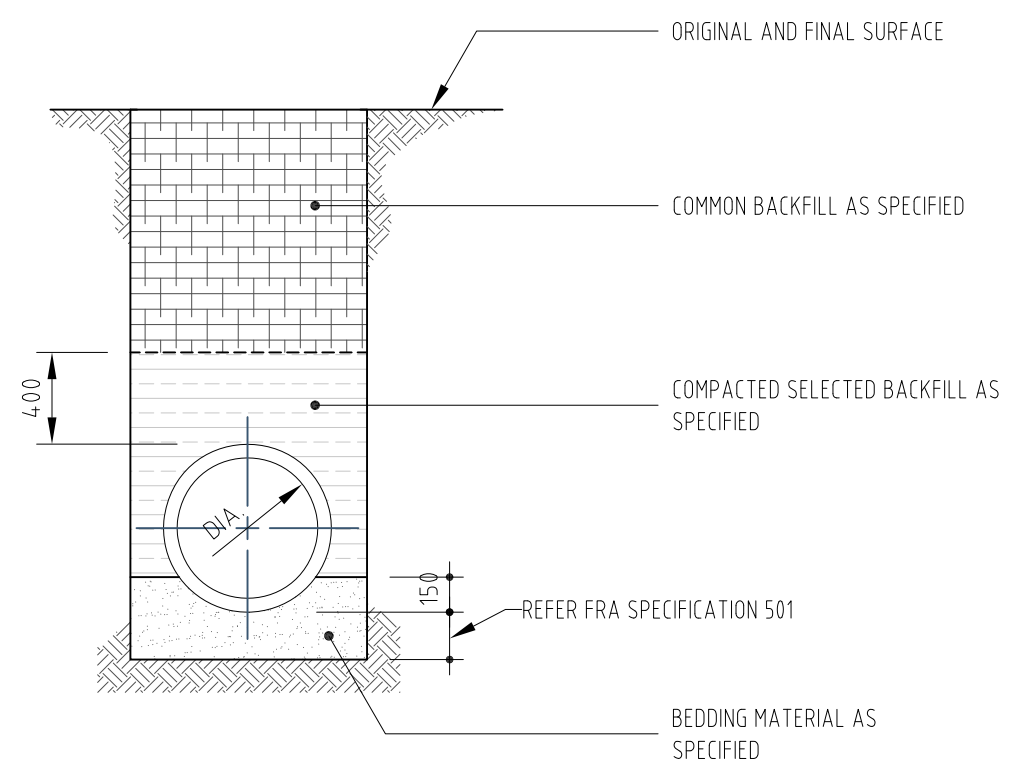

TRENCH CONDITION - OTHER THAN UNDER PAVEMENTS

NOTE:  
 1. FOR MATERIAL & COMPACTION STANDARDS REFER FRA SPECIFICATION 501.  
 2. FOR BEDDING DEPTHS AND TRENCH WIDTHS REFER FRA SPECIFICATION 501.

ISSUE	APPD	DATE	AMENDMENT	BY
E				
D				
C				
B				
A				

GENERAL NOTES

**STANDARD DRAWINGS**  
**CONCRETE PIPES UNDER EMBANKMENT ON EARTH & ROCK**

SCALE	DATE 05 April 17	DESIGN BY	DRAWN BY CWS	APPROVED	DRAWING No. R 501 - 15	SHEET No. 01	ISSUE
-------	---------------------	-----------	-----------------	----------	---------------------------	-----------------	-------



**Fiji Roads Authority**

TYPE: A

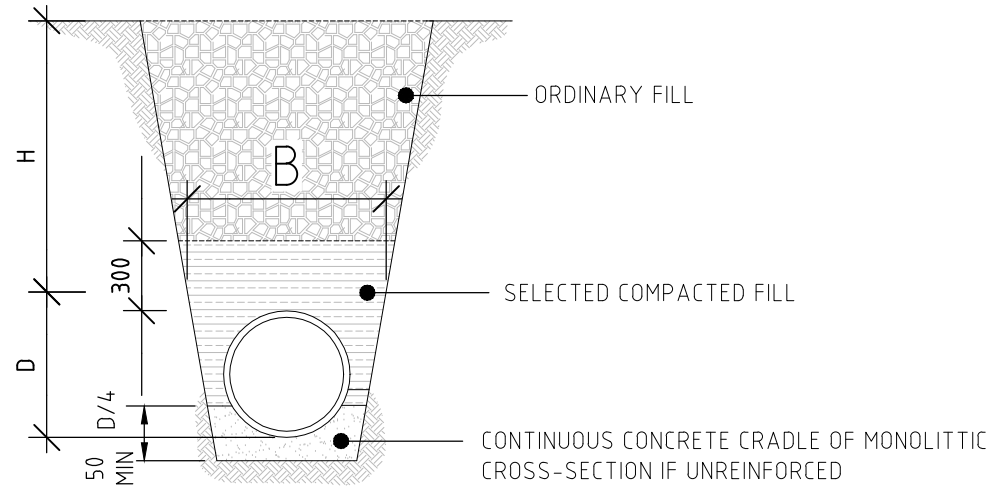

TYPE: C

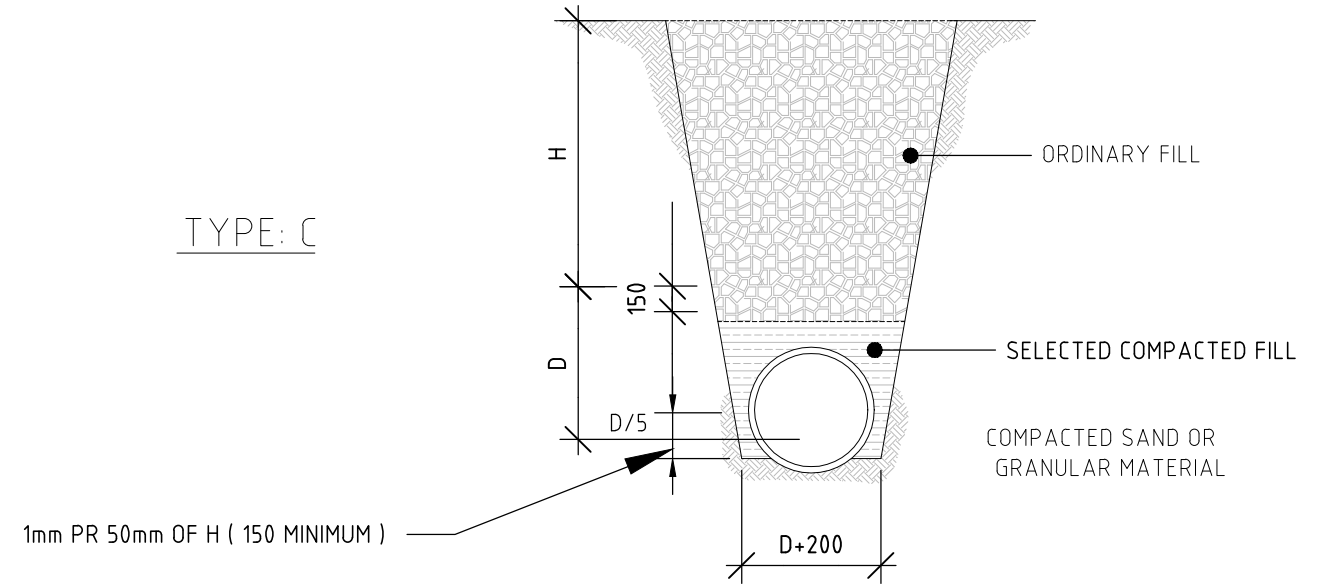

TYPE: B

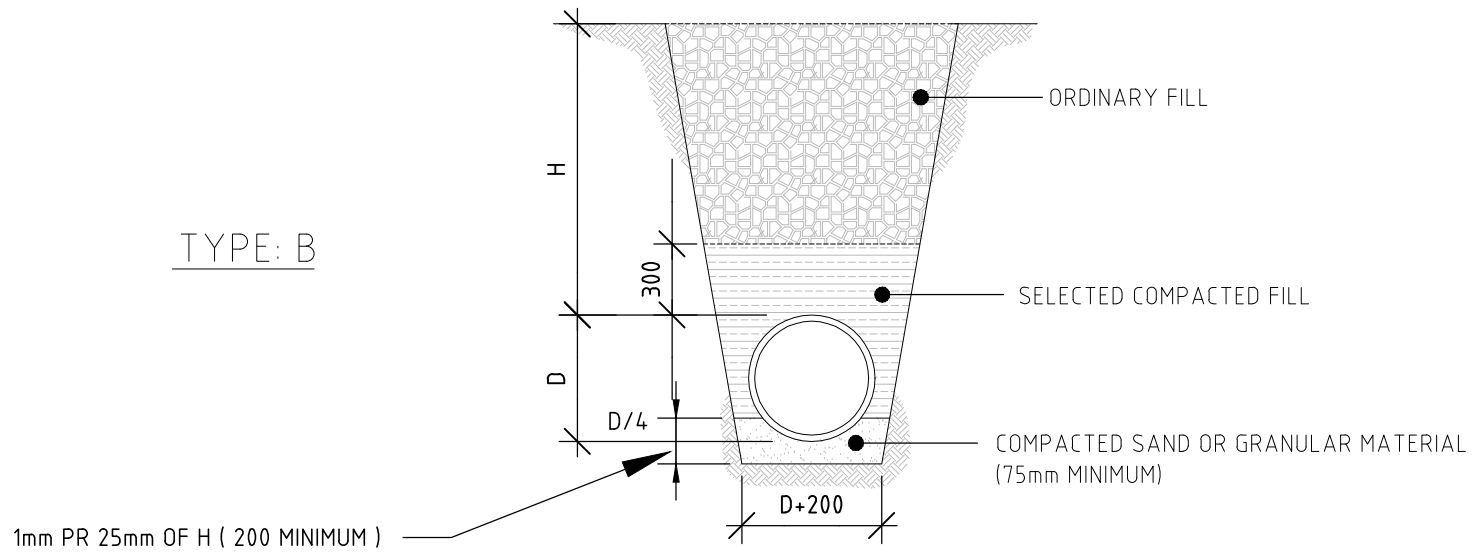

TYPE: D

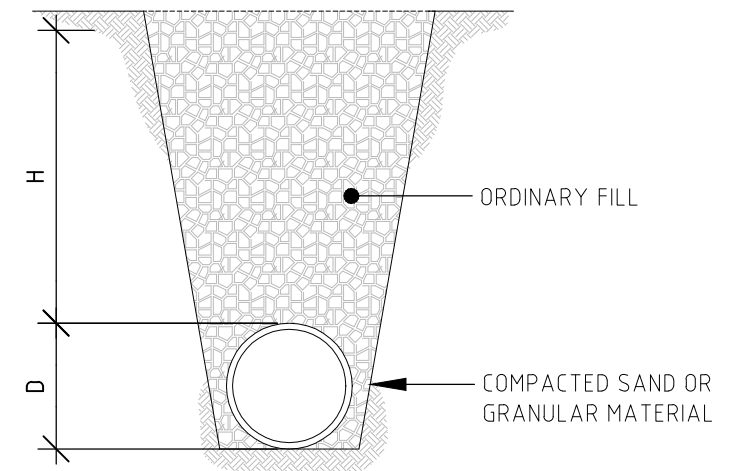

**NOTE:**  
1. FOR MATERIAL & COMPACTION STANDARDS REFER FRA SPECIFICATION 501.

GENERAL NOTES

1. Batter sloped for trenching based on depth and shoring shall be subject to Fiji trenching regulations.

STANDARD DRAWINGS  
CONCRETE PIPES IN TRENCH  
TYPES OF BEDDING ON EARTH



E					
D					
C					
B					
A					
ISSUE	APP'D	DATE	AMENDMENT	BY	

SCALE	DATE	DESIGN BY	DRAWN BY	APPROVED	DRAWING No.	SHEET No.	ISSUE
	01 MAY 17		CWS	A KETENILAGI	R 501 - 16	01	A

A3 ORIGINAL SIZE

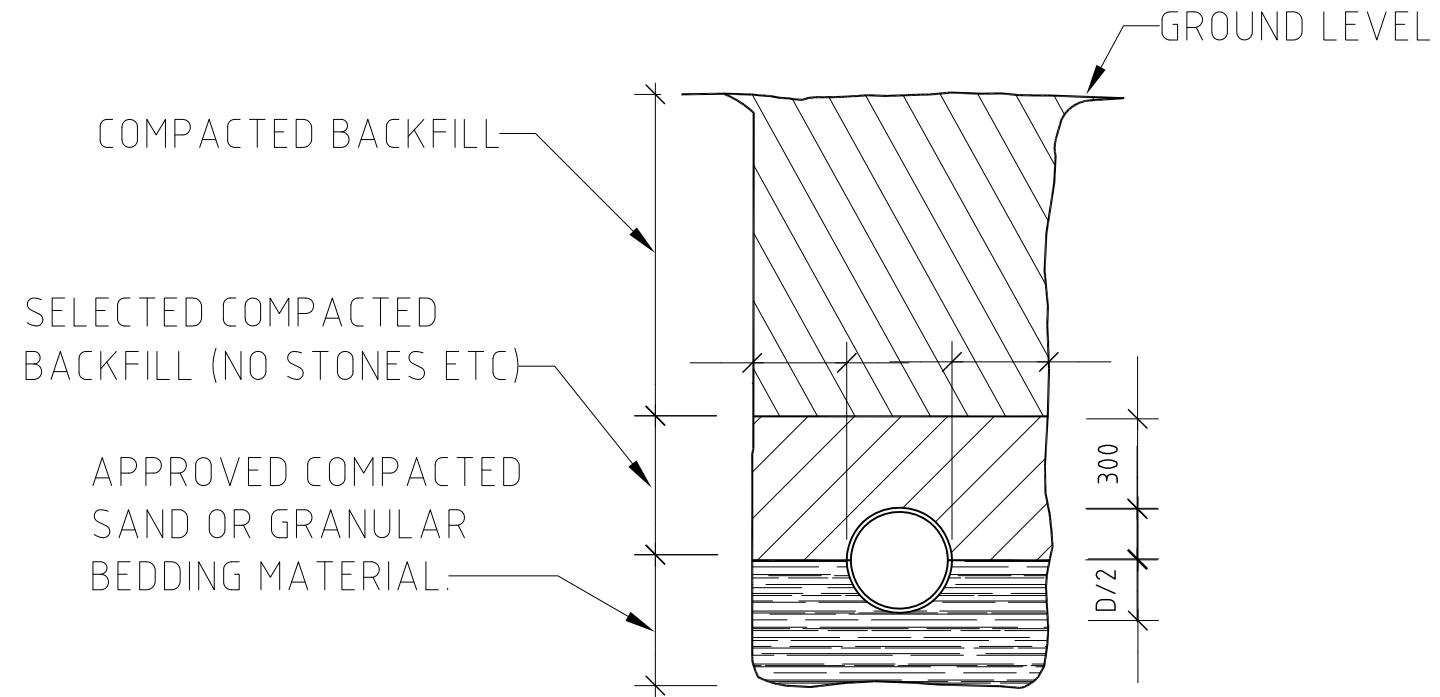

**NOTE:**

1. FOR MATERIAL & COMPACTION STANDARDS REFER FRA SPECIFICATION 501.
2. FOR BEDDING DEPTHS AND TRENCH WIDTHS REFER FRA SPECIFICATION 501.

**NOTE :**

ALL DIMENSIONS IN MILLIMETERS UNLESS OTHERWISE STATED,

A3 ORIGINAL SIZE

E			
D			
C			
B			
A			
ISSUE	APPD	DATE	AMENDMENT
			BY

GENERAL NOTES

<b>STANDARD DRAWINGS</b>		
<b>PIPE TRENCHES STANDARD DETAILS</b>		
SCALE	DATE	DESIGN BY
	02 MAY 17	

		<b>Fiji Roads Authority</b>		
DRAWN BY	APPROVED	DRAWING No.	SHEET No.	ISSUE
CWS	A KETENILAGI	R 501 - 17	01	A

# INDEX SHEET

## SERIES 502 SUB SURFACE DRAINAGE

DRAWING NUMBER	DRAWING TITLE
R 502 - 1	SUBSURFACE DRAIN TYPES
R 502 - 2	SUBSURFACE DRAIN PITS
R 502 - 3	TYPICAL SUB SURFACE DRAIN DETAIL PRECAST KERBS
R 502 - 4	TYPICAL SUB SURFACE DRAIN DETAIL CAST IN PLACE KERBS
R 502 - 5	PAVEMENT DETAILS AT V DRAINS.

---

PLOT DATE 12/03/2019

150

100

50

40

30

20

10

A3 ORIGINAL SIZE

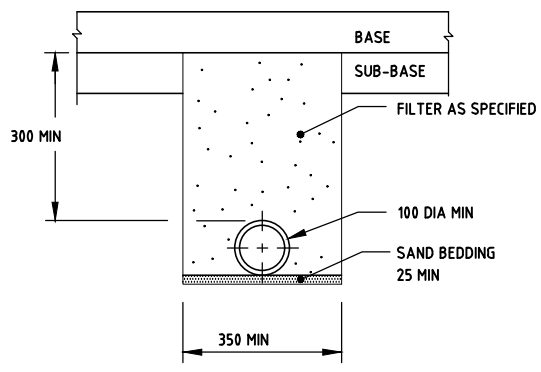

PAVEMENT DRAIN TYPE 1

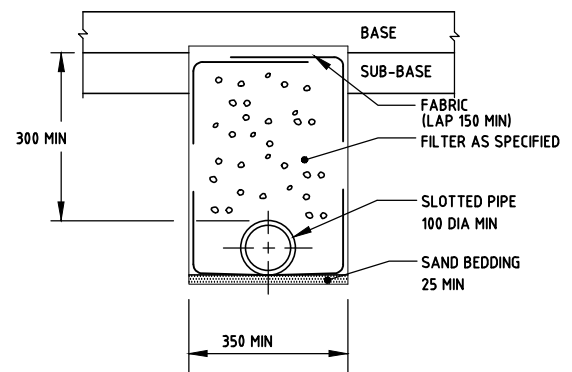

PAVEMENT DRAIN TYPE 2

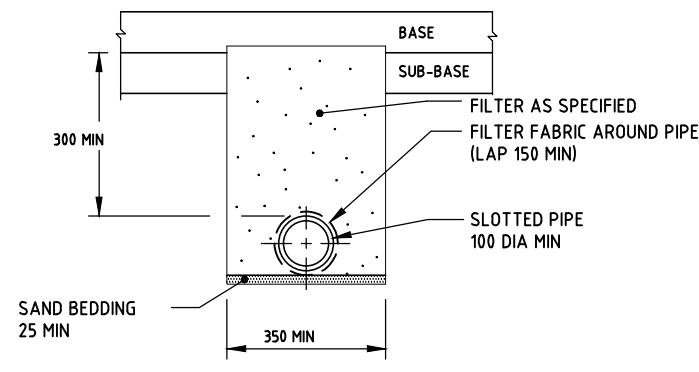

PAVEMENT DRAIN TYPE 3

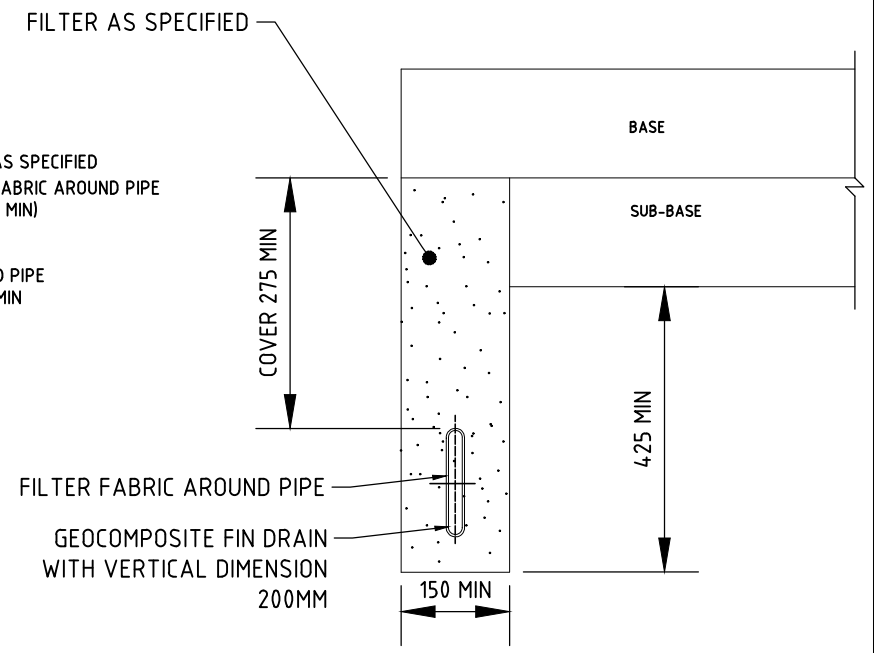

PAVEMENT DRAIN TYPE 4

(SEE NOTE 6)

SUBSURFACE PAVEMENT DRAINS PLACED BENEATH PAVEMENTS:

- a. SUBSURFACE PAVEMENT DRAINS PLACED IMMEDIATELY UNDER OR WITHIN THE THE TRAFFICKED PAVEMENT SHALL BE A TYPE 2 SUBSURFACE PAVEMENT DRAIN WITH A GRADE B4 NO-FINES CONCRETE FILTER MATERIAL.
- b. IF A TYPE 4 SUBSURFACE PAVEMENT DRAIN IS USED IN LIEU OF A TYPE 2 DRAIN. GRADE A1, A2 OR A3 FILTER SAND SHALL BE USED UP TO A LEVEL OF 50mm ABOVE THE TOP OF THE GEOCOMPOSITE DRAIN. FILTER SAND SHALL BE WATERED IN BY FULLY SATURATING THE MATERIAL AFTER PLACEMENT TO ENSURE THAT IT COMPLETELY SURROUNDS THE DRAIN.

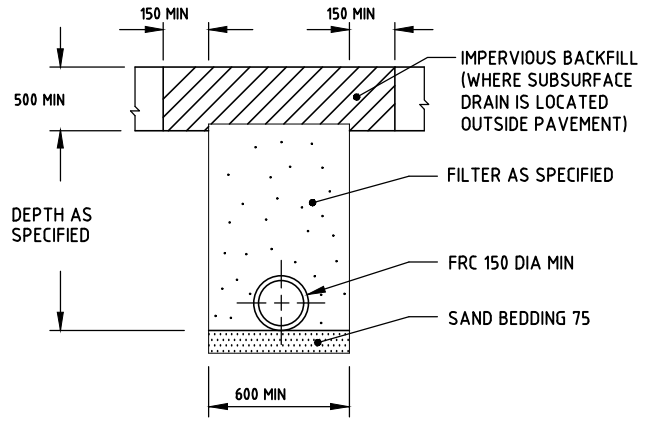

FORMATION DRAIN

SELECTION OF TYPE OF SUBSURFACE DRAIN & FILTER TYPE			
SUB-GRADE TYPE	PERMIABILITY RANGE m/sec	TYPES OF PAVEMENT DRAIN	GRADE OF GRANULAR FILTER MATERIAL
HOMOGENOUS CLAY WITH VERY LOW PERMIABILITY.	$< 10^{-9}$	TYPE 3, TYPE 4	SAND (GRAD A2 OR A3)
SILTY OR SANDY CLAYS AND STRATIFIED CLAYS WITH MODERATELY LOW PERMEABILITY.	$10^{-9}$ to $10^{-5}$	TYPE 2, TYPE 3 OR TYPE 4	SAND (GRAD A4 OR A6)
CLEAN SAND OR GRAVEL WITH HIGH PERMEABILITY.	$> 10^{-5}$	TYPE 1 OR TYPE 2	AGGREGATE(GRAD B1 OR B2)
SOLID ROCK OR CLEAN BROKEN ROCK WITH HIGH PERMEABILITY OR PERMEABLE FISSURES	NOT APPLICABLE	TYPE 1	AGGREGATE(GRAD B3 OR B4)

NOTES:

1. FABRIC, FILTER MATERIAL AND PIPE CATEGORY SHALL BE AS SPECIFIED IN FIJI ROADS AUTHORITY, ROAD WORKS STANDARDS AND SPECIFICATIONS - STANDARD SECTION (SS) 502.
2. LEVEL TRENCH BOTTOM SHALL BE WITH IMPERMEABLE MATERIAL TO REMOVE IRREGULARITIES.
3. IF SUB-BASE IS NOT PLACED IMMEDIATELY, A 50mm CAP OF PERMEABLE SUB-BASE MATERIAL SHALL BE LAID ON THE FILTER MATERIAL AND COMPACTED.
4. SUBSURFACE DRAINS BENEATH OR WITHIN 1m OF THE ROAD SHALL BE SHALL BE 1000kN/m/m CORRUGATED PERFORATED PLASTIC PIPE, FRC OR CONCRETE PIPE UNLESS SPECIFIED OTHERWISE.
5. GEOCOMPOSITE FIN DRAIN MAY BE PLACED ON ONE SIDE OF THE TRENCH LOCATED WITHIN THE PAVEMENT LAYERS ON IN GRANULAR SU-BGRADE.
6. SSD's, PITS AND FLUSHOUT RISERS SHALL BE INSTALLED IN ACCORDANCE WITH STANDARD SPECIFICATION SECTION 502

E					
D					
C					
B					
A					
ISSUE	APP'D	DATE	AMENDMENT	BY	GENERAL NOTES

STANDARD DRAWINGS					
TYPICAL DETAILS					
SUBSURFACE DRAIN TYPES					
SCALE	DATE	DESIGN BY	DRAWN BY	APPROVED	DRAWING No.
	05 April 17		CWS		R 502 - 1
					SHEET No.
					01
					ISSUE

PLOT DATE 12/03/2019

150  
100  
50  
40  
30  
20  
10

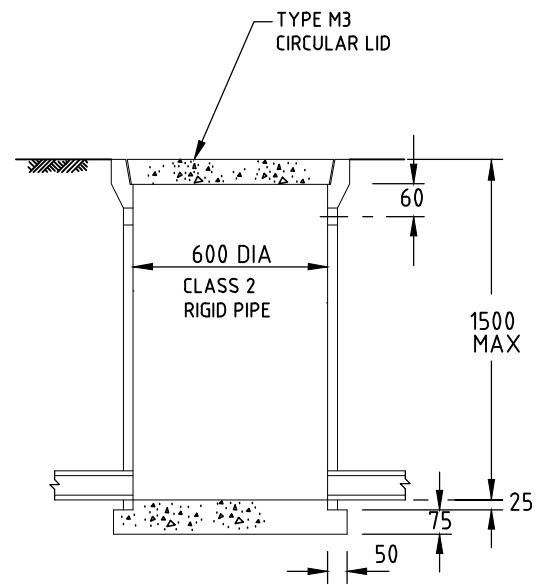

TYPE S1  
(CONCRETE COVER)

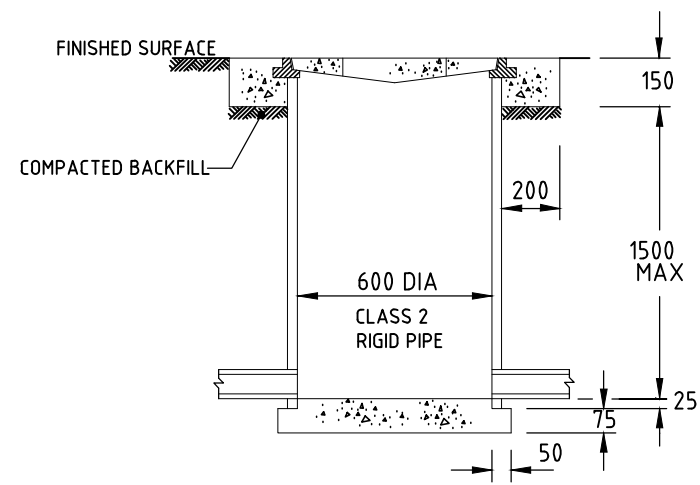

TYPE S2  
(CAST IRON COVER)

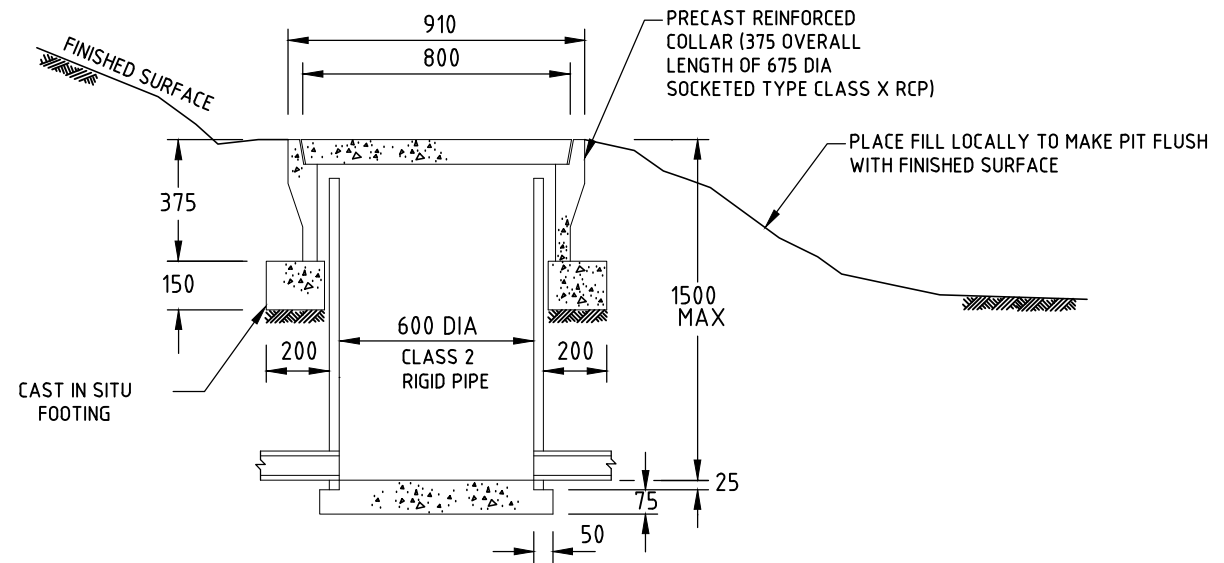

TYPE S3  
(CONCRETE COVER)

SUBSURFACE DRAINAGE PITS

NOTES:

- DRAINAGE PITS ARE CONSIDERED TO BE RESTRICTED ACCESS LOCATIONS FOR CONSTRUCTION AND MAINTENANCE PURPOSES. FRA HAS DETERMINED THAT THE DRAINAGE PITS MEET THE FIRST THREE CONFINED SPACE CRITERIA. (ENCLOSED/PARTLY ENCLOSED) LIKELY TO BE ENTERED AT NORMAL ATMOSPHERIC PRESSURE (LIMITED OR RESTRICTED ENTRY OR EXIT) DESIGNERS SHALL LIAISE WITH FRA TO ACCEPT THIS DETERMINATION.
- THESE PITS ARE NOT SUITABLE FOR USE IN OR WITHIN 300 mm OF THE TRAFFIC LANES.
- CAST IRON COVERS SHALL BE CAPABLE OF SUPPORTING WITHOUT STRUCTURAL FAILURE THE CLASS C MINIMUM ULTIMATE LIMIT STATE DESIGN LOAD SPECIFIED IN AS 3996, PRECAST CONCRETE LIDS SHALL BE CAPABLE OF SUPPORTING A TEST LOAD OF 60KN. ALTERNATE MATERIALS MAYBE CONSIDERED HOWEVER THEY NEED TO BE APPROVED AND MEET REQUIREMENTS OF AS 3996.
- WHERE SUBSURFACE PITS HAVE TO BE LOCATED IN TRAFFICKED AREAS JUNCTION PITS SHALL BE USED WITH HEAVY DUTY COVERS.
- JUNCTION PITS OR SIDE ENTRY PITS SHALL BE USED WHERE DEPTHS EXCEED 1500mm.
- ALL LIDS SHALL HAVE WEIGHT AND CAPACITY IMPRINTS. THESE PITS ARE NOT SUITABLE FOR USE IN OR WITHIN 300 mm OF THE TRAFFIC LANES.
- ALL LIDS SHALL FIT FLUSH AND HAVE PROVISION FOR LIFTING. CONCRETE LIDS SHALL HAVE TWO LIFTING HOLES OF 25 X 50 MIN.
- PITS ARE REQUIRED TO SUPPORT HYDROSTATIC PRESSURE, COMPACTION PRESSURE OF 25kpa AND A VERTICAL LOAD OF 150Kpa AND A VERTICAL LOAD OF 150KN APPLIED EITHER ON THE COVER OR THE PAVEMENT ADJACENT TO THE PIT.
- ALL BASE SLABS ARE CAST INSITU.
- CONCRETE FOR PRECAST CONCRETE LIDS SHALL BE GRADE N40 OR HIGHER COMPLYING WITH FRA SPECIFICATION. CAST-IN-SITU CONCRETE SHALL BE NORMAL - CLASS N25 STANDARD STRENGTH GRADE OR HIGHER COMPLYING WITH THE REQUIREMENTS OF AS 1379 EXPOSURE CLASSIFICATIONS UP TO AND INCLUDING A2.
- STEEL REINFORCEMENT SHALL COMPLY WITH FRA SPECIFICATION.

A3 ORIGINAL SIZE

E				
D				
C				
B				
A				
ISSUE	APPD	DATE	AMENDMENT	BY

GENERAL NOTES  
 1. AS 3996 ACCESS COVERS & GRATES  
 2. AS 3600 CONCRETE STRUCTURES  
 3. ALL DIMENSIONS ARE IN MILLIMETERS  
 4. REFER STANDARD SPECIFICATION SECTION 502 FOR INSTALLATION AND SPACING REQUIREMENTS

SCALE		DATE 05 April 17		DESIGN BY		DRAWN BY CWS		APPROVED		DRAWING No. R 502 - 2		SHEET No. 01		ISSUE	

Fiji Roads Authority

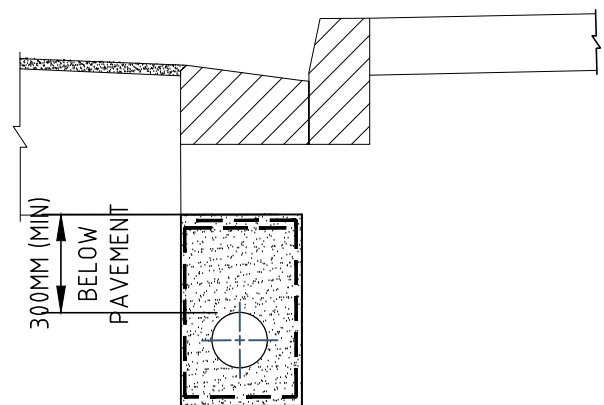

SUBSOIL DRAIN DETAIL - BELOW PAVEMENT

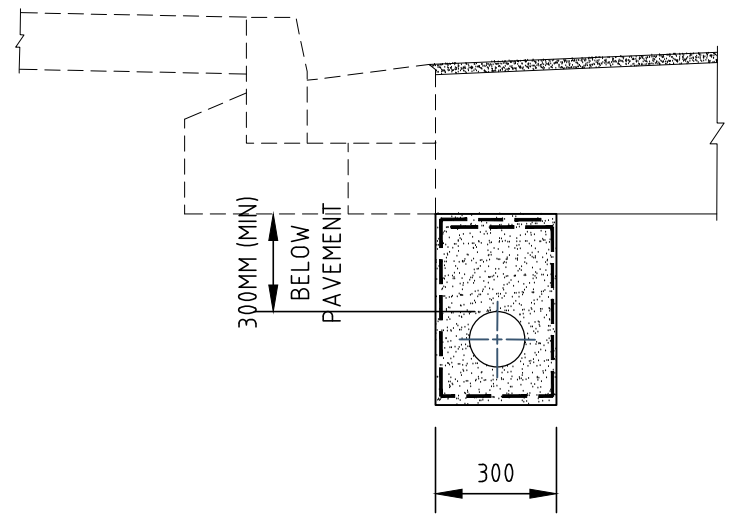

SUBSOIL DRAIN DETAIL - EXISTING KERB AND CHANNEL

NOTES:

REFER DRAWING No. 502 - 1 FOR SSD DETAILS REGARDING, FILTER MATERIAL, GEOFABRIC AND PIPE.

A3 ORIGINAL SIZE	E				
	D				
	C				
	B				
	A				
ISSUE	APP'D	DATE	AMENDMENT	BY	

GENERAL NOTES  
 1. SSD's, DRAINAGE PITS AND FLUSHOUT RISERS SHALL BE INSTALLED IN ACCORDANCE WITH STANDARD SPECIFICATION SECTION 502

<b>STANDARD DRAWINGS</b>		
<b>TYPICAL SUBSURFACE DRAINAGE DETAIL PRECAST KERBS</b>		
SCALE	DATE 05 April 17	DESIGN BY

 <b>Fiji Roads Authority</b>				
DRAWN BY CWS	APPROVED	DRAWING No. R 502 - 3	SHEET No. 01	ISSUE

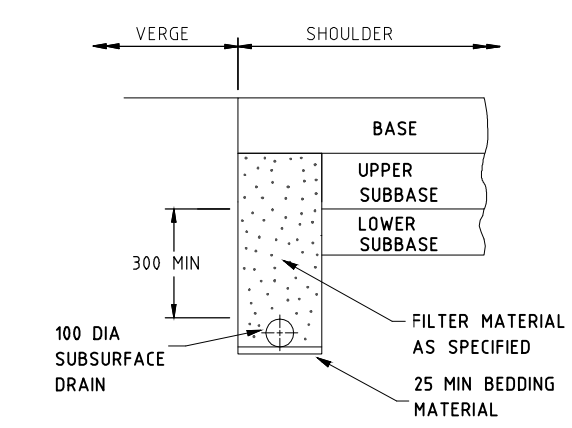

UNDER FULL WIDTH FULL DEPTH PAVEMENT

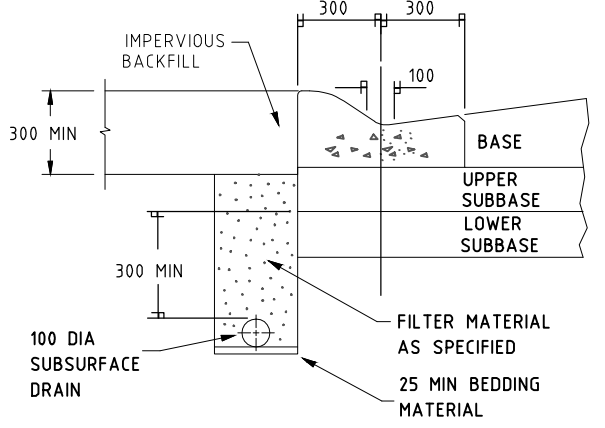

BEHIND KERB & CHANNEL ON NEW ROADS

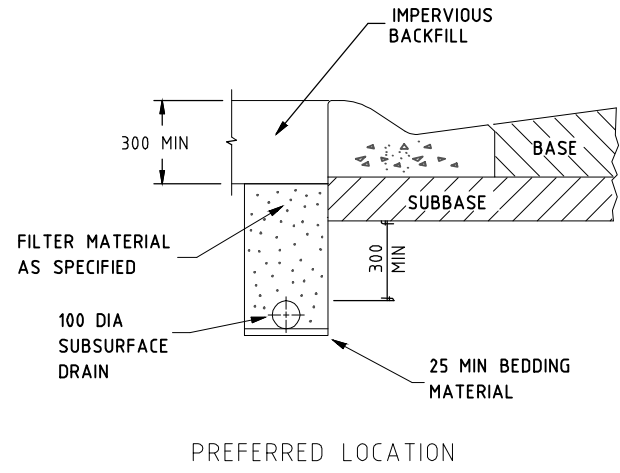

PREFERRED LOCATION

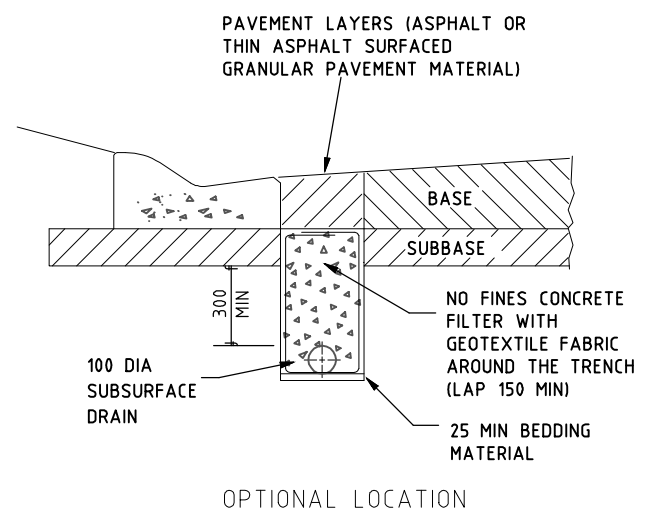

OPTIONAL LOCATION

ADJACENT TO KERB & CHANNEL ON EXISTING ROADS

LONGITUDINAL PAVEMENT DRAINS.

GENERAL NOTES  
1. SSD's, DRAINAGE PITS AND FLUSHOUT RISERS SHALL BE INSTALLED IN ACCORDANCE WITH STANDARD SPECIFICATION SECTION 502

STANDARD DRAWINGS  
TYPICAL SUBSURFACE DRAINAGE DETAIL  
CAST IN PLACE KERBS



E					
D					
C					
B					
A					
ISSUE	APP'D	DATE	AMENDMENT	BY	

SCALE	DATE	DESIGN BY	DRAWN BY	APPROVED	DRAWING No.	SHEET No.	ISSUE
	05 April 17		CWS		R 502 - 4	01	

PLOT DATE 18/10/2018

150

100

50

40

30

20

10

A3 ORIGINAL SIZE

E				
D				
C				
B				
A				
ISSUE	APPD	DATE	AMENDMENT	BY

GENERAL NOTES

STANDARD DRAWINGS		
PAVEMENT DETAIL AT V DRAIN		
SCALE	DATE	DESIGN BY
	05 April 17	



**Fiji Roads Authority**

DRAWN BY	APPROVED	DRAWING No.	SHEET No.	ISSUE
CWS		R 502 - 5	01	

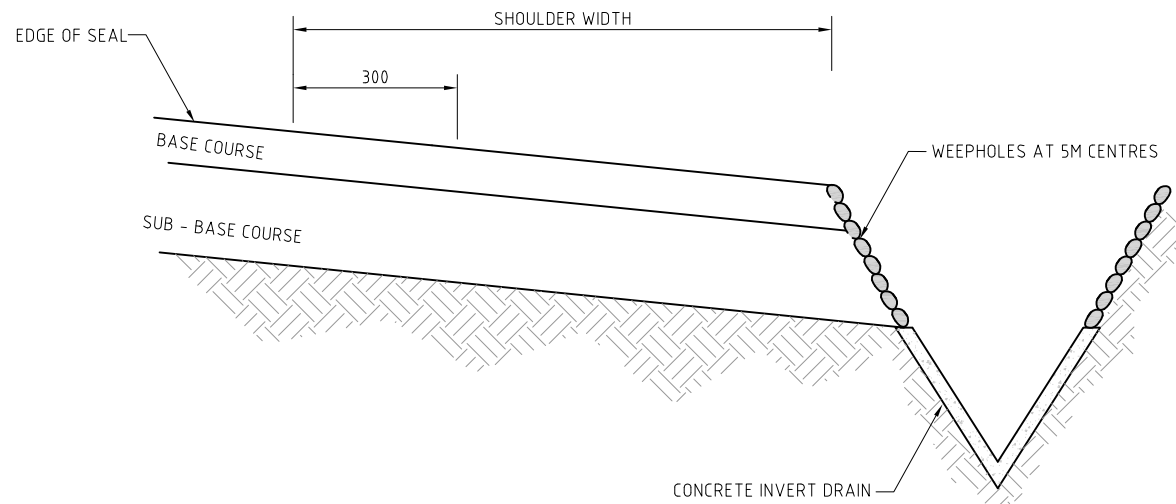

PAVEMENT DETAIL AT V DRAIN

# INDEX SHEET

## SERIES 503      STORMWATER PITS & MANHOLES

DRAWING NUMBER	DRAWING TITLE
R 503 - 1	SIDE ENTRY DETAILS
R 503 - 2	SAG PITS DETAILS
R 503 - 3	STORMWATER MANHOLE DETAILS
R 503 - 4	STORMWATER MANHOLE DETAILS
R 503 - 5	JUNCTION PIT – CONCRETE COVER
R 503 - 6	JUNCTION PIT – CAST IRON COVER

PLOT DATE 18/10/2018

150  
100  
50  
40  
30  
20  
10

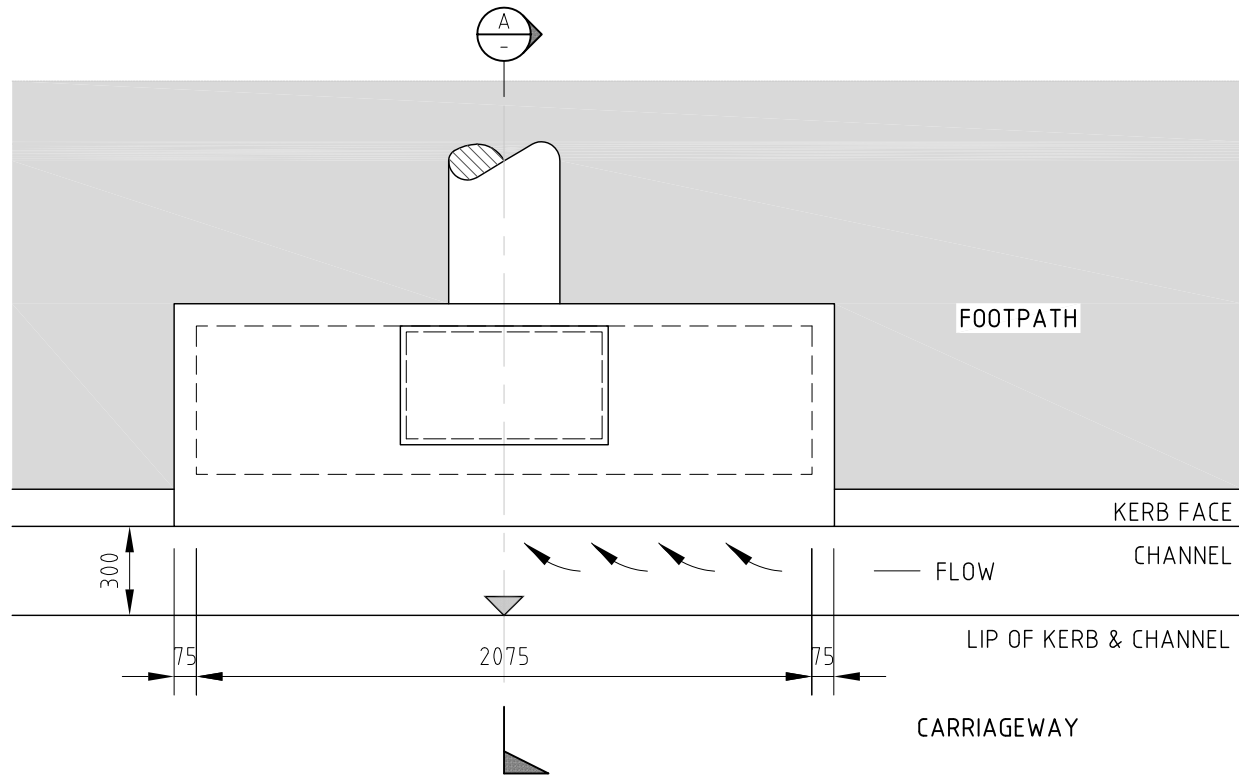

PLAN - PRECAST SIDE ENTRY  
Scale 1:25

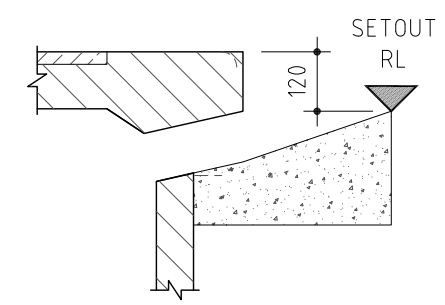

SIDE ENTRY PIT SETOUT POINT  
Scale 1:15

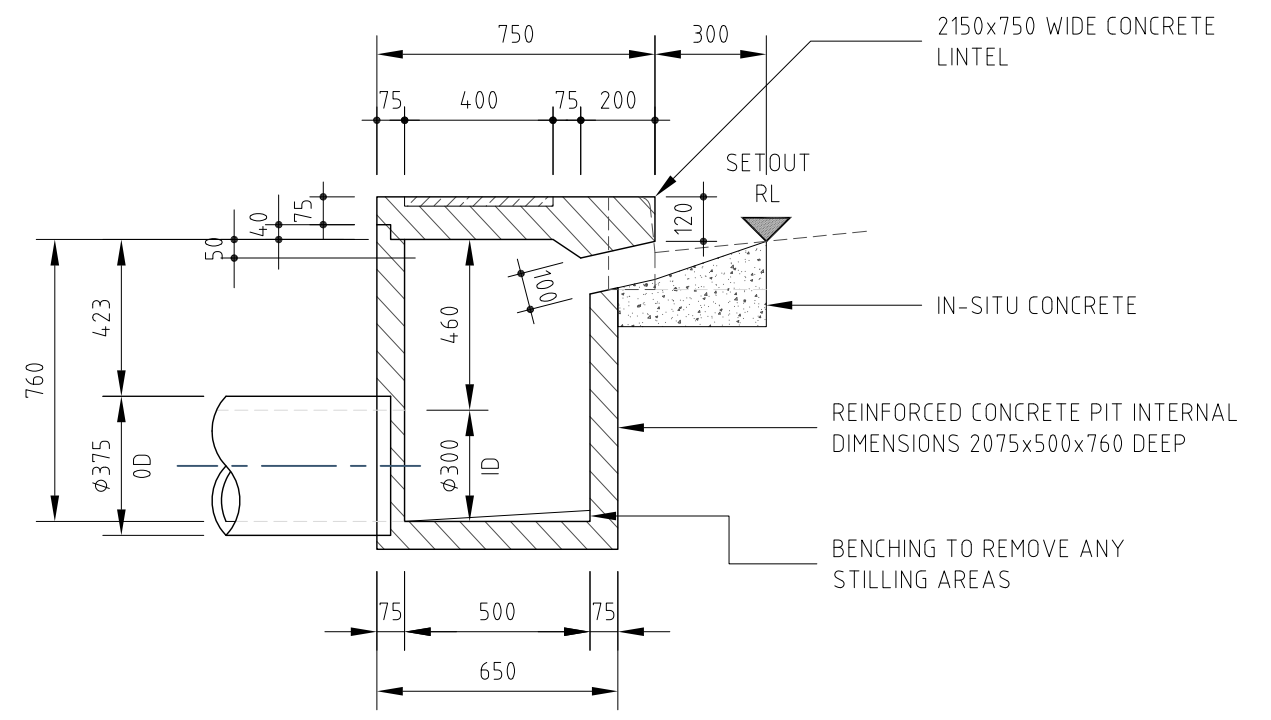

SECTION A-A  
SCALE 1:20  
NORMAL INSTALLATION

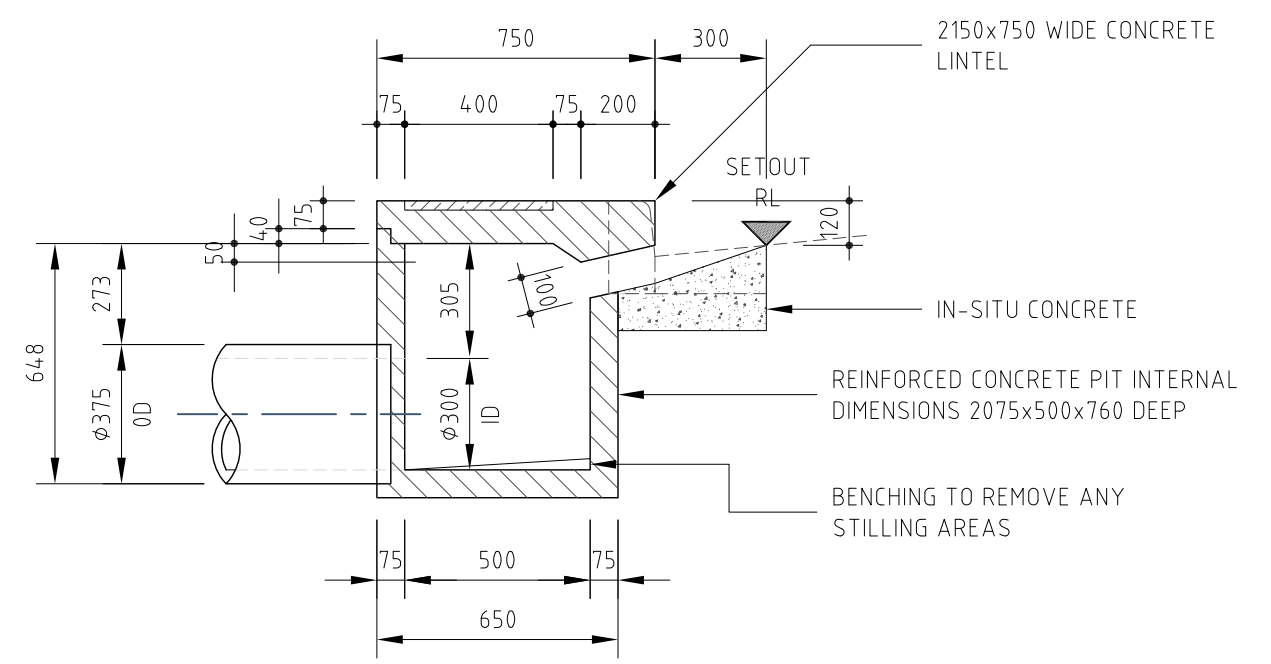

SECTION A-A  
SCALE 1:20  
SHALLOW INSTALLATION

E					
D					
C					
B					
A					
ISSUE	APPD	DATE	AMENDMENT	BY	

GENERAL NOTES

STANDARD DRAWINGS	
SIDE ENTRY PITS DETAIL	
SCALE	DATE
	05 April 17
DESIGN BY	DRAWN BY
	CWS

**Fiji Roads Authority**

APPROVED	DRAWING No.	SHEET No.	ISSUE
	R 503 - 1	01	

PLOT DATE 18/10/2018

150  
100  
50  
40  
30  
20  
10

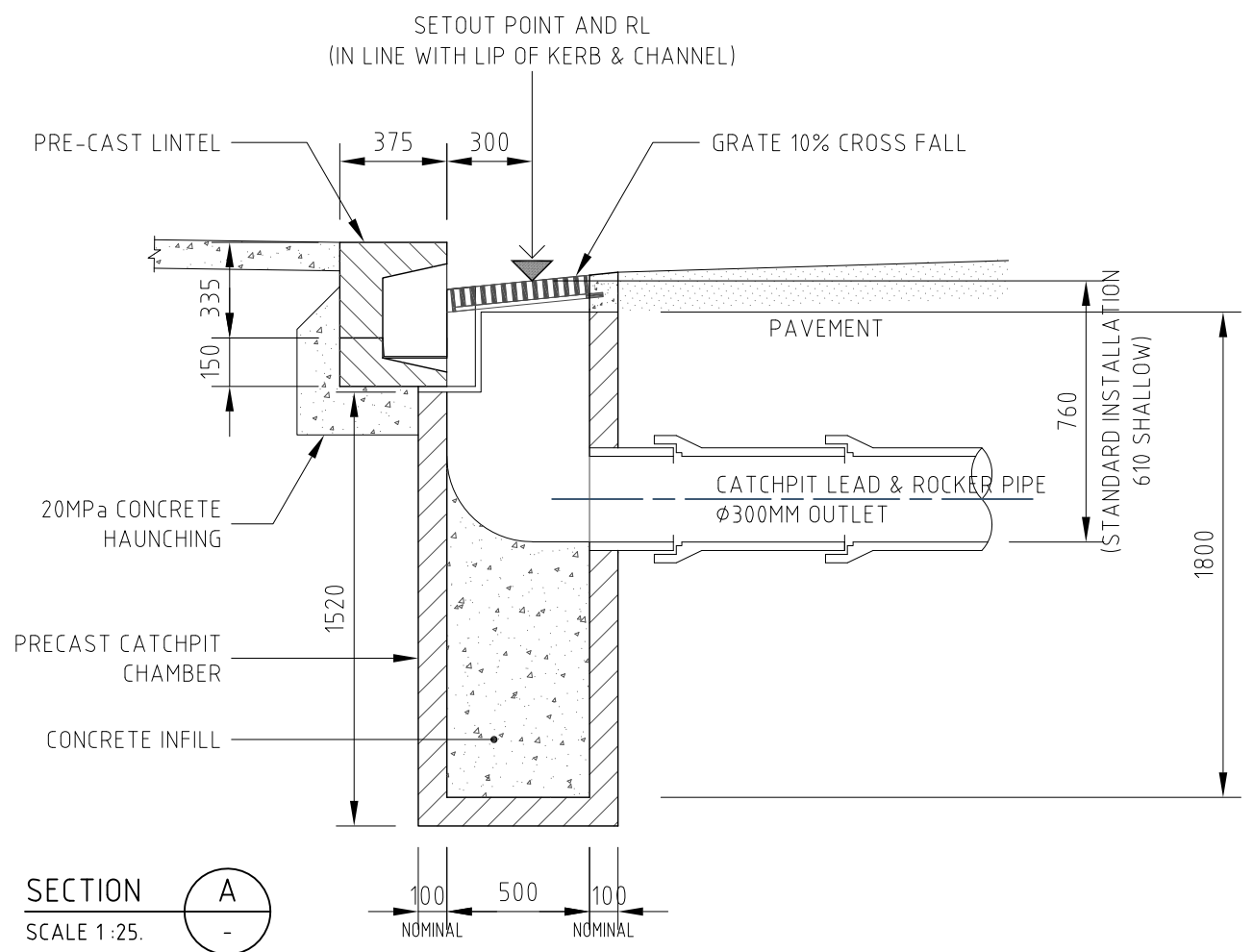
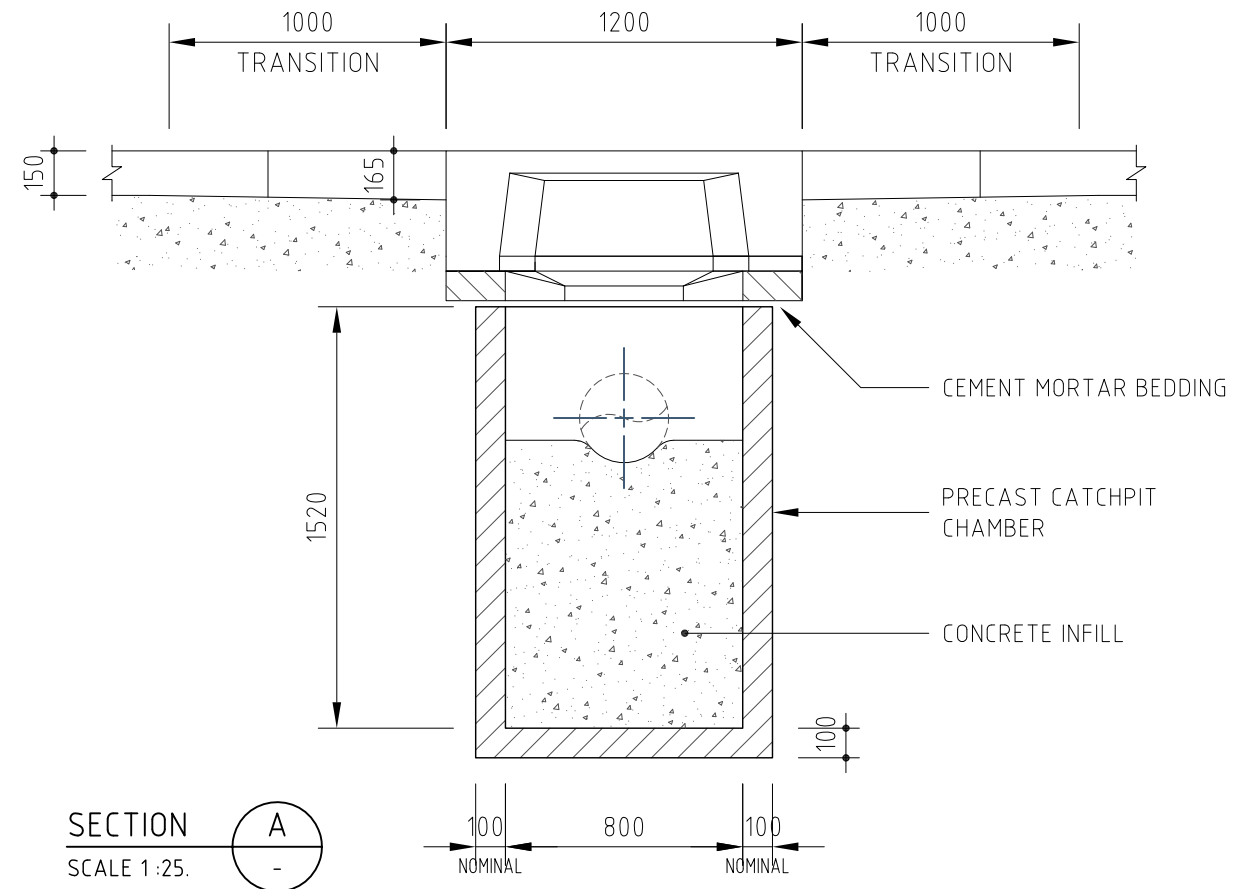
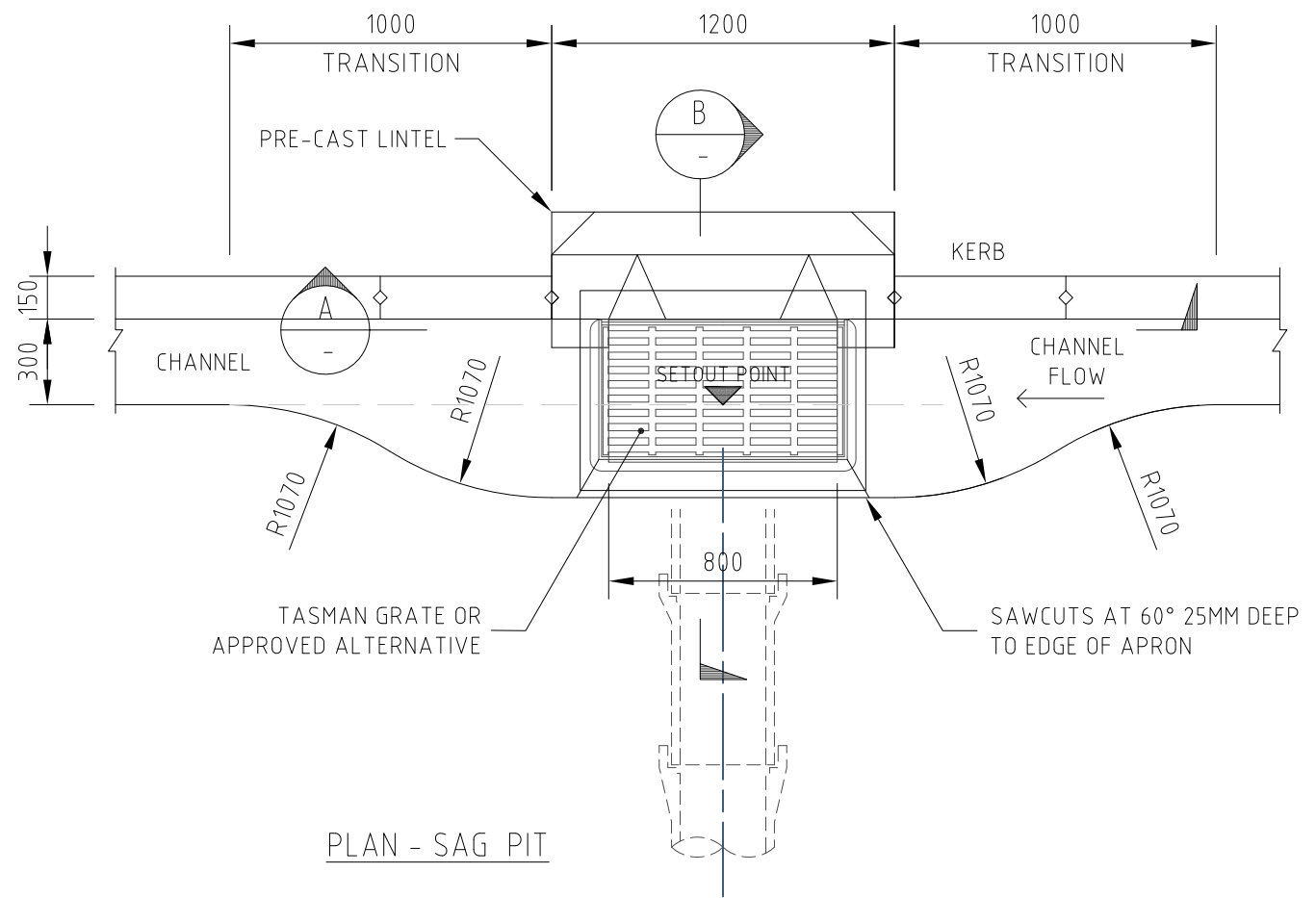

A3 ORIGINAL SIZE	E				
	D				
	C				
	B				
	A				
ISSUE	APP'D	DATE	AMENDMENT	BY	

GENERAL NOTES

STANDARD DRAWINGS				
SAG PIT DETAIL				
SCALE	DATE	DESIGN BY	DRAWN BY	APPROVED
	05 April 17		CWS	

Fiji Roads Authority

DRAWING No.	SHEET No.	ISSUE
R 503 - 2	01	

PLOT DATE 18/10/2018

150

100

50

40

30

20

10

A3 ORIGINAL SIZE

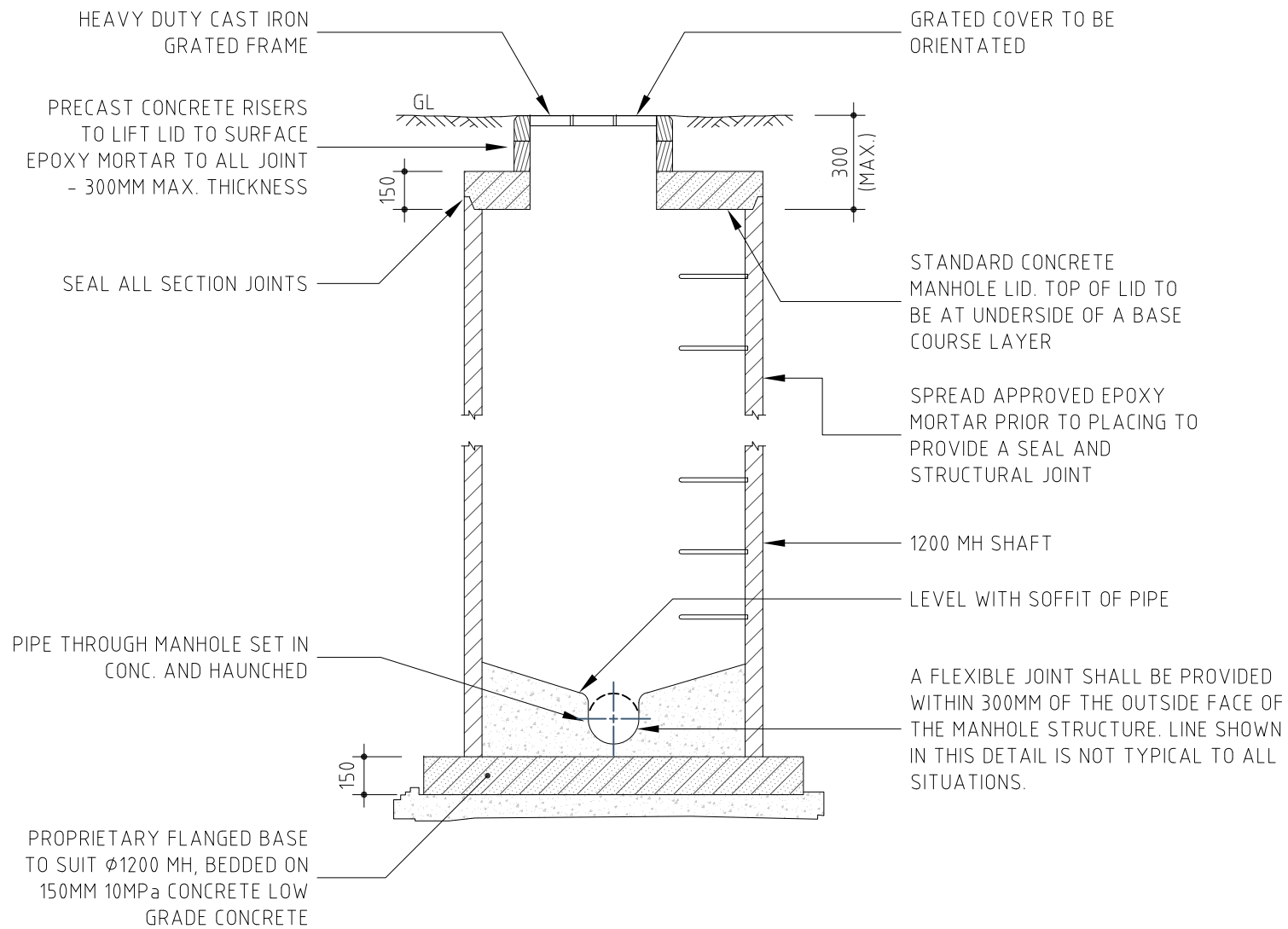

TYPICAL STORMWATER MANHOLE

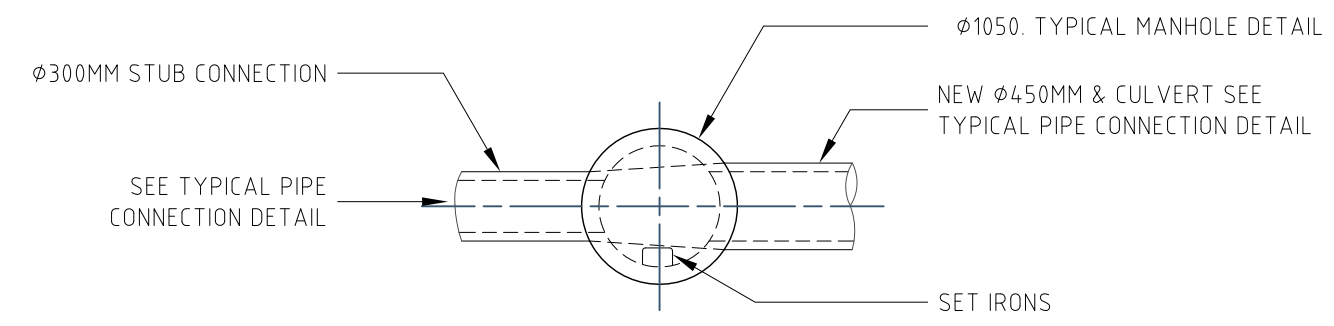

MANHOLE 1 SCHEMATIC LAYOUT  
Scale 1:50

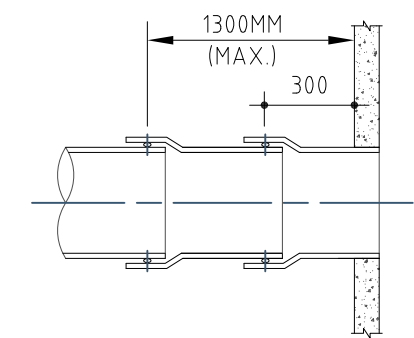

TYPICAL PIPE CONNECTION

NOTES:

- PRECAST UNITS MAY BE CONSTRUCTED TO THE MANUFACTURER'S DETAILS. THE DESIGN SHALL COMPLY WITH THE ASD5100 AND THE FOLLOWING ADDITIONAL REQUIREMENTS:
- COMBINED FACTORED LATERAL PRESSURE AT ANY POINT AT THE ULTIMATE UNIT STATE SHALL BE NOT LESS THAN 25 Kpa.
  - ADEQUATE DRAINAGE SHALL BE PROVIDED TO PIT WALLS TO AVOID HYDROSTATIC PRESSURE.
  - VERTICAL LOAD 210 KN APPLIED ANYWHERE ON PIT.
  - MINIMUM REINFORCEMENT AREA SHALL BE 150 mm<sup>2</sup>/m<sup>2</sup>.
  - CONCRETE SHALL BE 32MPH OR HIGHER, COMPLYING WITH THE REQUIREMENTS IF AS 1379 EXPOSURE CLASSIFICATIONS UP TO AND INCLUDING B1.
  - STEEL AND STEP IRONS SHALL BE STRUCTURAL GRADE 250 TO AS 3679 PART 1.

ISSUE	APP'D	DATE	AMENDMENT	BY
E				
D				
C				
B				
A				

GENERAL NOTES

STANDARD DRAWINGS			
STORMWATER MANHOLE DETAIL			
SCALE	DATE	DESIGN BY	DRAWN BY
	05 April 17		CWS

**Fiji Roads Authority**

APPROVED	DRAWING No.	SHEET No.	ISSUE
	R 503 - 3	01	

PLOT DATE 18/10/2018

150

100

50

40

30

20

10

A3 ORIGINAL SIZE

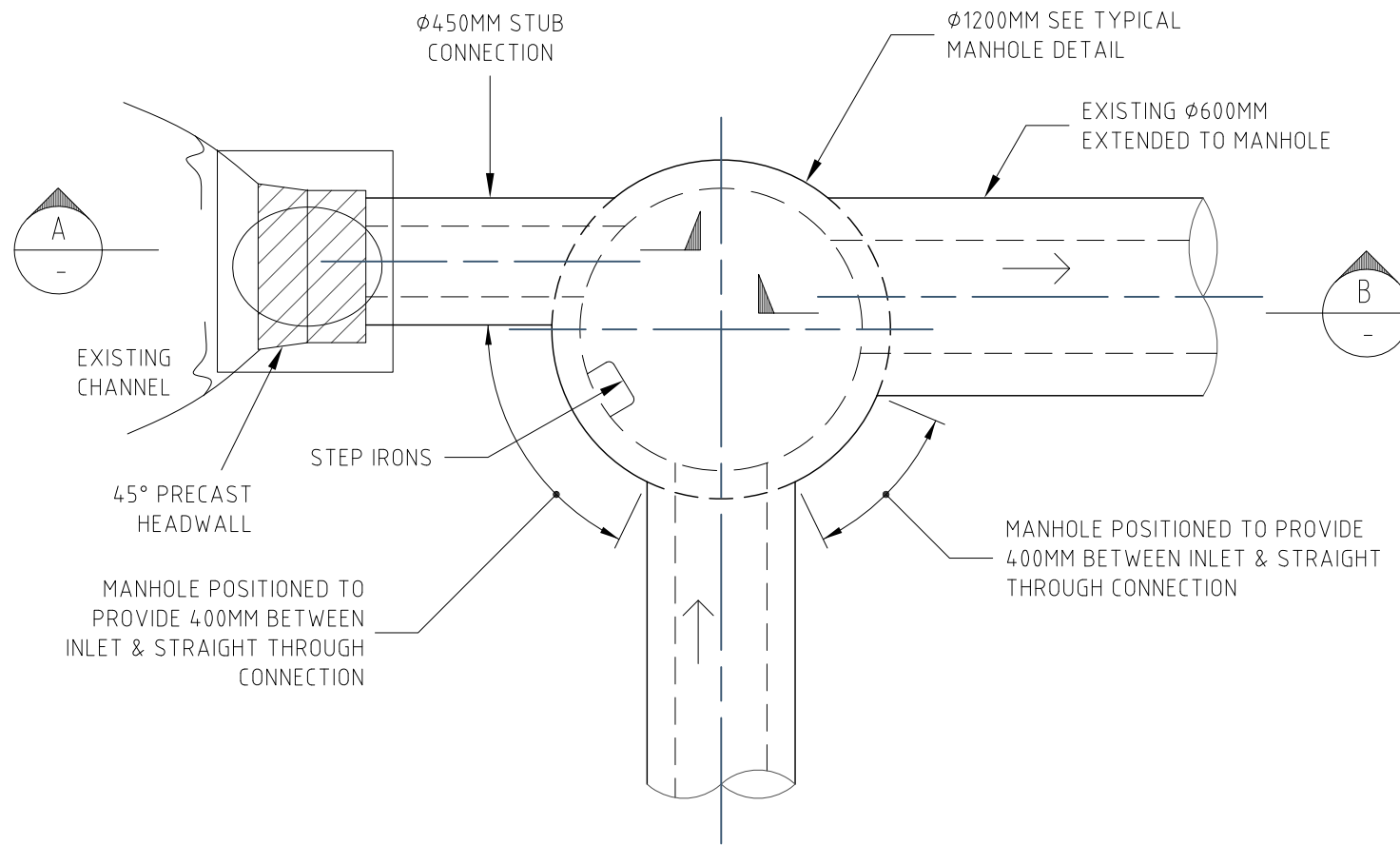

MANHOLE 2 - SCHEMATIC LAYOUT

Scale 1:25

**Notes**

1. MANHOLE SHALL BE PROVIDED WITH PURPOSE MADE PRECAST CONCRETE LIDS NOT LESS THAN 150MM THICK IN BEAMS OR 225MM THICK WHERE MANHOLES ARE LOCATED IN CARRIAGE WAYS.
2. MANHOLE SHALL BE SUPPLIED WITH PRECAST STEP RUNGS. RUNGS FOR MANHOLE SHALL BE OF THE TYPE AS DETAILED IN NZS 4404:2010 APPENDIX B, DRAWING CM 004.
3. MANHOLE TO BE PROVIDED WITH STEP IRONS EVENLY SPACED AT 300MM NOMINAL VERTICAL INTERVALS THE LOWEST IRON SHALL NOT BE MORE THAN 450MM ABOVE THE HAUNCHING AND THE HIGHEST NOT MORE THAN 600MM BELOW THE TOP SURFACE OF THE MANHOLE COVER.
4. CONCRETE PIPES SHALL BE RUBBER RING JOINTED AND SHALL BE CONSTRUCTED WITH ACCORDANCE WITH PWD SECTION 501 AND THE TYPICAL DRAWING IN APPENDIX 7.
5. ALL JOINTS AND/OR CONNECTIONS TO THE MANHOLES SHALL BE SEALED WITH EPOXY MORTAR. IN HIGH TRAFFICKED AREAS OR AS DIRECTED BY THE ENGINEER.
6. CAST IRON FRAMES ARE TO BE BOLTED TO THE CONCRETE MANHOLE TOP WITH 3No. M12 BOLTS EQUALLY SPACED.
7. MINIMUM RADIUS OF BENDING NOT LESS THAN PIPE DIAMETER.

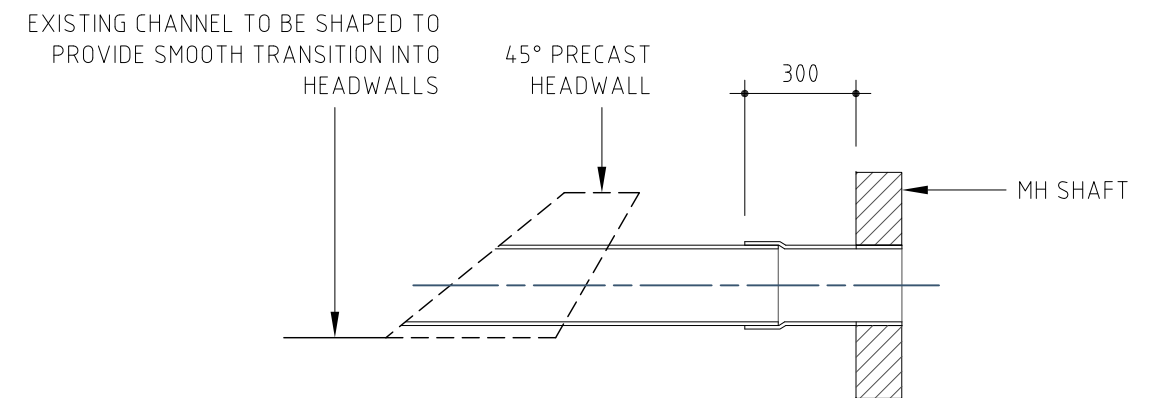

MANHOLE 2 - INLET SECTION

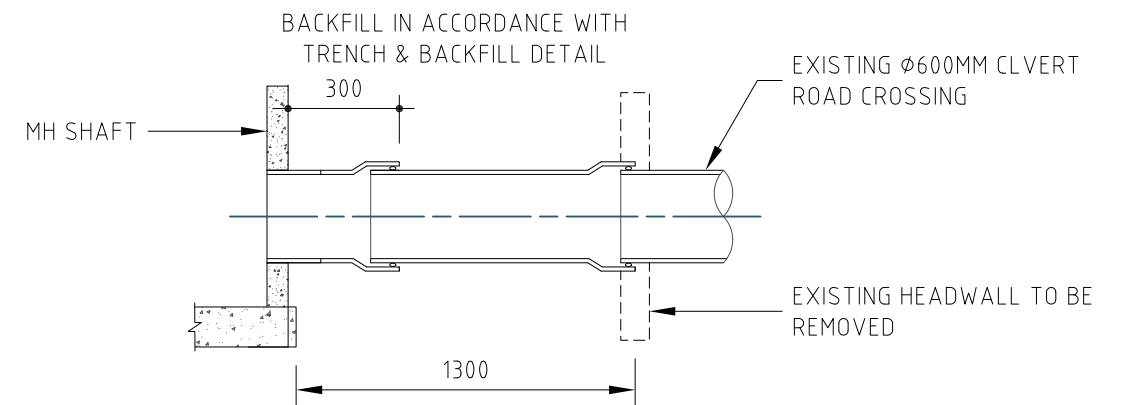

MANHOLE 2 - INLET SECTION



E				
D				
C				
B				
A				
ISSUE	APPD	DATE	AMENDMENT	BY

GENERAL NOTES

STANDARD DRAWINGS

STORMWATER MANHOLE DETAIL



SCALE	DATE	DESIGN BY	DRAWN BY	APPROVED	DRAWING No.	SHEET No.	ISSUE
	05 April 17		CWS		R 503 - 4	02	

PLOT DATE 12/03/2019

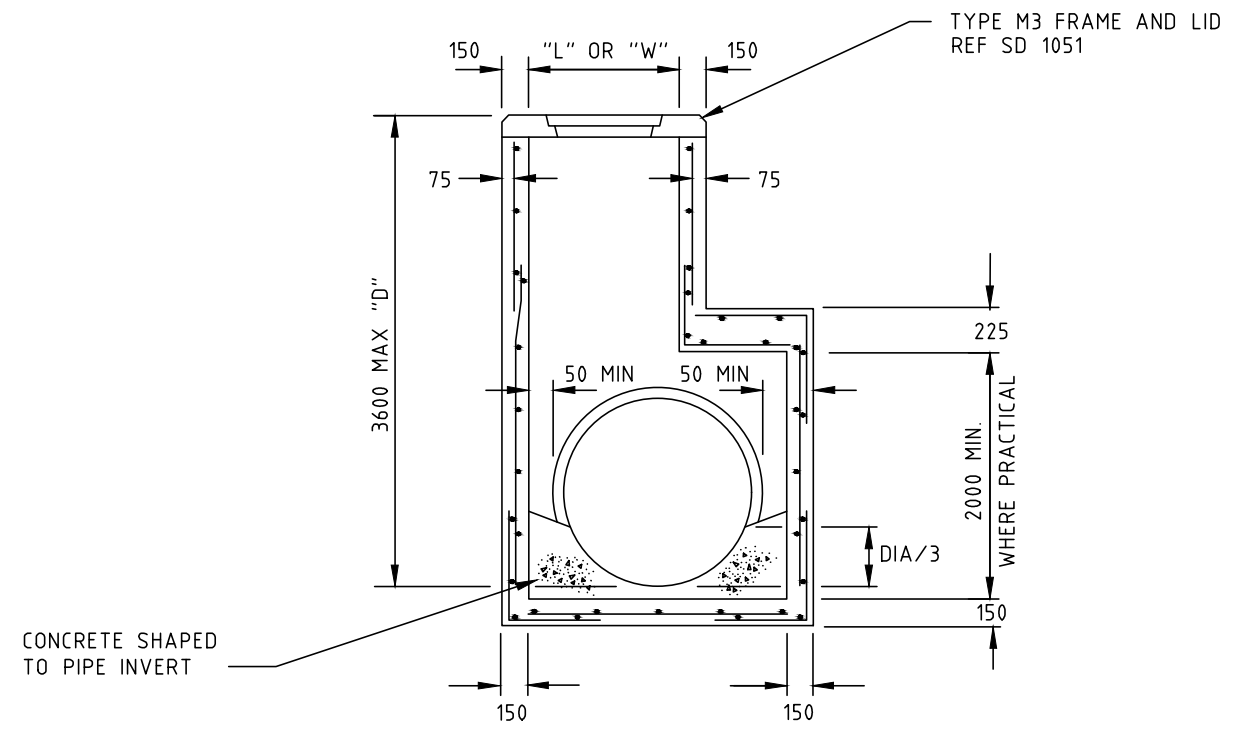

HAUNCHED PITS - UP TO 3600 DEPTH  
(FOR DEEPER PITS AND DETAILS REFER SD 1021)

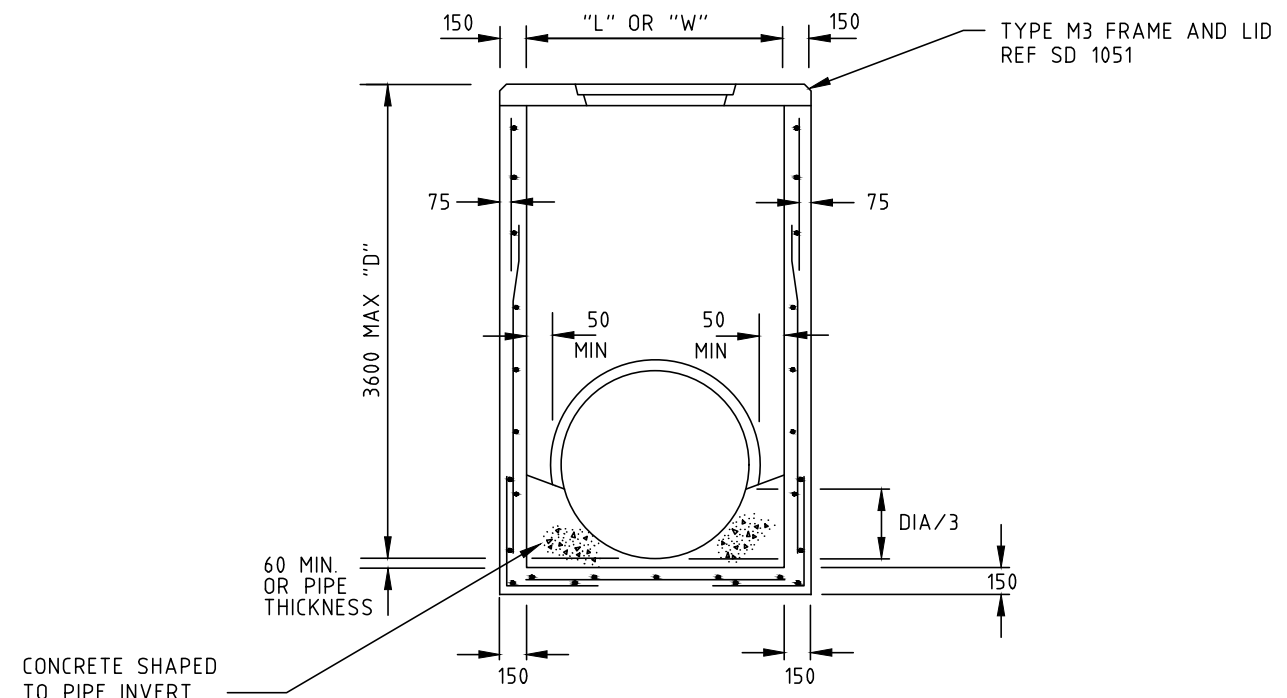

UNHAUNCHED PITS - UP TO 3600 DEPTH  
(FOR DEEPER PITS AND DETAILS REFER SD 1011)

REINFORCEMENT DETAILS

PIT LENGTH "L"	REINFORCEMENT
UP TO 1200	HD10 AT 150 CRS BOTHWAYS
1201 TO 1800	HD12 AT 125 CRS BOTHWAYS
1801 TO 2400	HD16 AT 125 CRS BOTHWAYS

NOTES:

- USE 750 x 750 PIT FOR JUNCTION PITS LOCATED IN OR WITHIN 300 mm OF TRAFFIC LANES. THESE PITS REQUIRE HEAVY DUTY COVERS. REFER SD 1131. FOR SUBSURFACE PITS DEEPER THAN 2.5 m USE JUNCTION PITS.
- FOR PITS NOT IN TRAFFIC LANES, THE STANDARD SHAFT SIZE IS 1000 x 750.
- HAUNCHING MAY BE REQUIRED FOR PIPES OVER 450 DIAMETER. REFER TO PIT SCHEDULE FOR SIZES OF SPECIFIC PITS. PITS WITH HAUNCHING IN TWO DIRECTIONS REQUIRE SPECIAL STRUCTURAL DESIGN.
- PIT REINFORCEMENT DETAILS ARE SHOWN IN TABLE. FABRIC IN SHAFT SHALL HAVE THE MAIN BARS POSITIONED HORIZONTALLY. LAPS TO BE 300 MIN. CLEAR COVER TO BE 50 MIN. CORNER RETURN REINFORCEMENT MAY BE FABRIC OR EQUIVALENT BARS. BARS GRADE 400Y & FABRICS TO COMPLY WITH AS/NZS 4671 CONCRETE SHALL BE NORMAL-CLASS N32 STANDARD STRENGTH GRADE OR HIGHER COMPLYING WITH THE REQUIREMENTS OF AS 1379. EXPOSURE CLASSIFICATIONS UP TO AND INCLUDING B1.
- PITS DEEPER THAN 1000 SHALL BE FITTED WITH STEP IRONS. REFER SD 1041.
- PRECAST UNITS MAY BE CONSTRUCTED TO THE MANUFACTURER'S DETAILS. THE DESIGN SHALL COMPLY WITH THE AS 5100 BRIDGE DESIGN AND THE FOLLOWING ADDITIONAL REQUIREMENTS :
  - COMBINED FACTORED LATERAL PRESSURE AT ANY POINT AT THE ULTIMATE LIMIT STATE SHALL BE NOT LESS THAN 25 kPa.
  - ADEQUATE DRAINAGE SHALL BE PROVIDED TO PIT WALLS TO AVOID HYDROSTATIC PRESSURE.
  - VERTICAL LOAD 210 kN APPLIED ANYWHERE ON PIT.
  - MINIMUM REINFORCEMENT AREA SHALL BE 150 mm<sup>2</sup>/m.
  - CONCRETE AGGREGATES SHALL COMPLY WITH TABLE 701.021 OF VICROADS STANDARD SPECIFICATION SECTION 701.
- CONCRETE FRAMES TO BE SET ON 5 mm OF MORTAR.

GENERAL NOTES  
1. BASED ON VICROADS Drawing SD 1121

STANDARD DRAWINGS  
JUNCTION PIT - CONCRETE COVER



ISSUE	APP'D	DATE	AMENDMENT	BY
E				
D				
C				
B				
A				

SCALE	DATE 05 April 17	DESIGN BY	DRAWN BY CWS	APPROVED	DRAWING No. R 503 - 5	SHEET No. 02	ISSUE
-------	---------------------	-----------	-----------------	----------	--------------------------	-----------------	-------

PLOT DATE 12/03/2019

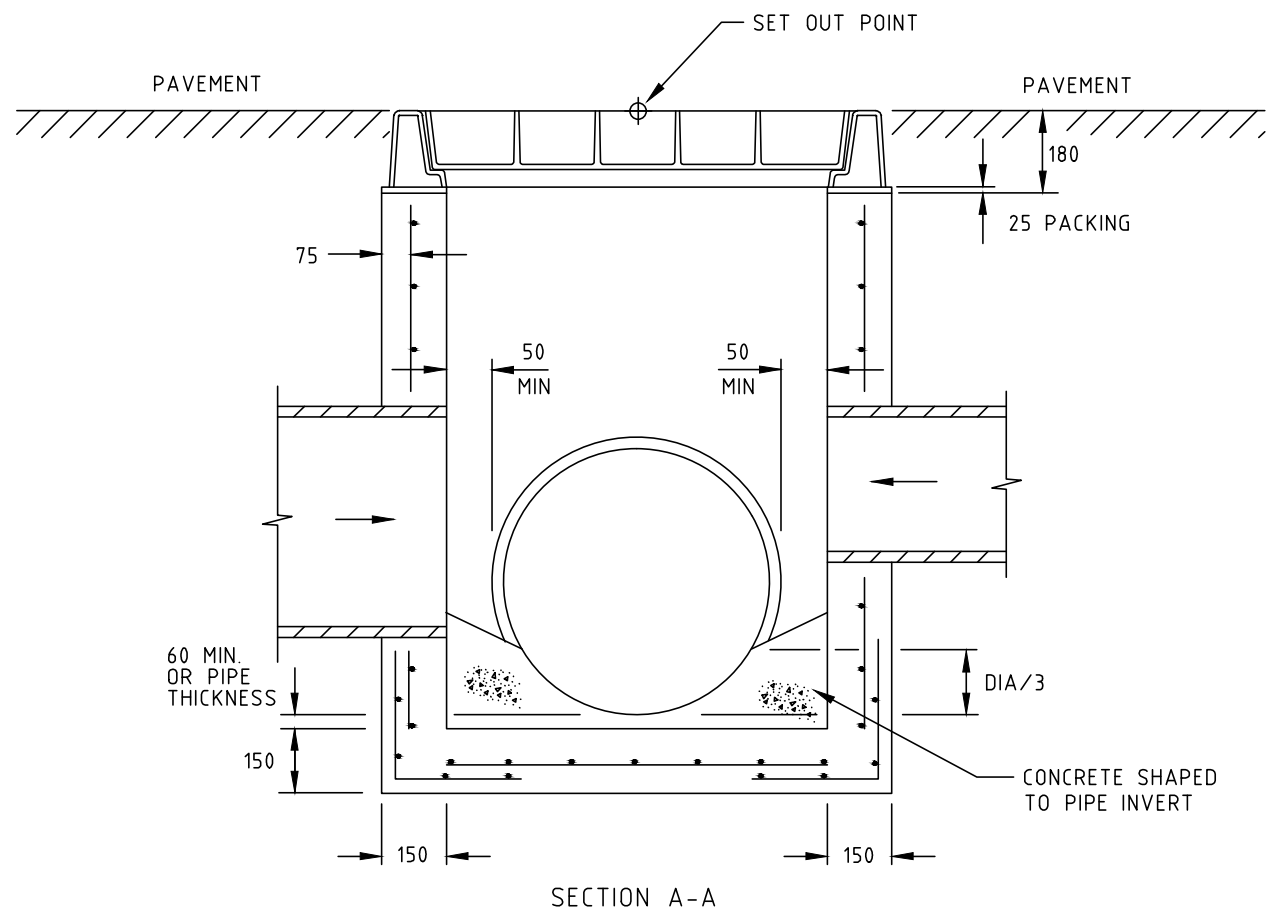

SECTION A-A

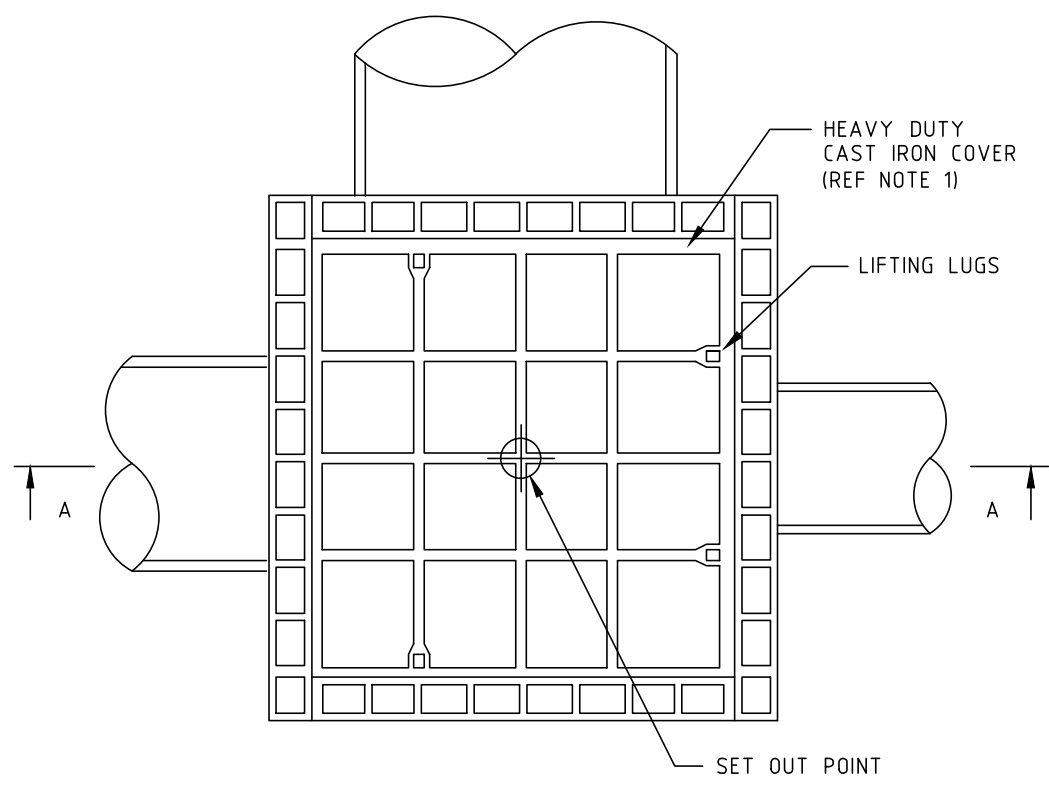

PLAN

NOTES:

1. CAST IRON COVERS AND FRAMES ARE TO BE USED FOR PITS LOCATED IN OR WITHIN 300 mm OF TRAFFIC LANES. USE EITHER GATIC HEAVY DUTY B144 (750 x 750) OR GATIC HEAVY DUTY H212 CIRCULAR (600 DIA) COVER OR A COVER WITH EQUIVALENT STRENGTH.
2. EACH COVER SHALL HAVE WEIGHT AND CAPACITY CLEARLY IMPRINTED ON THE TOP.
3. FRAMES MUST HAVE ADEQUATE ANCHORAGE TO ENSURE THAT THEY DO NOT COME LOOSE UNDER TRAFFIC.
4. USE 750 x 750 SHAFT SIZE FOR JUNCTION PITS LOCATED IN TRAFFIC LANES.
5. USE STANDARD SHAFT SIZE 1000 x 750 FOR PITS LOCATED OUTSIDE TRAFFIC LANES.
6. HAUNCHING MAY BE REQUIRED FOR PIPES OVER 450 DIAMETER. REFER TO PIT SCHEDULE FOR SIZES OF SPECIFIC PITS. PITS WITH HAUNCHING IN TWO DIRECTIONS REQUIRE SPECIAL STRUCTURAL DESIGN.
7. PIT REINFORCEMENT DETAILS ARE SHOWN IN TABLE. FABRIC IN SHAFT SHALL HAVE THE MAIN BARS POSITIONED HORIZONTALLY. LAPS TO BE 300 MIN. CLEAR COVER TO BE 50 MIN. CORNER RETURN REINFORCEMENT MAY BE FABRIC OR EQUIVALENT BARS. BARS GRADE 400Y & FABRICS TO COMPLY WITH AS/NZS 4671. CONCRETE SHALL BE NORMAL-CLASS N32 STANDARD STRENGTH GRADE OR HIGHER COMPLYING WITH THE REQUIREMENTS OF AS 1379. EXPOSURE CLASSIFICATIONS UP TO AND INCLUDING B1.
8. PITS DEEPER THAN 1000 SHALL BE FITTED WITH STEP IRONS. REFER SD 1041.
9. PRECAST UNITS MAY BE CONSTRUCTED TO THE MANUFACTURER'S DETAILS. THE DESIGN SHALL COMPLY WITH THE AS 5100 BRIDGE DESIGN AND THE FOLLOWING ADDITIONAL REQUIREMENTS :
  - COMBINED FACTORED LATERAL PRESSURE AT ANY POINT AT THE ULTIMATE LIMIT STATE SHALL BE NOT LESS THAN 25 kPa.
  - ADEQUATE DRAINAGE SHALL BE PROVIDED TO PIT WALLS TO AVOID HYDROSTATIC PRESSURE.
  - VERTICAL LOAD 210 kN APPLIED ANYWHERE ON PIT.
  - MINIMUM REINFORCEMENT AREA SHALL BE 150 mm<sup>2</sup>/m.
  - CONCRETE SHALL BE NORMAL-CLASS N32 STANDARD STRENGTH GRADE OR HIGHER COMPLYING WITH THE REQUIREMENTS OF AS 1379. EXPOSURE CLASSIFICATIONS UP TO AND INCLUDING B1.
10. CONCRETE INFILL FOR COVER AND FRAME SHALL BE N32 AT 28 DAYS WITH 10 MAX SIZE AGGREGATE. TAMP AND PENCIL VIBRATE.
11. CAST IRON COVER AND FRAME TO BE INSTALLED AS ONE UNIT.

REINFORCEMENT DETAILS

PIT LENGTH "L"	REINFORCEMENT
UP TO 1200	HD10 AT 150 CRS BOTHWAYS
1201 TO 1800	HD12 AT 125 CRS BOTHWAYS
1801 TO 2400	HD16 AT 125 CRS BOTHWAYS

ISSUE	APP'D	DATE	AMENDMENT	BY
E				
D				
C				
B				
A				

GENERAL NOTES  
1. BASED ON VICROADS Drawing SD 1131

STANDARD DRAWINGS				
JUNCTION PIT - CAST IRON COVER				
SCALE	DATE	DESIGN BY	DRAWN BY	APPROVED
	05 April 17		CWS	

Fiji Roads Authority

DRAWING No.	R 503 - 6	SHEET No.	02	ISSUE	
-------------	-----------	-----------	----	-------	--

# INDEX SHEET

## SERIES 504 V DRAIN DETAILS

DRAWING NUMBER	DRAWING TITLE
R 504 - 1	OPEN DRAIN LINED WITH CONCRETE INVERT
R 504 - 2	OPEN DRAIN LINED WITH CONCRETE INVERT
R 504 - 3	CONCRETE OPEN CHANNEL TYPES 1,2,3,4
R 504 - 4	TYPES 2 & 3 CONCRETE OPEN CHANNEL
R 504 - 5	PRECAST INVERT DRAIN CROSSING
R 504 - 6	CROSSING FOR UNFORMED FOOTPATH & DRAIN
R 504 - 7	STANDARD CROSSING FOR WIDE DRAINS
R 504 - 8	TYPICAL DRIVEWAY IN CUT ACCESS DETAILS
R 504 - 9	CATCH DRAIN TYPE A
R 504 - 10	CATCH DRAIN TYPE B
R 504 - 11	CATCH DRAIN TYPE C

---

PLOT DATE 18/10/2018

150  
100  
50  
40  
30  
20  
10

**NOTES:**  
1. EXPANSION JOINTS SHALL BE PROVIDED USING PRE-MOULDED FILLER EXTENDING OVER THE FULL CROSS SECTION OF THE DRAIN.

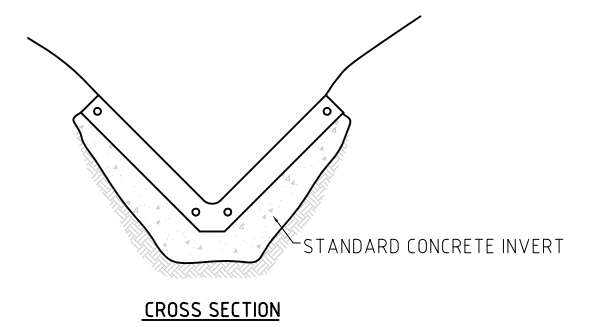
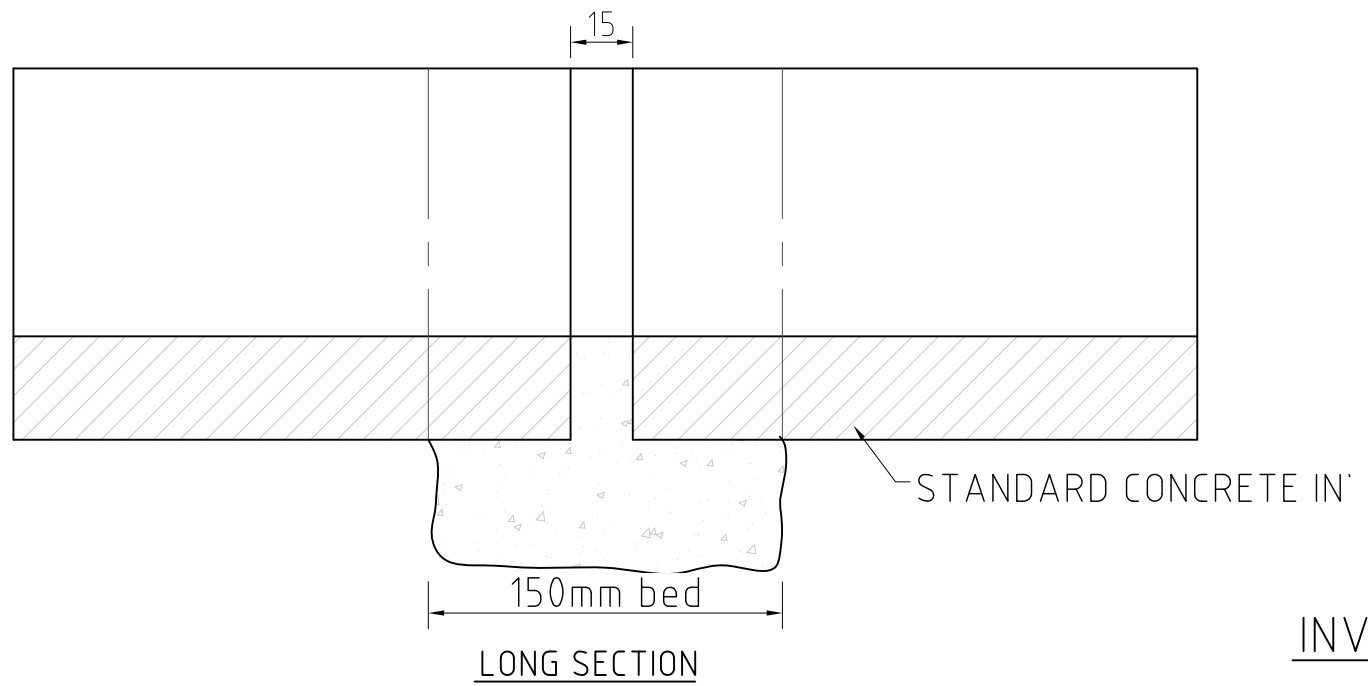
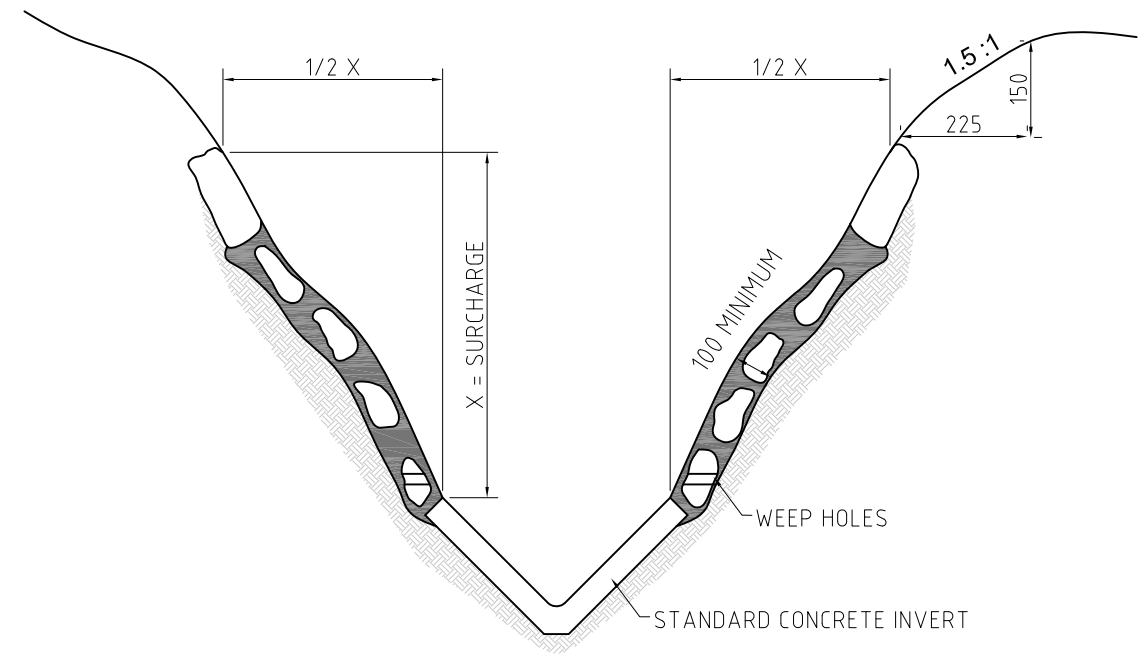

INVERT JOINTING DETAIL

A3 ORIGINAL SIZE	E				
	D				
	C				
	B				
	A				
ISSUE	APPD	DATE	AMENDMENT	BY	

GENERAL NOTES

<b>STANDARD DRAWINGS</b>		
<b>OPEN DRAIN LINED WITH CONCRETE INVERT</b>		
SCALE	DATE	DESIGN BY
	05 April 17	

**Fiji Roads Authority**

DRAWN BY	APPROVED	DRAWING No.	SHEET No.	ISSUE
CWS		R 504 - 1	01	

PLOT DATE 18/10/2018

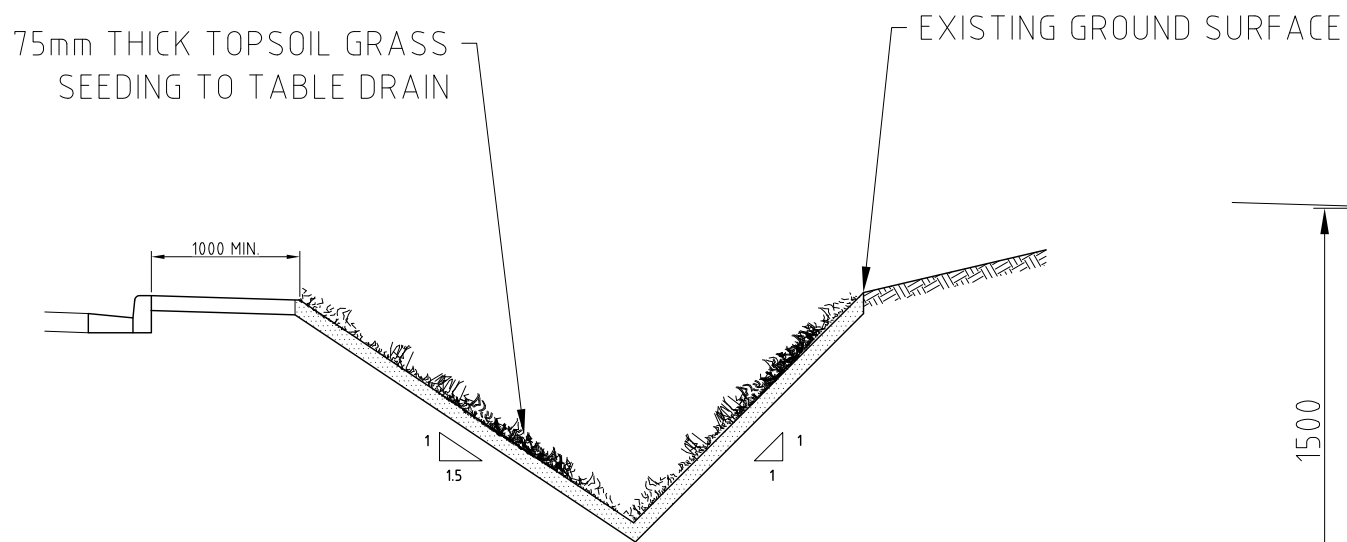

**TYPICAL DRAIN TYPE I - V DRAIN**  
SCALE 1 : 25

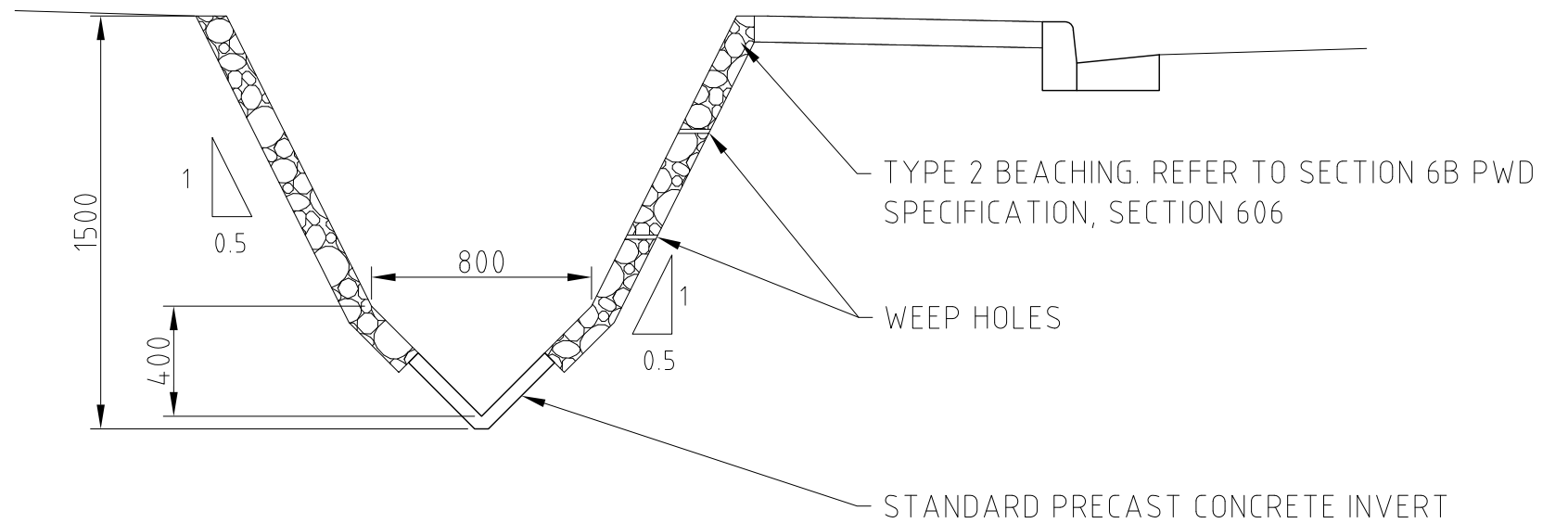

**TYPICAL DRAIN TYPE II - V DRAIN**  
SCALE 1 : 25

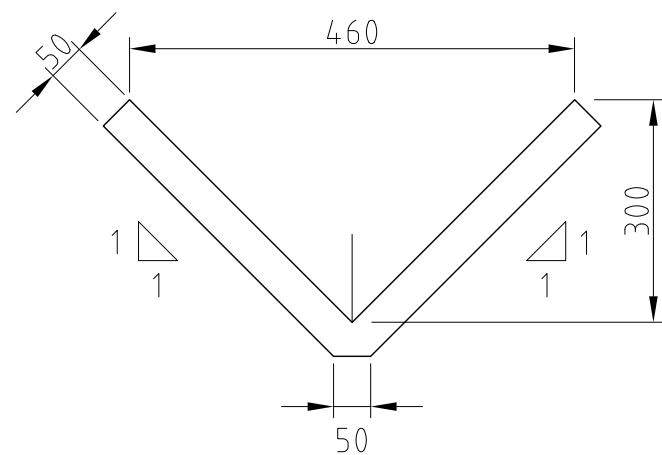

**PRECAST CONCRETE INVERT DETAIL**  
SCALE 1 : 10

**NOTES:**

1. FOR SUB-SOIL DRAIN DETAILS REFER TO DRG. NO. R 502 / 1 & R 502 / 2
2. ALL DIMENSIONS SHOWN IN MILLIMETRES UNLESS OTHERWISE SHOWN
3. GROUND CONDITIONS WILL REQUIRE / DETERMINE THE SUITABILITY OF USING UN-LINED / UN-REINFORCEABLE DRAIN. THE GROUND CONDITIONS SHALL BE ACCURATELY ASSESSED, HOWEVER THE FOLLOWING SHALL APPLY IN GENERAL:
  - a. AN OPEN DRAIN WITH A BACK SLOPE 1 V : 1 H SHALL BE LIMITED TO 1m DRAIN DEPTH. FROM TOP OF BANK TO DRAIN INVERT / BONE LEVEL.
  - b. DRAINS EXCEEDING 1m DEPTH BUT NOT EXCEEDING 1.5m SHALL HAVE ADDITIONAL SIDE SUPPORT EITHER USING A STONE FACE LINING CEMENTED IN PLACE AS PER TYPICAL DRAIN DETAIL C, OR ANOTHER SUITABLE ENGINEERING SOLUTION AGREED ON SITE BY THE ENGINEER.
  - c. GENERALLY DRAINS SHALL NOT BE CONSTRUCTED EXCEEDING 1.5m DEPTH WHILST ADDITIONAL MEASURES DEPLOYED TO MITIGATE AGAINST THE RISK OF COLLAPSING SIDES. SUCH MEASURES MAY REQUIRE CONSTRUCTION OF CONCRETE CHANNEL SECTIONS IN DRAIN BOTTOM / INVERT TO REDUCE THE EFFECTIVE SOIL BANK HEIGHT.
  - d. CONCRETE COVER TO REINFORCING BARS TO BE 40mm MINIMUM IN ALL CASES.

A3 ORIGINAL SIZE

E				
D				
C				
B				
A				
ISSUE	APPD	DATE	AMENDMENT	BY

GENERAL NOTES

<b>STANDARD DRAWINGS</b>			
<b>OPEN DRAIN LINED WITH CONCRETE INVERT</b>			
SCALE	DATE	DESIGN BY	DRAWN BY
	05 April 17		CWS

Fiji Roads Authority

APPROVED	DRAWING No.	SHEET No.	ISSUE
	R 504 - 2	01	

PLOT DATE 18/10/2018

150

100

50

40

30

20

10

A3 ORIGINAL SIZE

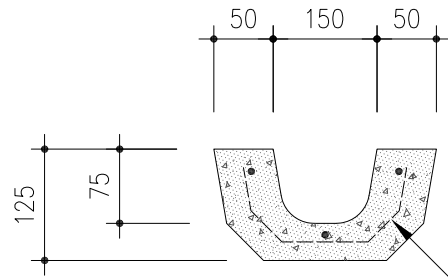

REINFORCEMENT WITH 3No. 6MM DIA.  
MS BARS AND 6MM DIA. MS TIES AT  
270MMcrs.

CONCRETE DRAIN  
TYPE 1

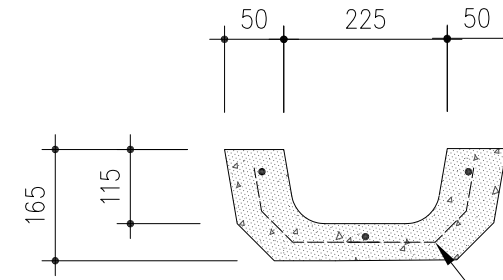

REINFORCEMENT WITH 3No. 6MM DIA.  
MS BARS AND 6MM DIA. MS TIES AT  
270MMcrs.

CONCRETE DRAIN  
TYPE 2

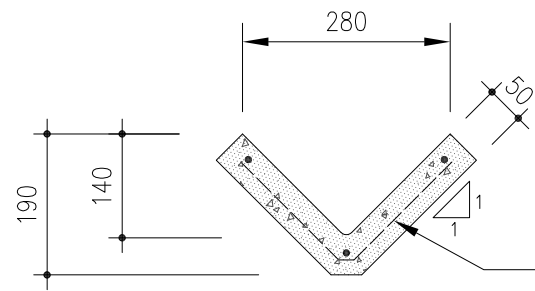

REINFORCEMENT WITH 3No. 6MM DIA.  
MS BARS AND 6MM DIA. MS TIES AT  
270MMcrs.

CONCRETE DRAIN  
TYPE 3

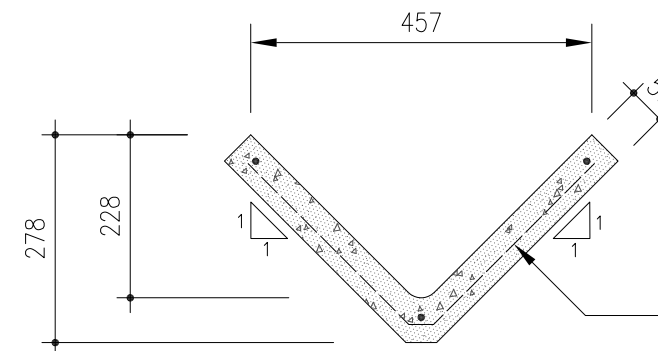

REINFORCEMENT WITH 3No. 6MM DIA.  
MS BARS AND 6MM DIA. MS TIES AT  
270MMcrs.

OPEN CHANNEL  
TYPE 4

ISSUE	APPD	DATE	AMENDMENT	BY
E				
D				
C				
B				
A				

GENERAL NOTES

STANDARD DRAWINGS  
CONCRETE DRAIN  
TYPES 1, 2, 3 & 4



SCALE	DATE 02 MAY 17	DESIGN BY	DRAWN BY CWS	APPROVED A KETENILAGI	DRAWING No. R 504 - 3	SHEET No. 01	ISSUE
-------	-------------------	-----------	-----------------	--------------------------	--------------------------	-----------------	-------

PLOT DATE 18/10/2018

150

100

50

40

30

20

10

A3 ORIGINAL SIZE

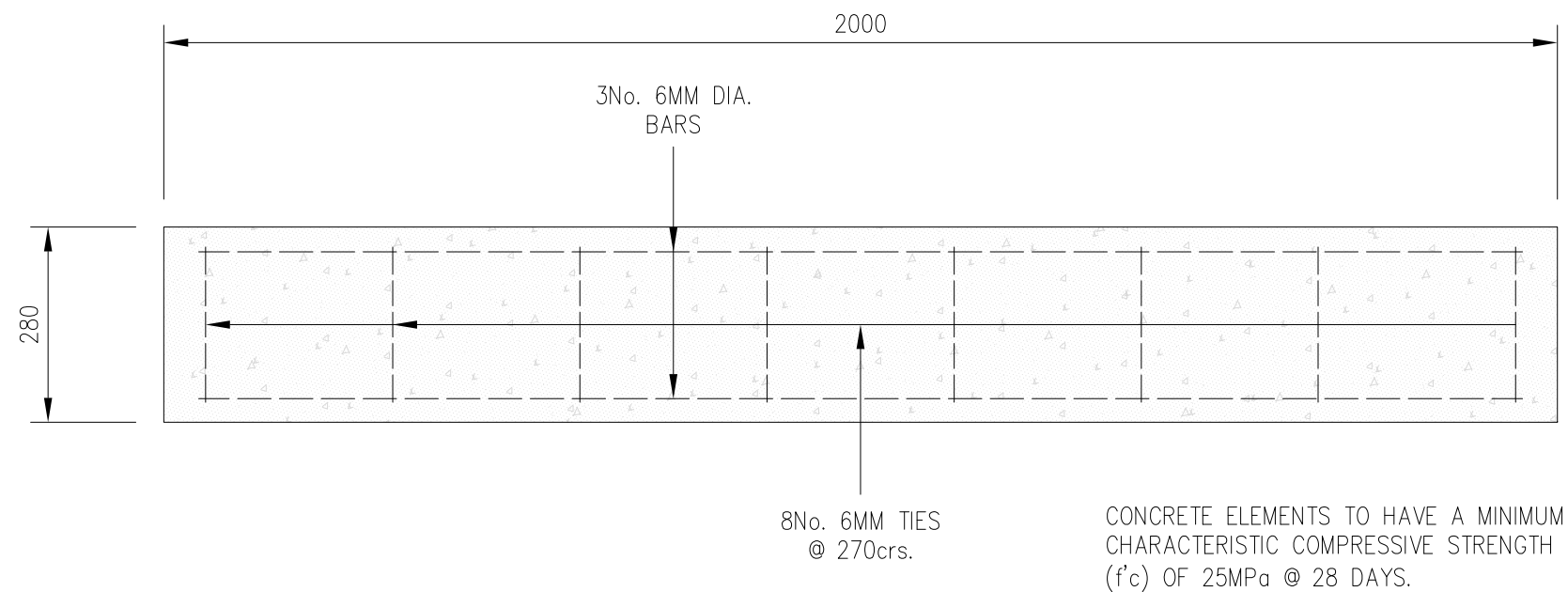

8No. 6MM TIES @ 270crs.

CONCRETE ELEMENTS TO HAVE A MINIMUM CHARACTERISTIC COMPRESSIVE STRENGTH ( $f'_c$ ) OF 25MPa @ 28 DAYS.

ELEVATION

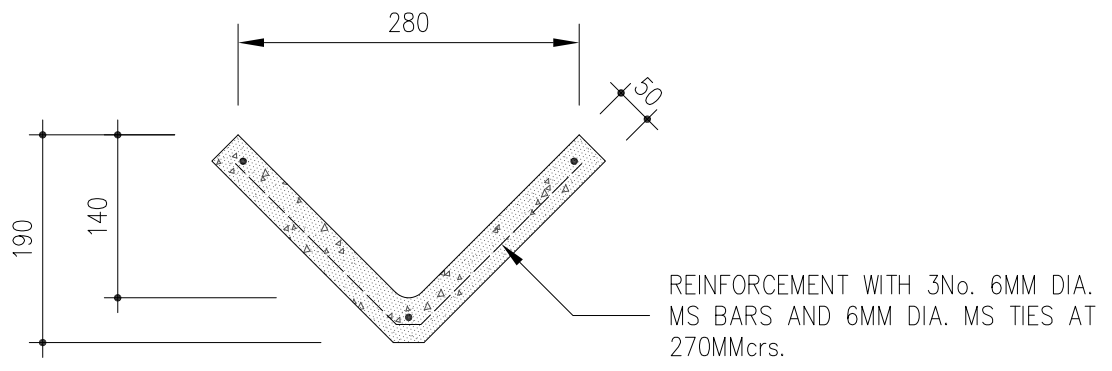

REINFORCEMENT WITH 3No. 6MM DIA. MS BARS AND 6MM DIA. MS TIES AT 270MMcrs.

OPEN CHANNEL TYPE 2

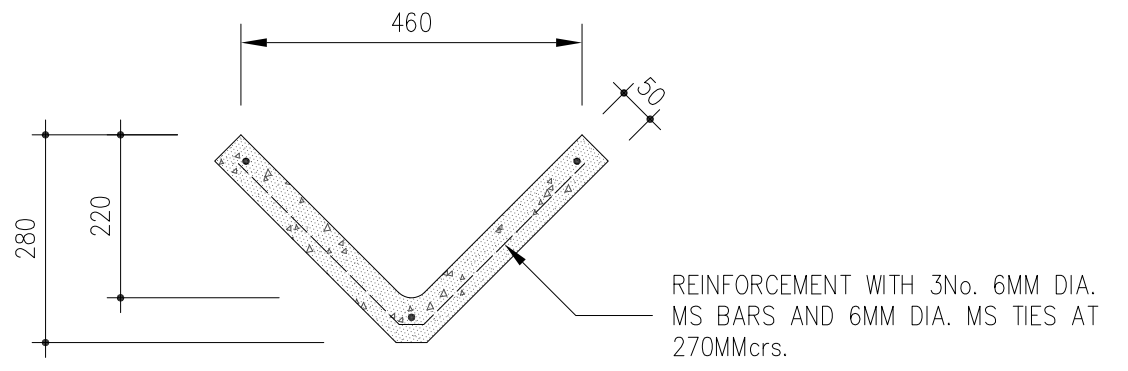

REINFORCEMENT WITH 3No. 6MM DIA. MS BARS AND 6MM DIA. MS TIES AT 270MMcrs.

OPEN CHANNEL TYPE 3

E				
D				
C				
B				
A				
ISSUE	APPD	DATE	AMENDMENT	BY

GENERAL NOTES

STANDARD DRAWINGS		
TYPE 2 AND 3 CONCRETE OPEN CHANNEL DETAIL		
SCALE	DATE	DESIGN BY
	02 MAY 17	

**Fiji Roads Authority**

DRAWN BY	APPROVED	DRAWING No.	SHEET No.	ISSUE
CWS	A KETENILAGI	R 504 - 4	01	

PLOT DATE 20/03/2019

150  
100  
50  
40  
30  
20  
10

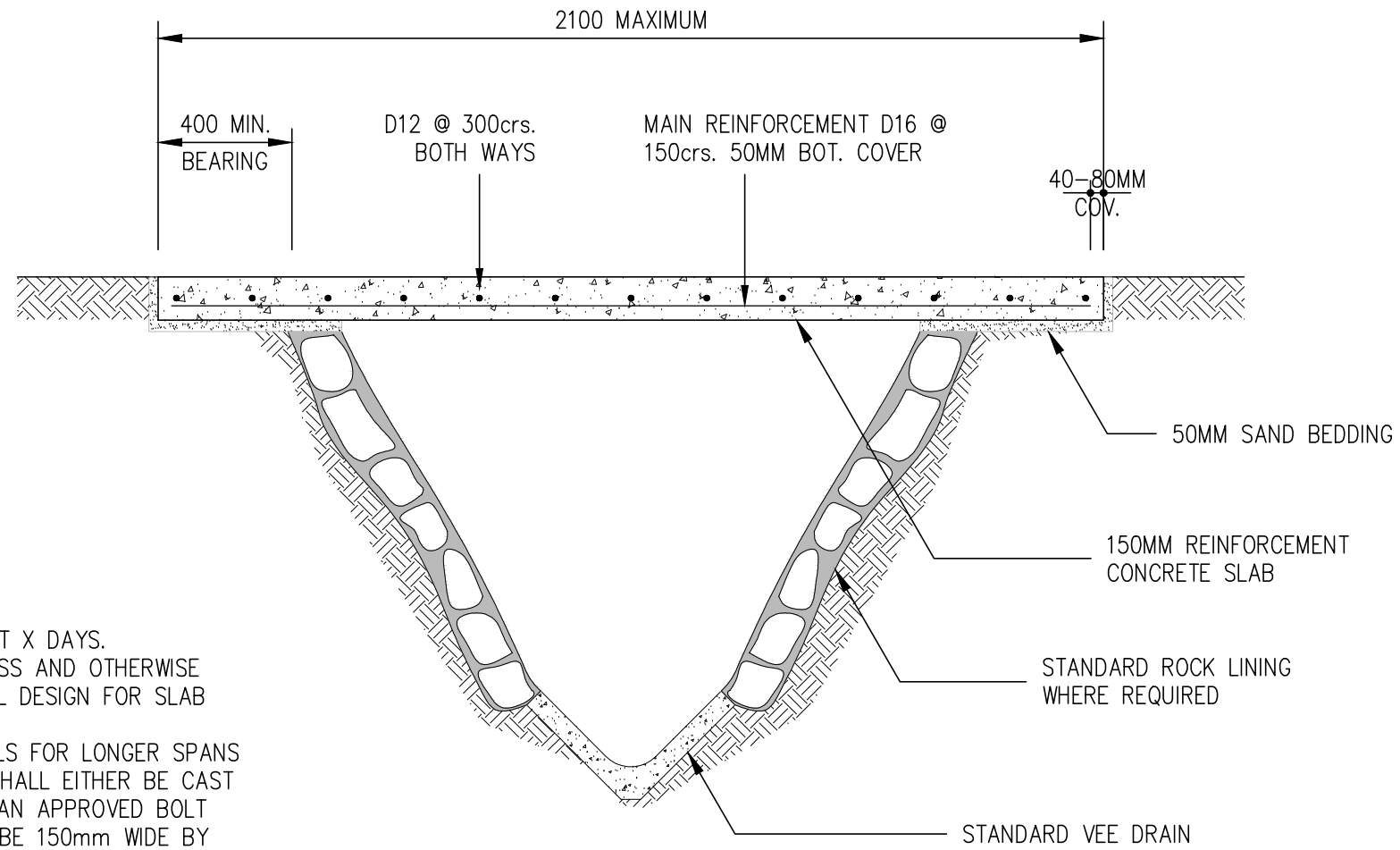

**TYPICAL CROSS - SECTION**

Scale 1:15

**NOTE**

1. CONCRETE STRENGTH TO BE 25MP<sub>a</sub> AT X DAYS. ALL DIMENSIONS IN MILLIMETERS UNLESS AND OTHERWISE STATED. FOR GREATER SPANS SPECIAL DESIGN FOR SLAB BEARING WILL BE REQUIRED.
2. REFER R504 - 7 FOR FOOTING DETAILS FOR LONGER SPANS
3. IF FRA DIRECTS USE OF A KERB, IT SHALL EITHER BE CAST INTO THE SLAB OR ATTACHED USING AN APPROVED BOLT DOWN METHOD. KERB PROFILE SHALL BE 150mm WIDE BY 100mm HIGH.
4. FRA TO CONFIRM NUMBER OF DAYS TO OBTAIN 25MP<sub>a</sub> IN ACCORDANCE WITH ACCESS NEEDS.

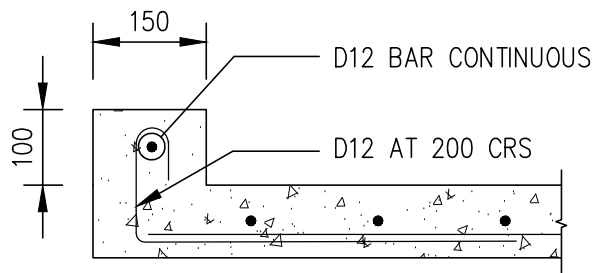

**OPTIONAL KERB DETAIL**

Scale 1:10

A3 ORIGINAL SIZE	E				
	D				
	C				
	B				
	A				
ISSUE	APP'D	DATE	AMENDMENT	BY	GENERAL NOTES

GENERAL NOTES

<b>STANDARD DRAWINGS</b>				
<b>PRECAST INVERT DRAIN CROSSING</b>				
SCALE	DATE	DESIGN BY	DRAWN BY	APPROVED
	02 MAY 17		CWS	A KETENILAGI

**DRAWING No.** R 504 - 5

**SHEET No.** 01

**ISSUE**

PLOT DATE 18/10/2018

150

100

50

40

30

20

10

A3 ORIGINAL SIZE

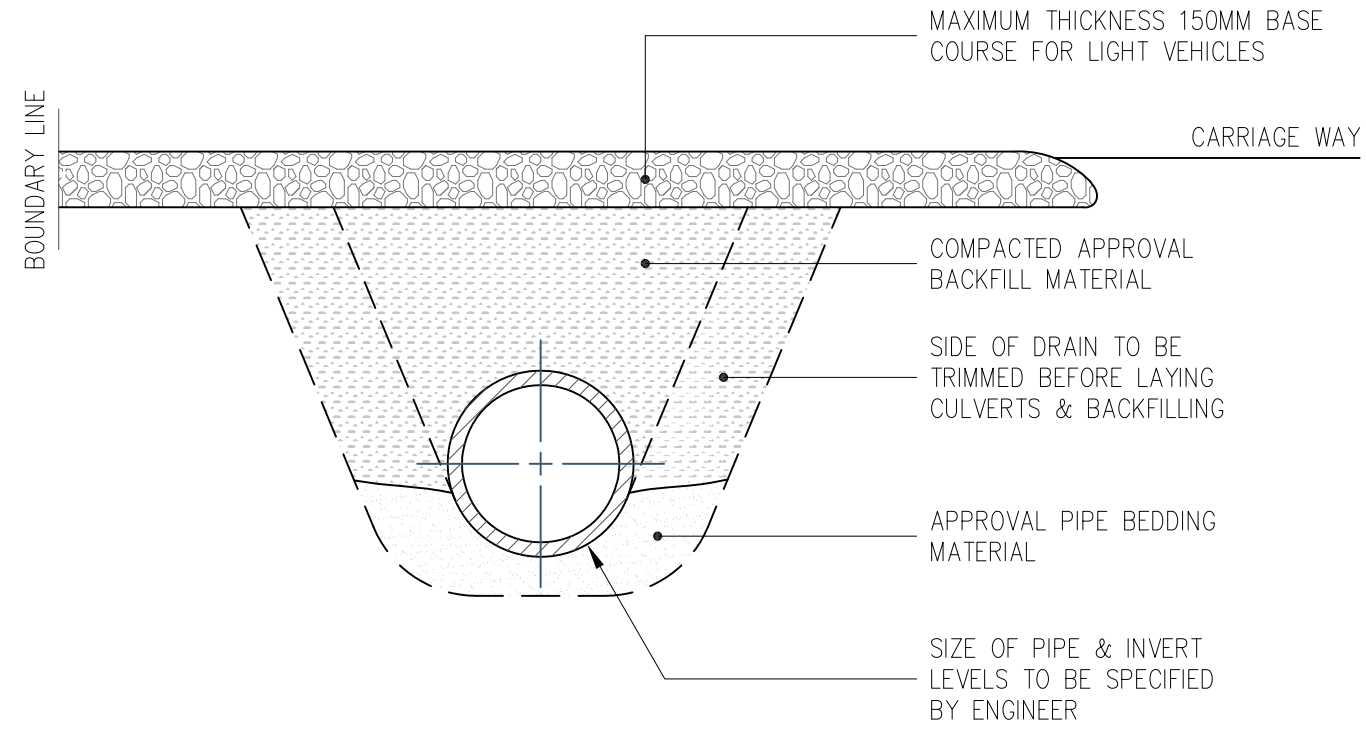

SECTION A-A Scale 1:20

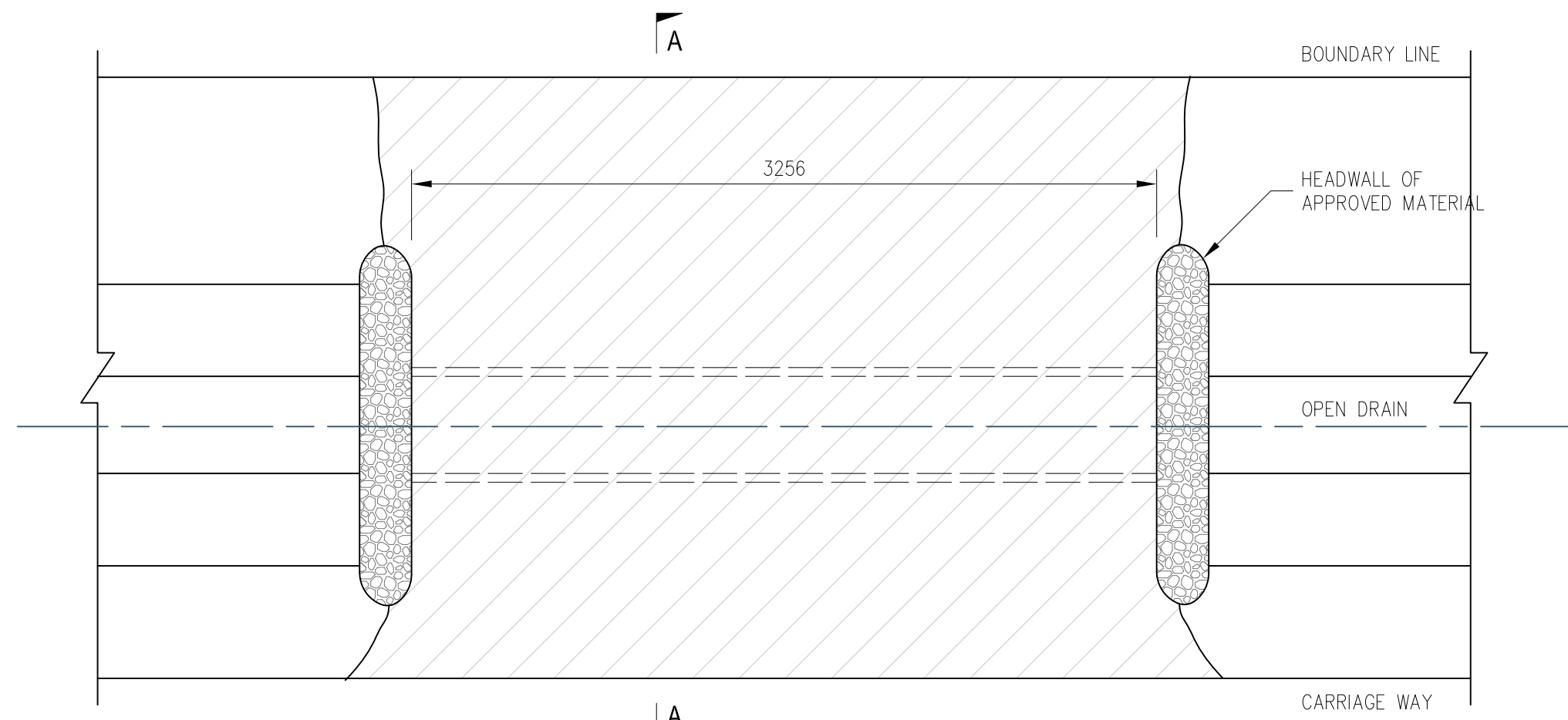

PLAN Scale 1:25

ISSUE	APPD	DATE	AMENDMENT	BY
E				
D				
C				
B				
A				

GENERAL NOTES

<b>STANDARD DRAWINGS</b> <b>CROSSING FOR UNFORMED</b> <b>FOOTPATH &amp; DRAIN</b>			
SCALE	DATE	DESIGN BY	DRAWN BY
	02 MAY 17		CWS

**Fiji Roads Authority**

APPROVED	DRAWING No.	SHEET No.	ISSUE
A KETENILAGI	R 504 - 6	01	

PLOT DATE 12/03/2019

150  
100  
50  
40  
30  
20  
10

A3 ORIGINAL SIZE

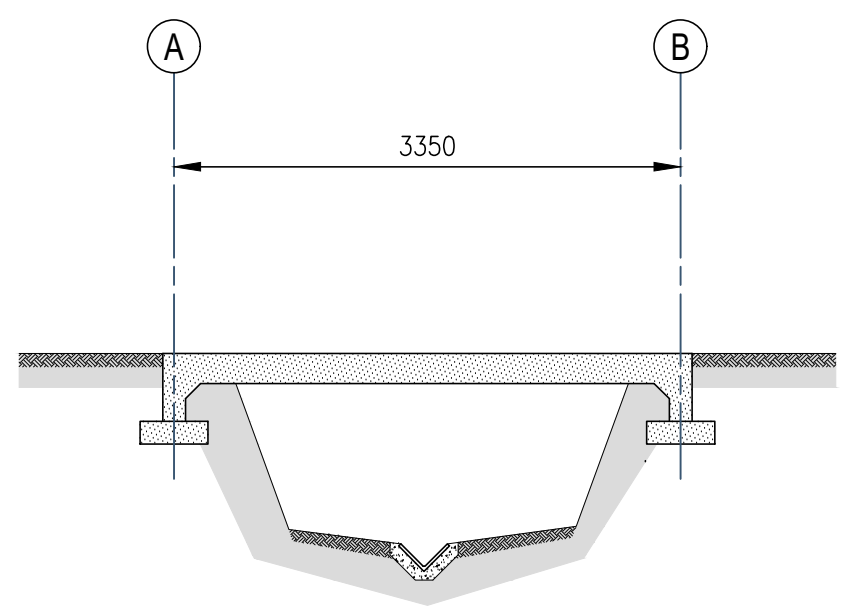

**TYPICAL CROSS - SECTION**  
Scale 1:50

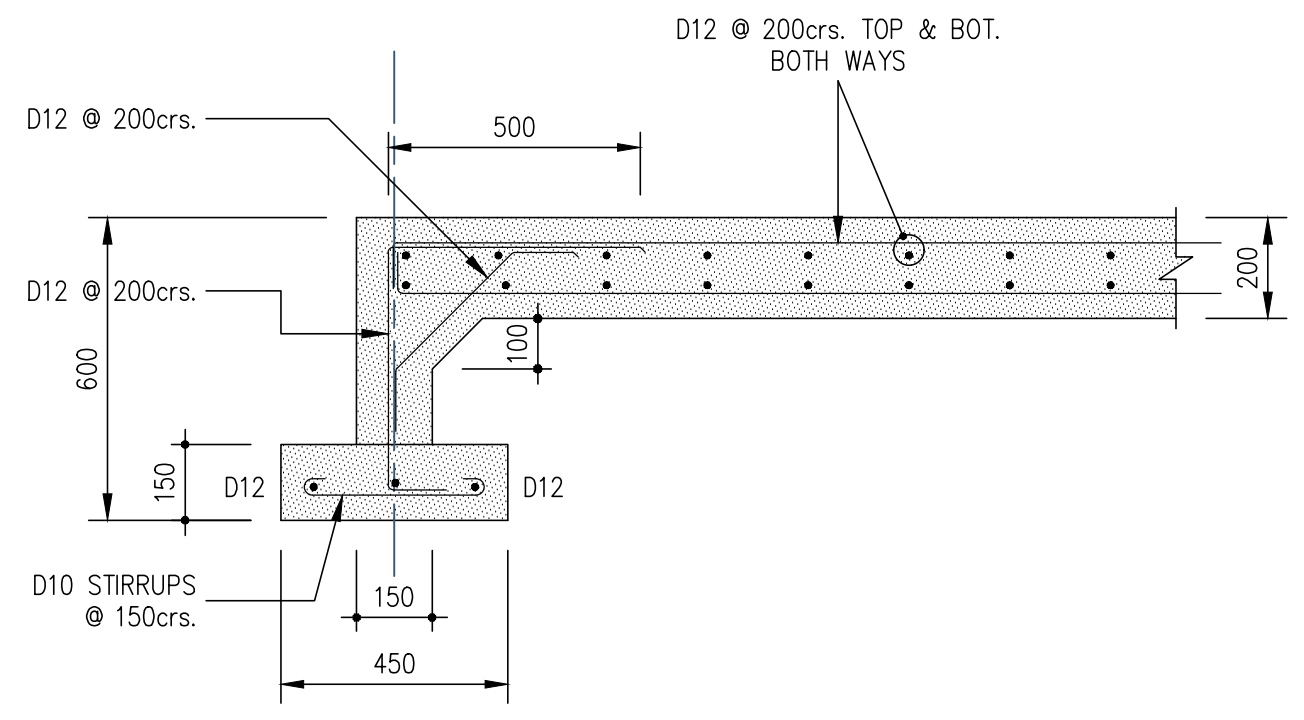

**SECTION A - A**  
Scale 1:15

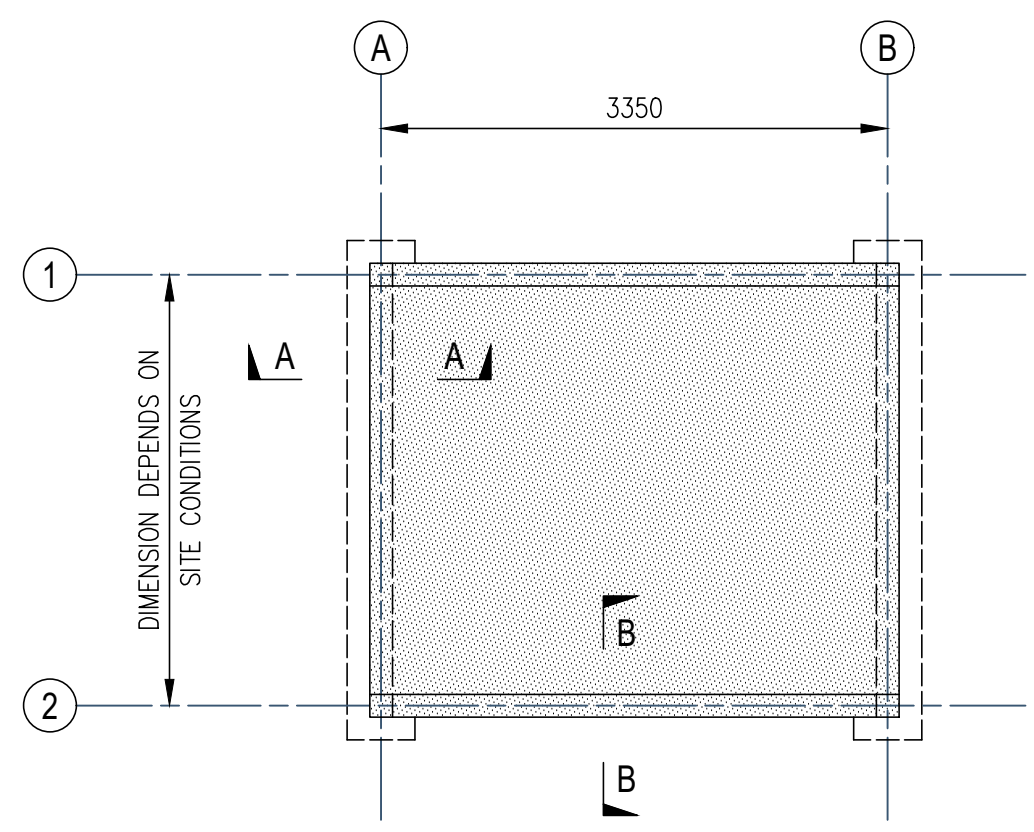

**PLAN**

**NOTE**

1. CONCRETE STRENGTH TO BE 25MPa AT X DAYS. ALL DIMENSIONS IN MILLIMETERS UNLESS AND OTHERWISE STATED. FOR GREATER SPANS SPECIAL DESIGN FOR SLAB BEARING WILL BE REQUIRED.
2. FRA TO CONFIRM NUMBER OF DAYS TO OBTAIN 25MPa IN ACCORDANCE WITH ACCESS REQUIREMENTS.

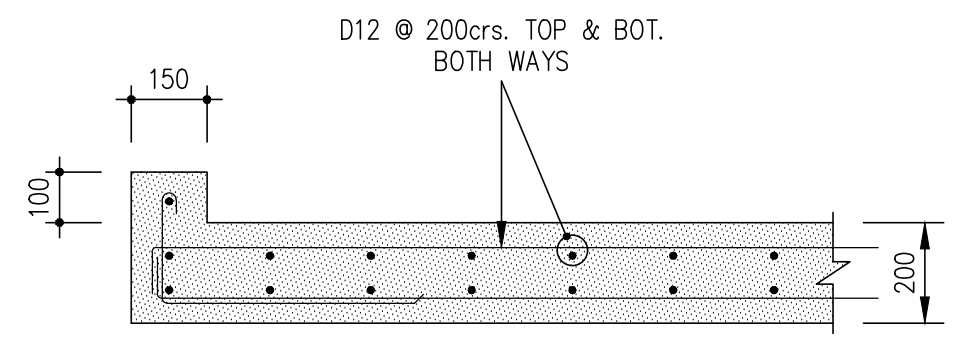

**SECTION B - B**  
Scale 1:15

ISSUE	APPD	DATE	AMENDMENT	BY
E				
D				
C				
B				
A				

GENERAL NOTES

<b>STANDARD DRAWINGS</b>				
<b>STANDARD CROSSING FOR WIDE DRAINS</b>				
SCALE	DATE	DESIGN BY	DRAWN BY	APPROVED
	02 MAY 17		CWS	A KETENILAGI

Fiji Roads Authority

DRAWING No.	R 504 - 7	SHEET No.	01	ISSUE	
-------------	-----------	-----------	----	-------	--

PLOT DATE 18/10/2018

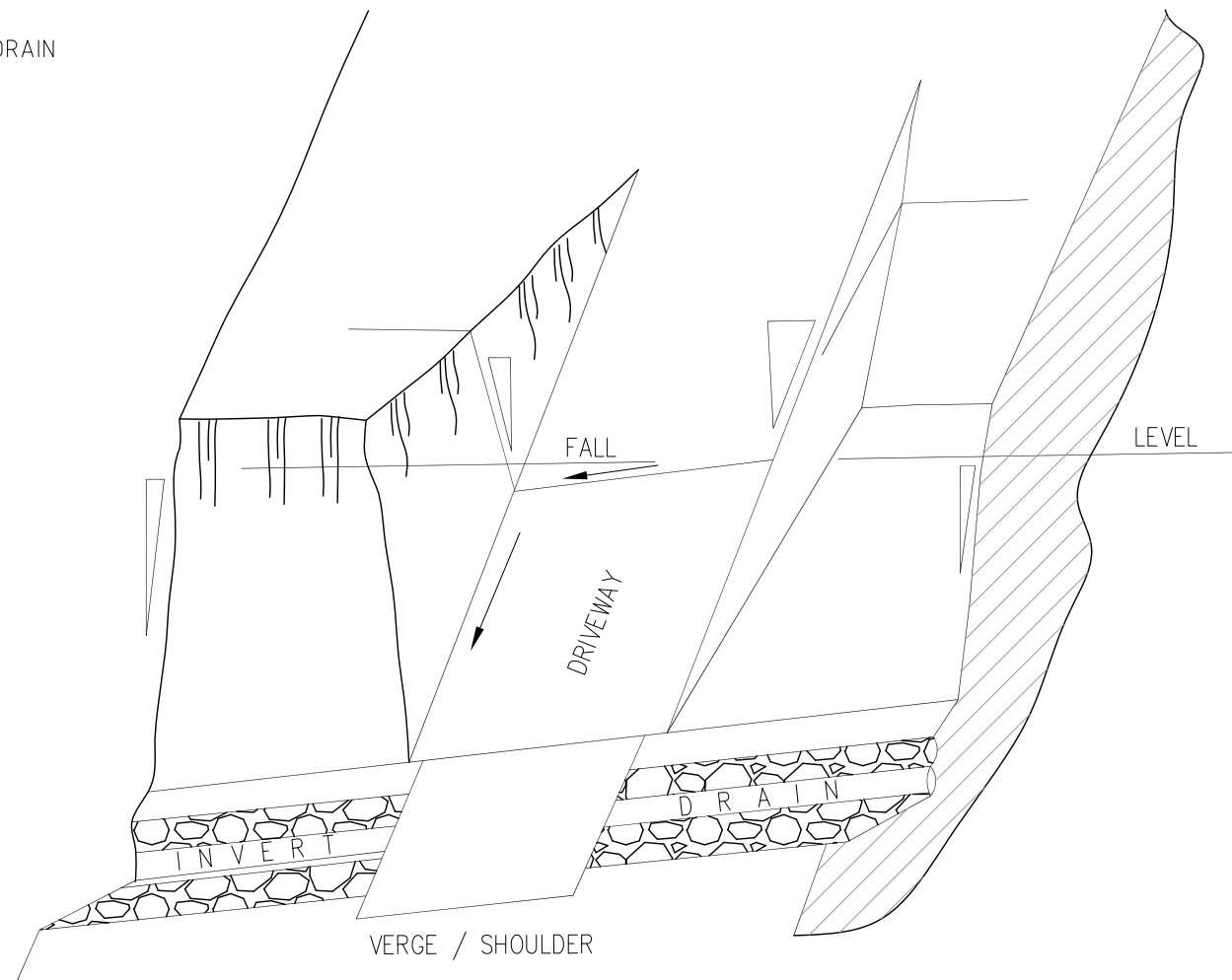
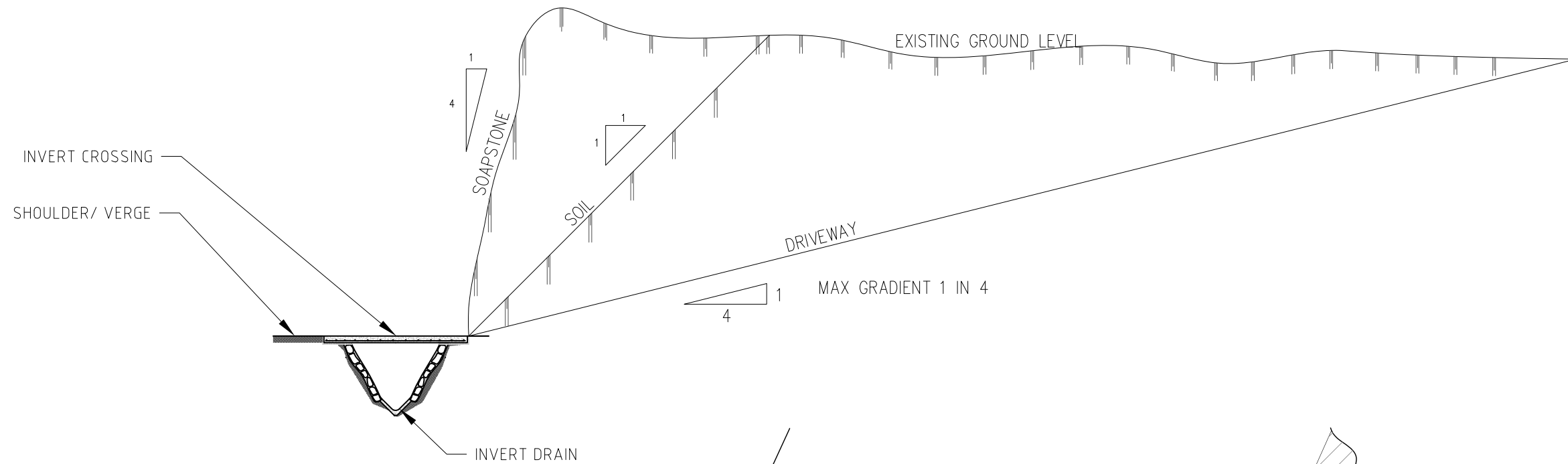

A3 ORIGINAL SIZE

ISSUE	APPD	DATE	AMENDMENT	BY
E				
D				
C				
B				
A				

GENERAL NOTES

**STANDARD DRAWINGS**  
**TYPICAL DRIVEWAY IN CUT**  
**ACCESSWAY DETAILS**

SCALE: \_\_\_\_\_ DATE: 01 MAY 17 DESIGN BY: \_\_\_\_\_



**Fiji Roads Authority**

DRAWN BY CWS	APPROVED A KETENILAGI	DRAWING No. R 504 - 8	SHEET No. 01	ISSUE A
-----------------	--------------------------	--------------------------	-----------------	------------

A3 ORIGINAL SIZE  
10  
20  
30  
40  
50  
100  
150  
PLOT DATE 18/10/2018

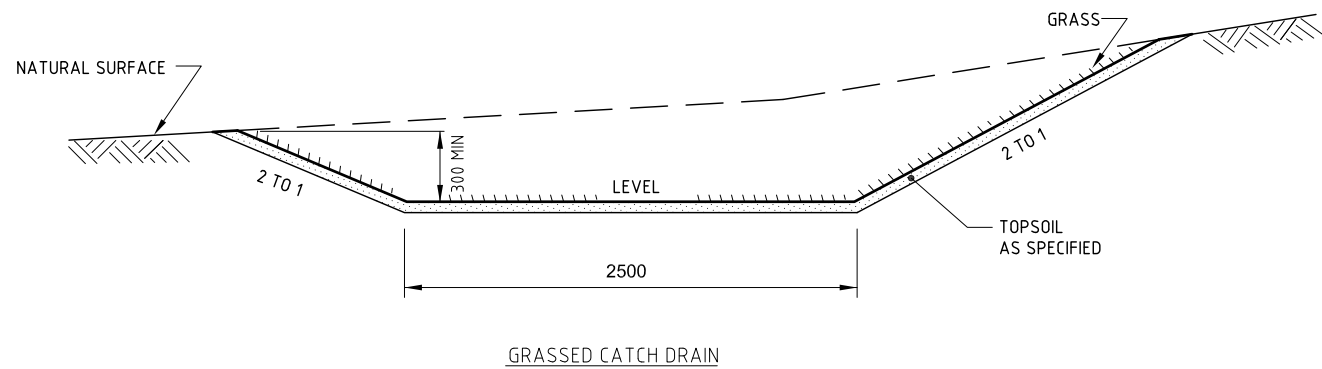

GRASSED CATCH DRAIN

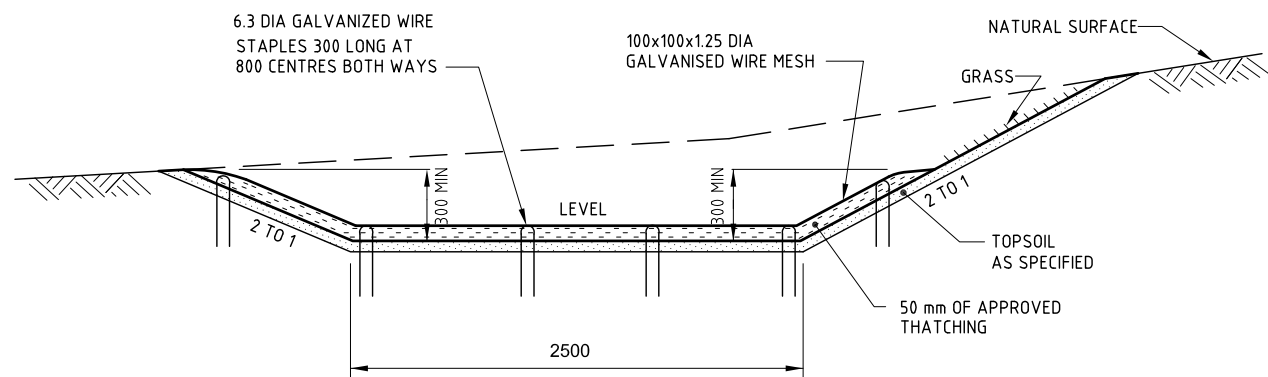

THATCHED CATCH DRAIN

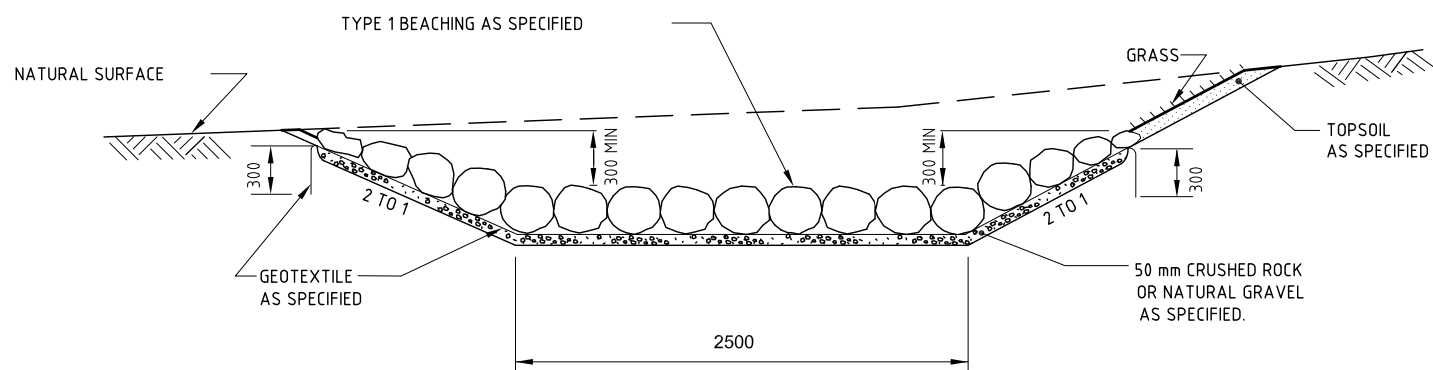

BEACHED CATCH DRAIN

NOTES:

1. CATCH DRAINS SHALL BE CONSTRUCTED WHERE INDICATED ON ALIGNMENT PLANS.
2. CATCH DRAINS SYMBOLS SHOWN ON THE ALIGNMENT PLANS:  

GRASSED	→	→
THATCHED	→ T →	→
BEACHED	→ B →	→
3. CATCH DRAINS SHALL BE GRADED TO CULVERTS, DRAINAGE PITS OR EXISTING LOW POINTS.
4. CATCH DRAINS SHALL BE LINED WITH TOPSOIL AS SHOWN.

E			
D			
C			
B			
A			
ISSUE	APPD	DATE	AMENDMENT
			BY

GENERAL NOTES  
1. ALL DIMENSIONS ARE IN MILLIMETERS

STANDARD DRAWINGS  
TYPICAL CATCH DRAIN  
TYPE A

SCALE	DATE	DESIGN BY
	01 MAY 17	

DRAWN BY	APPROVED	DRAWING No.	SHEET No.	ISSUE
CWS	A KETENILAGI	R 504 - 9	01	A

A3 ORIGINAL SIZE

10 20 30 40 50

150 PLOT DATE 19/10/2018

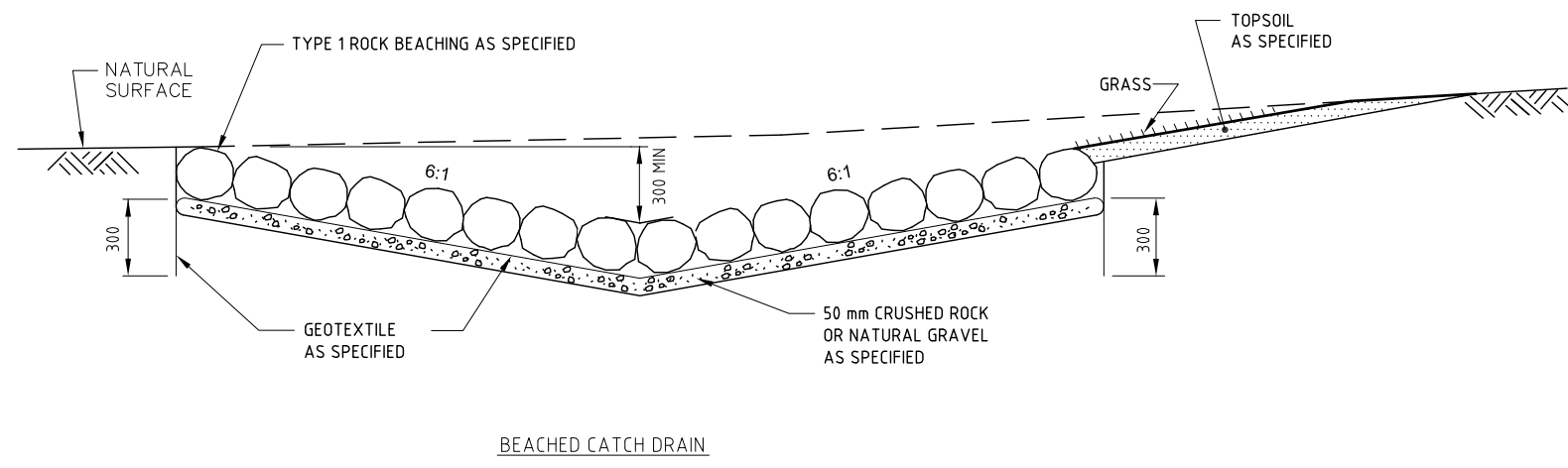
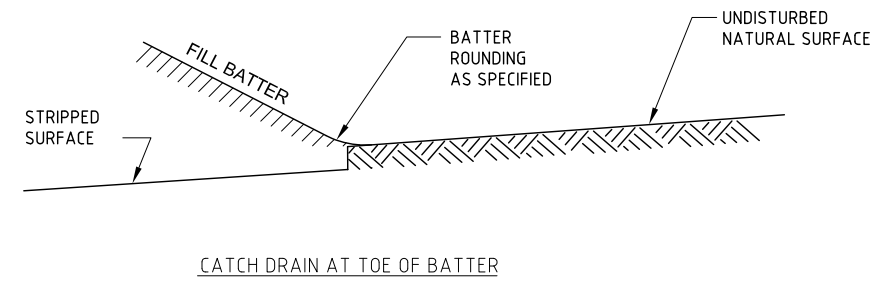
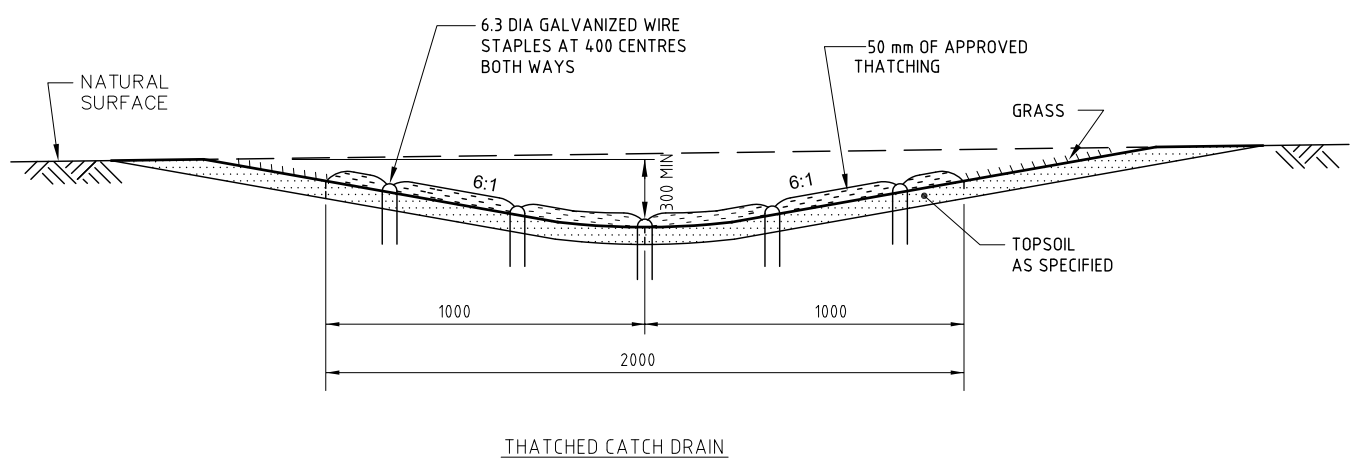
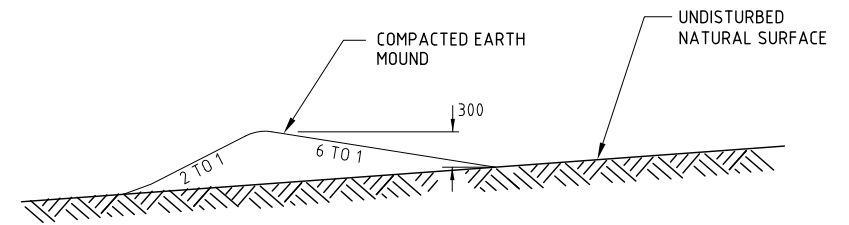
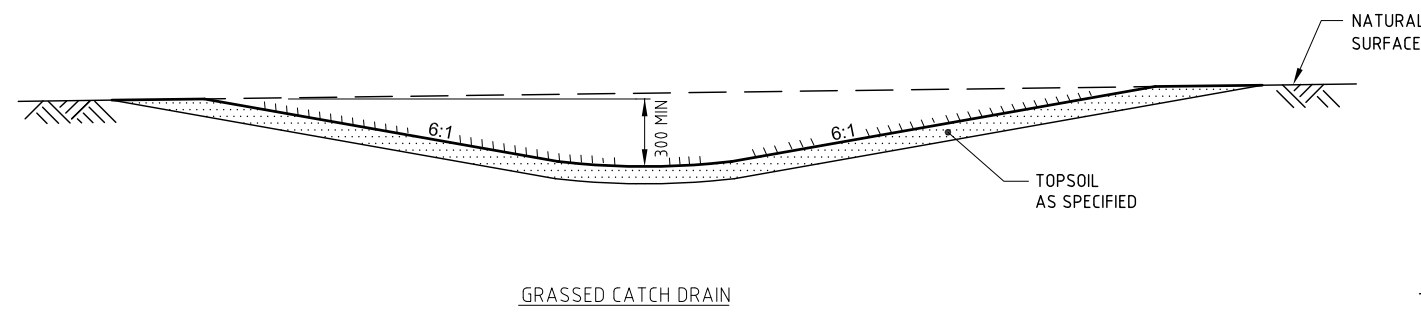

- NOTES:**
- CATCH DRAINS SHALL BE CONSTRUCTED WHERE INDICATED ON ALIGNMENT PLANS.  
 PLANS: GRASSED → →  
 THATCHED → T →  
 BEACHED → B →  
 MOUNDED → M →  
 AT TOE OR BATTER → E →
  - CATCH DRAIN SYMBOLS ON ALIGNMENT PLANS SHOWN THUS :
  - CATCH DRAINS SHALL BE GRADED TO CULVERTS OR EXISTING LOW POINTS.
  - CATCH DRAINS SHALL BE LINED WITH TOPSOIL AS SHOWN.

E				
D				
C				
B				
A				
ISSUE	APPD	DATE	AMENDMENT	BY

GENERAL NOTES

**STANDARD DRAWINGS**  
TYPICAL CATCH DRAIN  
TYPE B

SCALE	DATE	DESIGN BY	DRAWN BY	APPROVED	DRAWING No.	SHEET No.	ISSUE
	01 MAY 17		CWS	A KETENILAGI	R 504 - 10	01	A



Fiji Roads Authority

PLOT DATE 31/07/2019

150

100

50

40

30

20

10

A3 ORIGINAL SIZE

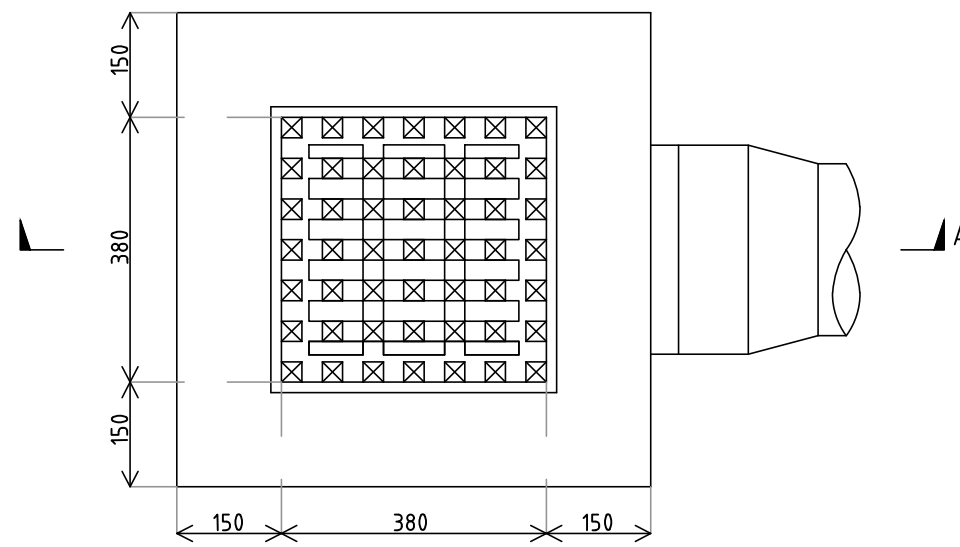

PLAN

TOP OF GRATING 15mm BELOW CHANNEL INVERT OR GRASS AREAS FOR FLUSH WITH ROAD SURFACE WHERE USED IN ROADWAY.

FINISHED SUMP TOP LEVELS ON PLAN GIVEN TO THIS POINT.

STANDARD TYPE GRATING EITHER SOLID PLATE HOLES FOR DRAINAGE AS SPECIFIED.

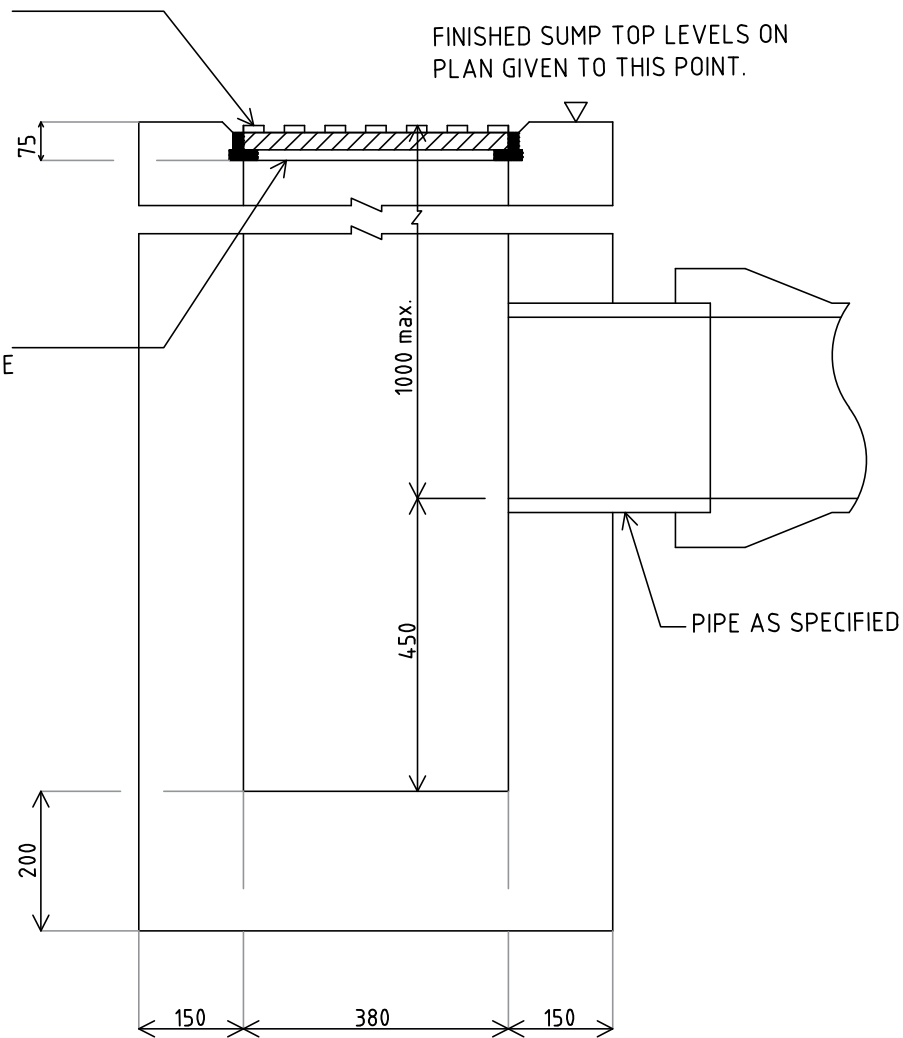

SECTION A-A

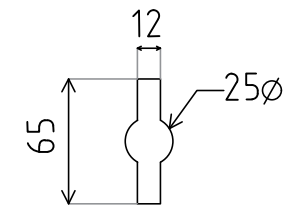

KEYWAY FOR SOLID PLATE

ISSUE	APPD	DATE	AMENDMENT	BY
E				
D				
C				
B				
A				

GENERAL NOTES

STANDARD DRAWINGS		
TYPE C GRASSED CATCH - DRAIN CATCH PIT		
SCALE	DATE 30 MAR 17	DESIGN BY

 <b>Fiji Roads Authority</b>				
DRAWN BY CWS	APPROVED	DRAWING No. R 504 - 11	SHEET No. 01	ISSUE A

# INDEX SHEET

## SERIES 601 INCIDENTAL CONSTRUCTION DETAILS

DRAWING NUMBER	DRAWING TITLE
R 601 - 1	TYPICAL KERB RAMP DETAIL
R 601 - 2	TYPICAL CONSTRUCTION JOINT DETAIL
R 601 - 3	TYPICAL BUS BAY DIMENSIONS
R 601 - 4	TYPICAL CONCRETE BUS BAY DETAILS
R 601 - 5	TYPICAL CONCRETE BUS BAY DETAILS
R 601 - 6	TYPICAL STANDARD FOOTPATH CROSSING – LIGHT VEHICLES
R 601 - 7	TYPICAL STANDARD FOOTPATH CROSSING – HEAVY VEHICLES
R 601 - 8	TRUCK ACCESS TO RURAL PROPERTIES TYPE A
R 601 - 9	TRUCK ACCESS TO RURAL PROPERTIES TYPE B
R 601 - 10	TYPICAL RURAL DRIVEWAY ACCESS TO RESIDENTIAL PROPERTIES TYPE C
R 601 - 11	TYPICAL STANDARD BUS SHELTER TYPE 1
R 601 - 12	TYPICAL STANDARD BUS SHELTER TYPE 2 – HUMES DESIGN

---

PLOT DATE 12/03/2019

150  
100  
50  
40  
30  
20  
10

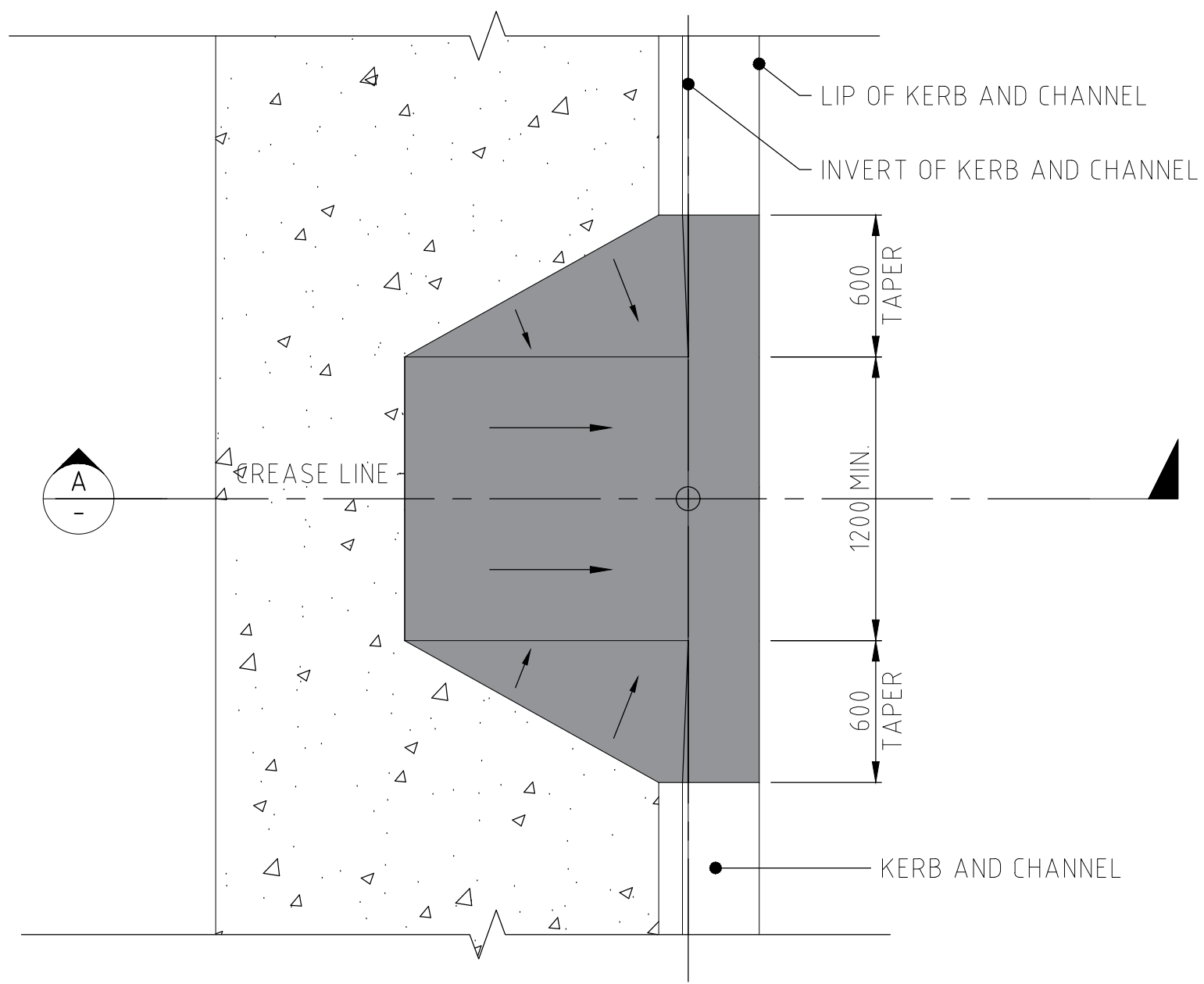

TYPICAL PRAM RAMP LAYOUT  
SCALE 1:25

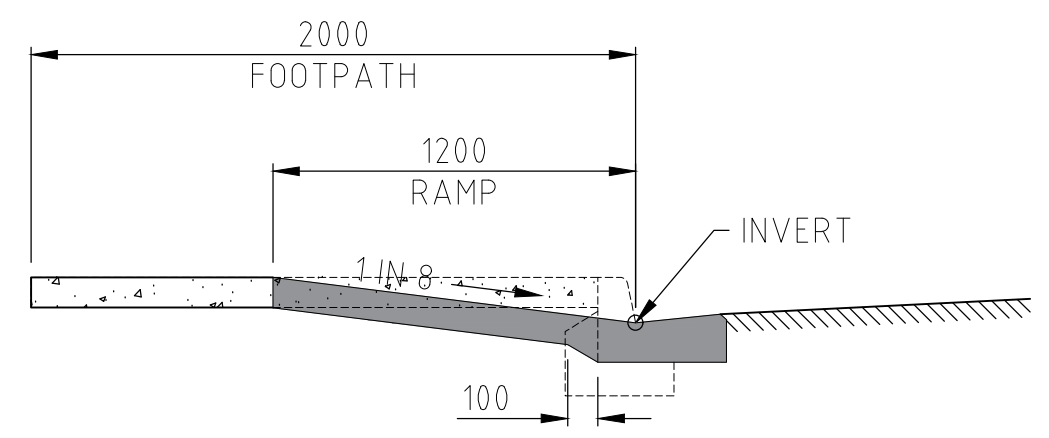

SECTION A-A  
SCALE 1:25

A3 ORIGINAL SIZE	E				
	D				
	C				
	B				
	A				
ISSUE	APP'D	DATE	AMENDMENT	BY	

GENERAL NOTES  
1. The maximum slope change at each face shall be no greater than 1 in 8

SCALE		DATE	DESIGN BY	DRAWN BY	APPROVED	DRAWING No.	SHEET No.	ISSUE
		05 April 17		CWS		R 601 - 1	01	

STANDARD DRAWINGS  
TYPICAL KERB RAMP  
DETAILS



PLOT DATE 19/10/2018

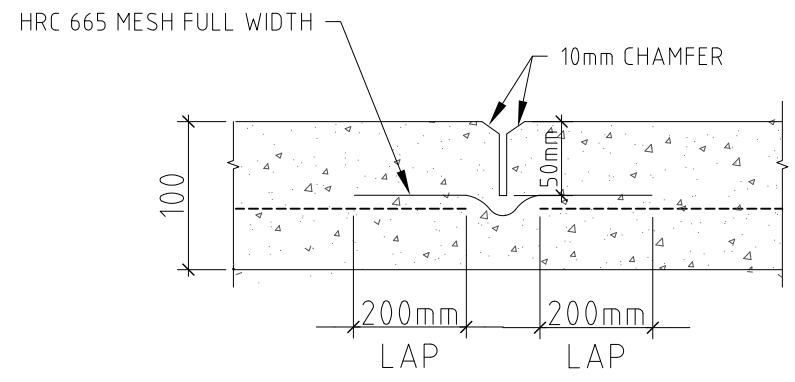

**SAW CUT JOINT (FOOTPATH)**  
SCALE 1 : 5

**NOTE**  
ALL JOINTS BETWEEN THE EXISTING AND NEW FOOTPATHS SHALL BE SAW CUT TO A STRAIGHT LINE. RAGGED EDGES WILL NOT BE ACCEPTED BY THE ENGINEER AND SHALL BE MADE GOOD AT THE CONTRACTOR'S EXPENSE.

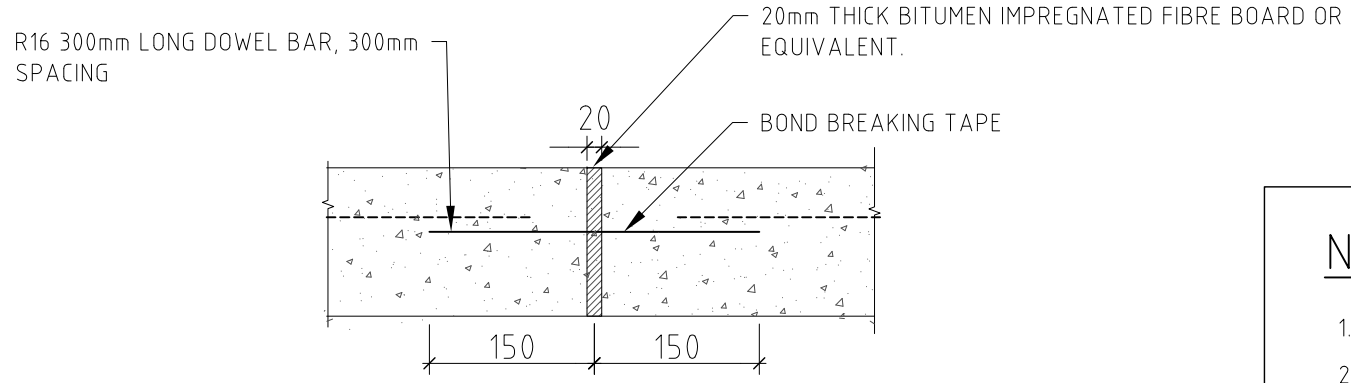

**CONSTRUCTION JOINT DETAIL (FOOTPATH)**  
SCALE 1 : 5

- NOTES:**
1. ALL CONCRETE TO BE 20 MP<sub>a</sub> UNO.
  2. DESIRABLE GRADE IS BETWEEN 1 IN 8 AND 1 IN 12 INCLUSIVE.
  3. EDGE OF CROSSING TO HAVE 35mm LIP WITH EXISTING CHANNEL
  4. RESIDENTIAL CROSSINGS SERVING A SINGLE DWELLING TO BE 100mm THICK MINIMUM.
  5. COMMERCIAL /LIGHT INDUSTRIAL CROSSINGS TO BE 180mm THICK WITH THREE D12 RODS IN DISHED KERB AND CHANNELS,
  6. FOR COMMERCIAL ACCESS MODIFY ACCESS SPLAY LOCALLY TO ACCOMMODATE ANGLED LEFT TURN OUT/TURN IN AS APPLICABLE.

A3 ORIGINAL SIZE	E				
	D				
	C				
	B				
	A				
ISSUE	APPD	DATE	AMENDMENT	BY	

GENERAL NOTES

<b>STANDARD DRAWINGS</b>	
<b>TYPICAL CONSTRUCTION JOINT DETAILS</b>	
SCALE	DATE
	05 April 17

<b>Fiji Roads Authority</b>				
DRAWN BY	APPROVED	DRAWING No.	SHEET No.	ISSUE
CWS		R 601 - 2	01	

PLOT DATE 19/10/2018

150  
100  
50  
40  
30  
20  
10

STANDARD BUS BAY

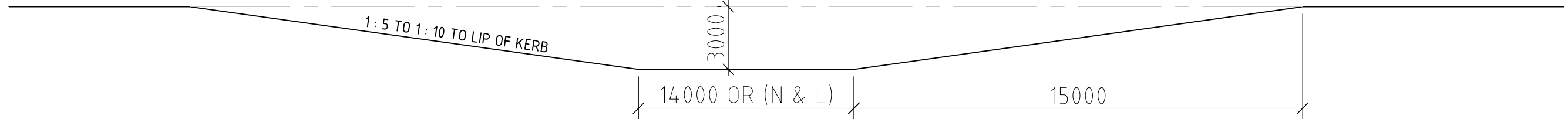

SINGLE BUS BAY

NOTE:  
 • REFER ARGD PART 3, SECTION 4.12 FOR DETAIL DESIGN.  
 N = NUMBER OF BUSES THAT STOP SIMULTANEOUSLY  
 L = LENGTH OF BUS ( INCLUDING CLEARANCES IF DESIRED)

A3 ORIGINAL SIZE	E			
	D			
	C			
	B			
	A			
ISSUE	APPD	DATE	AMENDMENT	BY

GENERAL NOTES

STANDARD DRAWINGS	
STANDARD BUS BAY DIMENSIONS	
SCALE	DATE
	05 April 17

 <b>Fiji Roads Authority</b>		DRAWING No.	SHEET No.	ISSUE
		R 601 - 3	01	
DRAWN BY	APPROVED	DRAWING No.	SHEET No.	ISSUE
CWS		R 601 - 3	01	

PLOT DATE 19/10/2018

150  
100  
50  
40  
30  
20  
10

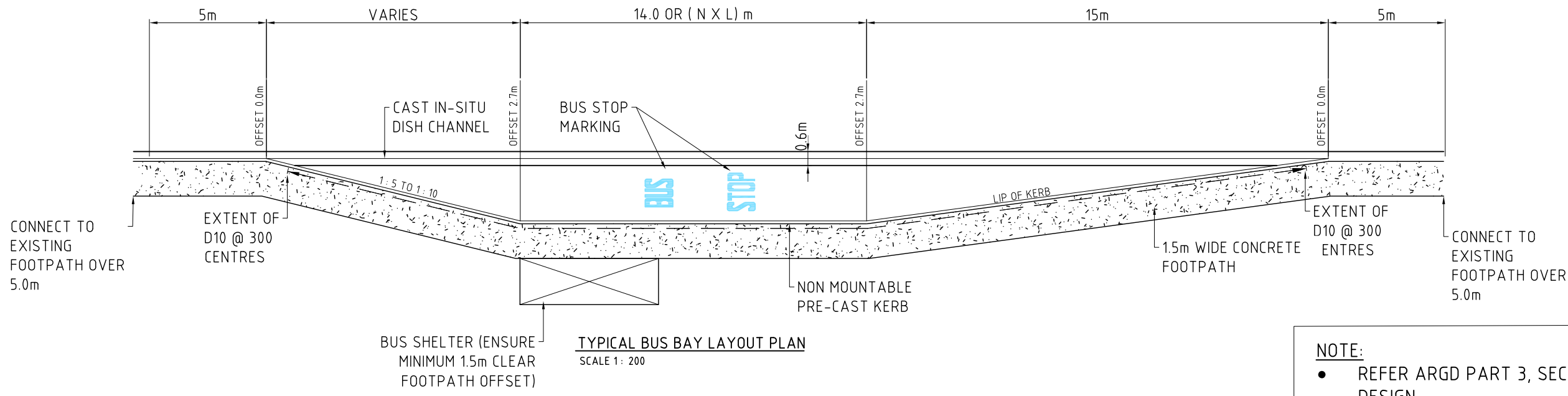

**NOTE:**

- REFER ARGD PART 3, SECTION 4.12 FOR DETAIL DESIGN.

N = NUMBER OF BUSES THAT STOP SIMULTANEOUSLY

L = LENGTH OF BUS (INCLUDING CLEARANCES IF DESIRED)

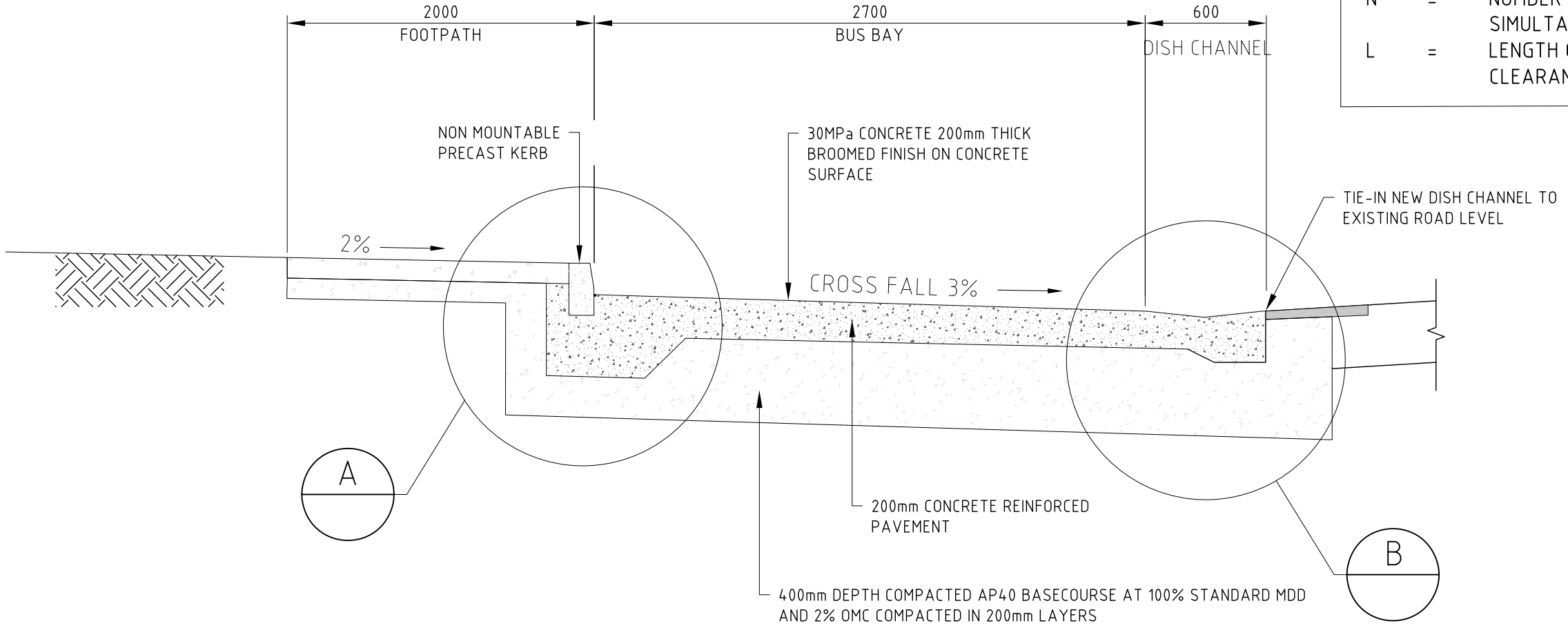

TYPICAL CROSS SECTION

A3 ORIGINAL SIZE	E			
	D			
	C			
	B			
	A			
ISSUE	APPD	DATE	AMENDMENT	BY

GENERAL NOTES

STANDARD DRAWINGS  
STANDARD CONCRETE  
BUS BAY DETAILS

SCALE: DATE: 05 April 17 DESIGN BY: DRAWN BY: CWS APPROVED: DRAWING No. R 601 - 4 SHEET No. 01 ISSUE

Fiji Roads Authority

PLOT DATE 12/03/2019

150

100

50

40

30

20

10

A3 ORIGINAL SIZE

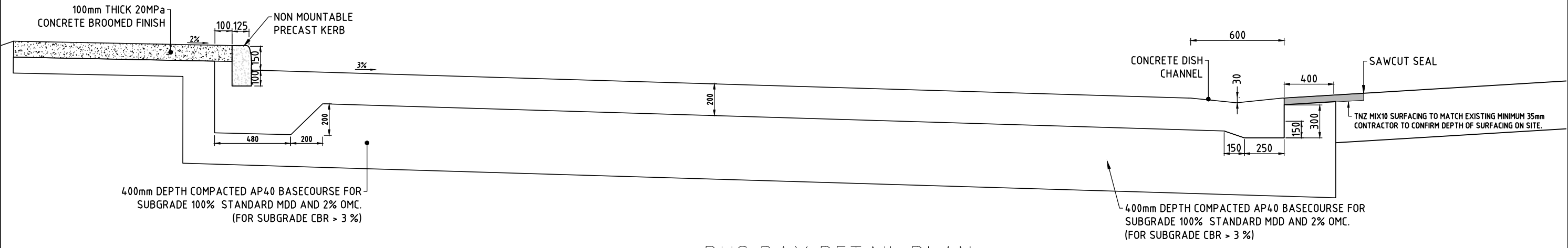

### BUS BAY DETAIL PLAN

SCALE 1: 25

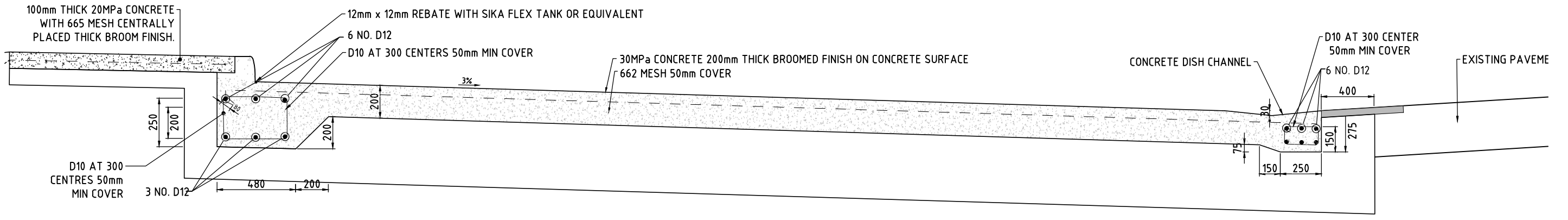

### RE INFORCEMENT DETAIL

SCALE 1: 25

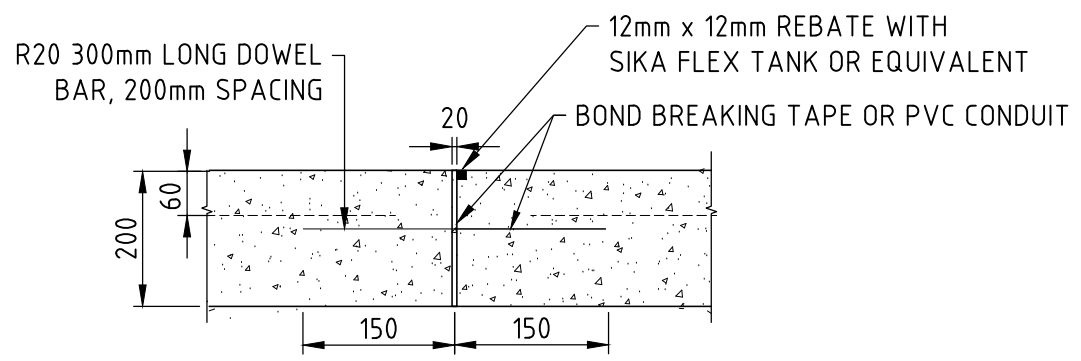

### CONSTRUCTION JOINT DETAIL

NOTES:

1. KERB BLOCKS TO BE NEATLY JOINTED WITH 10mm MINIMUM CEMENT MORTAR.
2. CONSTRUCTION OR CONTROL JOINTS AT APPROXIMATELY 5 TO 6 m SPACING AND SAW CUTS AT CORNERS.
3. ALL STEEL REINFORCING TO BE IN ACCORDANCE WITH AS/NZS 4671:2001, STEEL REINFORCING MATERIALS.

ISSUE	APP'D	DATE	AMENDMENT	BY
E				
D				
C				
B				
A				

GENERAL NOTES

STANDARD DRAWINGS			
STANDARD CONCRETE			
BUS BAY DETAILS			
SCALE	DATE	DESIGN BY	DRAWN BY
	05 April 17		CWS

Fiji Roads Authority

DRAWING No.	R 601 - 5	SHEET No.	01	ISSUE	
-------------	-----------	-----------	----	-------	--

# CONCRETE FOOTPATH CROSSING

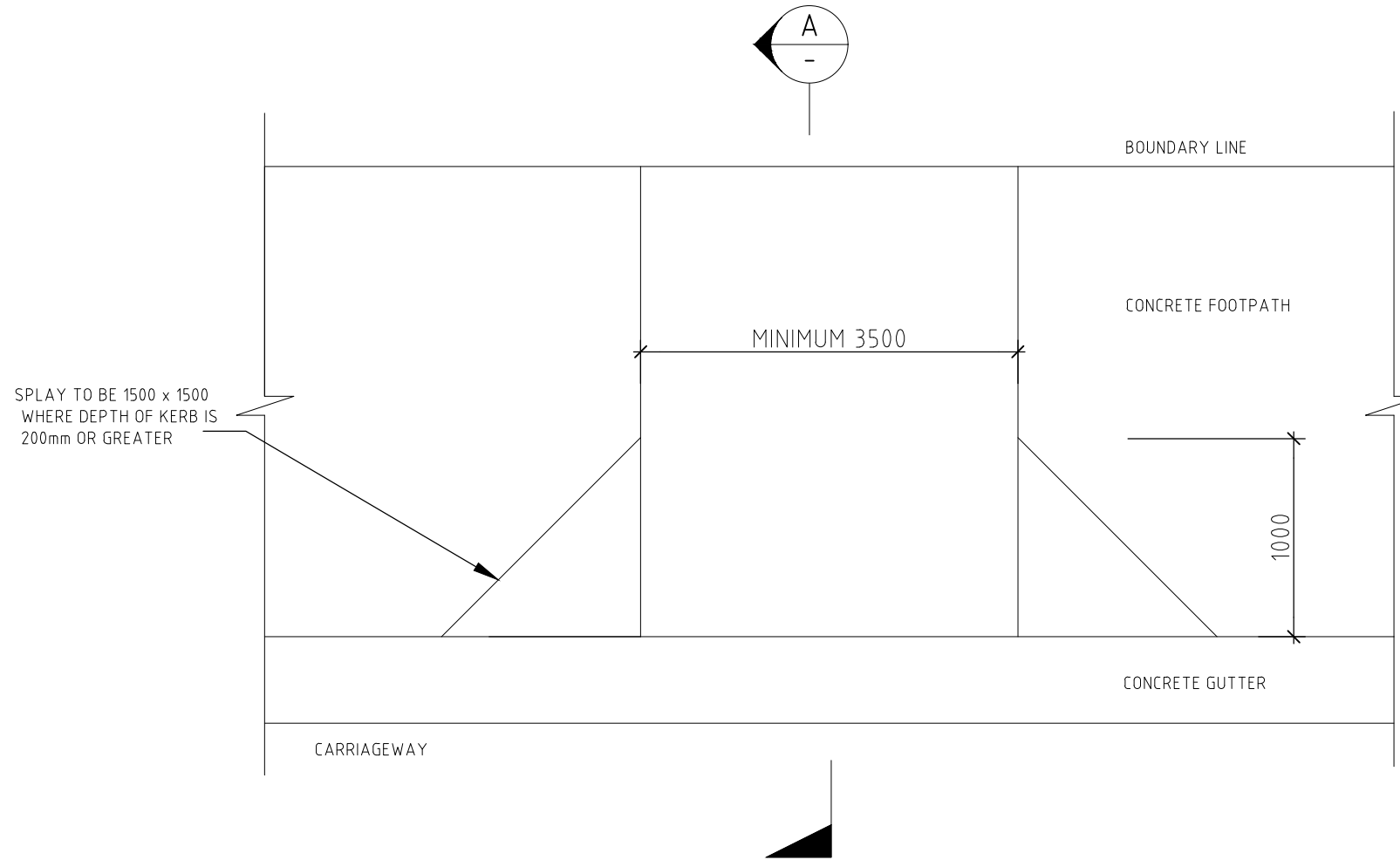
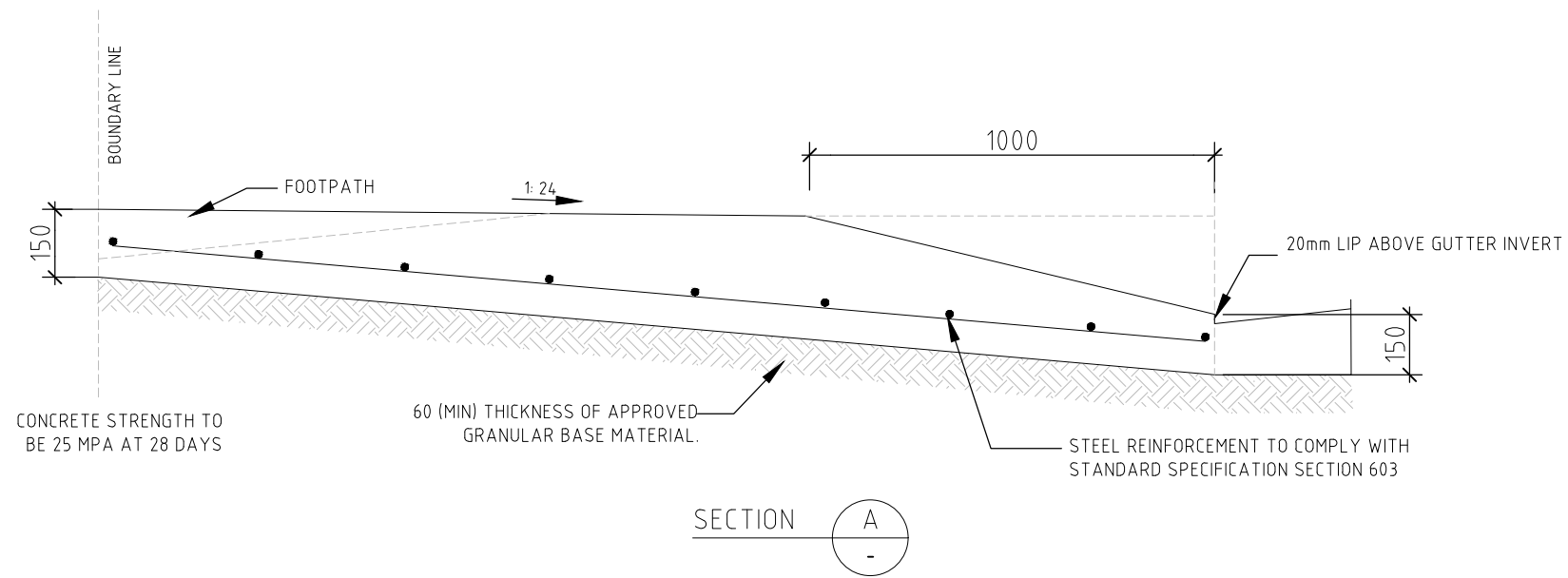

**NOTE**

- CONCRETE STRENGTH TO BE 25MP<sub>a</sub> AT 28 DAYS

**PLAN**

PLOT DATE 20/03/2019



ISSUE	APP'D	DATE	AMENDMENT	BY
E				
D				
C				
B				
A				

GENERAL NOTES

STANDARD DRAWINGS			
STANDARD FOOTPATH CROSSING			
LIGHT VEHICLES			
SCALE	DATE	DESIGN BY	DRAWN BY
	05 April 17		CWS

Fiji Roads Authority

DRAWN BY	APPROVED	DRAWING No.	SHEET No.	ISSUE
CWS		R 601 - 6	01	

# CONCRETE FOOTPATH CROSSING FOR HEAVY VEHICLES

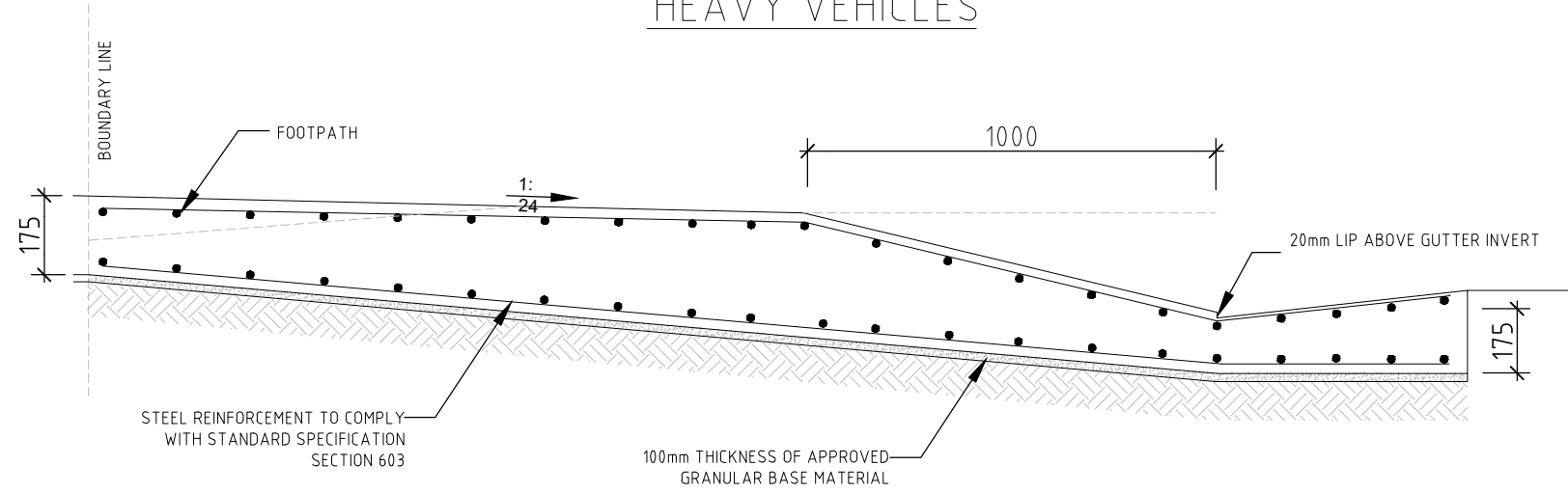

**NOTE**  
CONCRETE STRENGTH TO BE 25MPa AT 28 DAYS

SECTION A

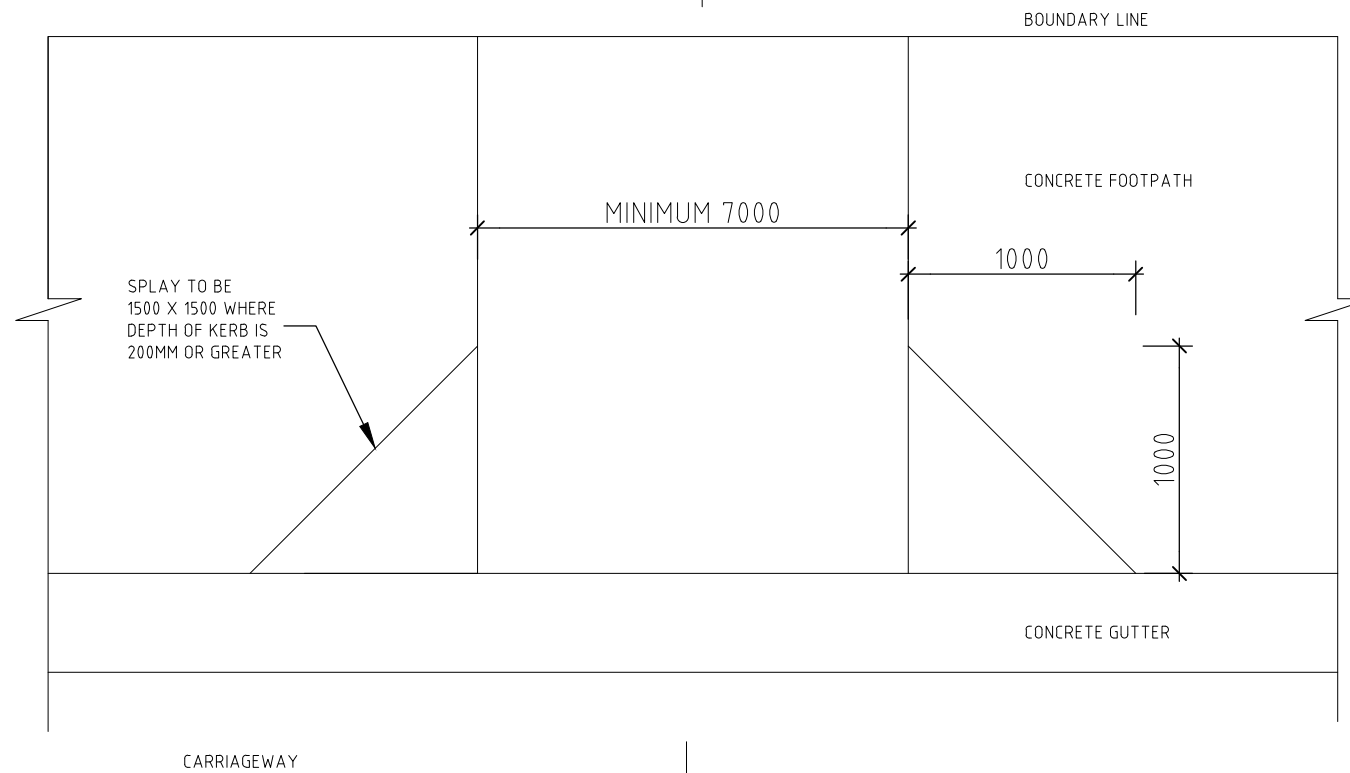
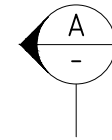

**PLAN**

PLOT DATE 12/03/2019

150

100

50

40

30

20

10

A3 ORIGINAL SIZE

ISSUE	APP'D	DATE	AMENDMENT	BY
E				
D				
C				
B				
A				

GENERAL NOTES

<b>STANDARD DRAWINGS</b>			
<b>STANDARD FOOTPATH CROSSING HEAVY VEHICLES</b>			
SCALE	DATE	DESIGN BY	DRAWN BY
	05 April 17		CWS

**Fiji Roads Authority**

APPROVED	DRAWING No.	SHEET No.	ISSUE
	R 601 - 7	01	

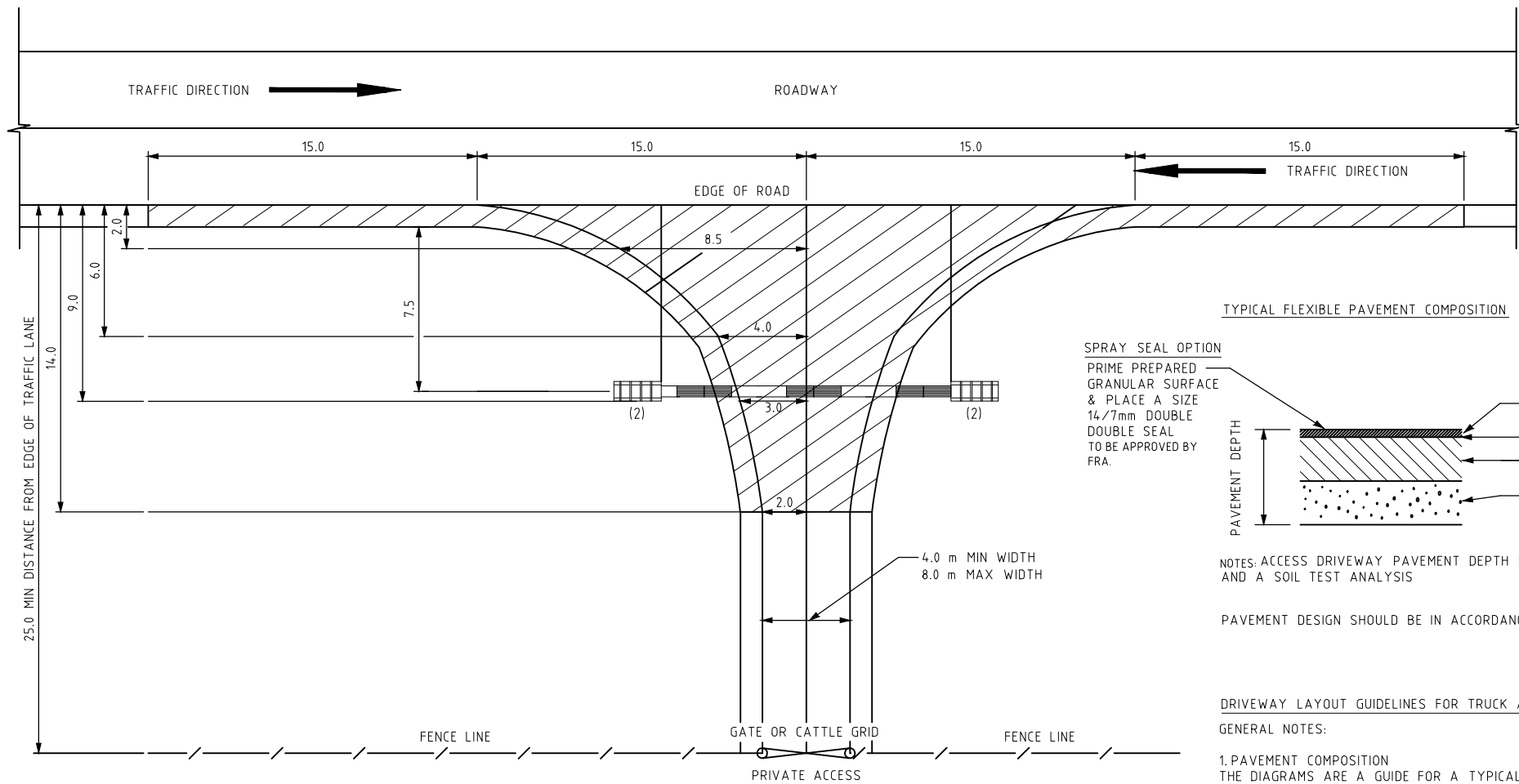

PLAN - DRIVEWAY ACCESS LAYOUT

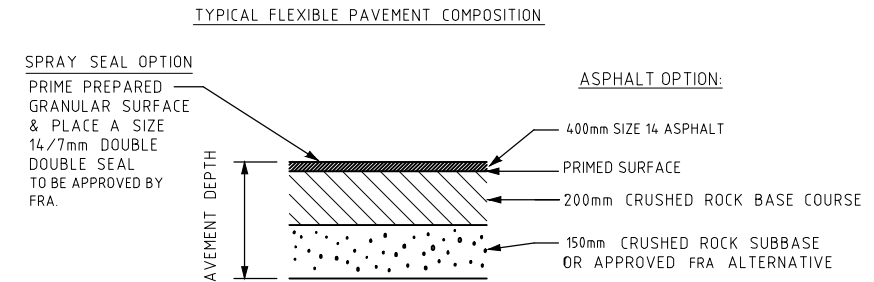

NOTES: ACCESS DRIVEWAY PAVEMENT DEPTH SHOULD BE DETERMINED FROM EXISTING PAVEMENT AND A SOIL TEST ANALYSIS

PAVEMENT DESIGN SHOULD BE IN ACCORDANCE WITH FRA DESIGN SUPPLEMENT

**DRIVEWAY LAYOUT GUIDELINES FOR TRUCK ACCESS**

**GENERAL NOTES:**

1. PAVEMENT COMPOSITION THE DIAGRAMS ARE A GUIDE FOR A TYPICAL LAYOUT OF A DRIVEWAY ACCESS FOR A RURAL PROPERTY FOR THE DESIGN VEHICLE LISTED. THIS GUIDE WAS DEVELOPED IN THE INTEREST OF ROAD SAFETY AND TO PROTECT THE ROAD PAVEMENT AT THE ACCESS LOCATION. FINAL PAVEMENT COMPOSITION SHOULD BE DETERMINED BY EXISTING PAVEMENT AND SOIL TESTS, AND APPROVED BY FRA.
2. A PLANNING PERMIT IS REQUIRED FOR A NEW ACCESS OR ALTERATION TO AN EXISTING DRIVEWAY AND MAY BE REQUIRED FOR THE REMOVAL OF NATIVE VEGETATION.
3. TRUCK WARNING SIGNS & GUIDE POSTS SHOULD BE INSTALLED
4. THE DRIVEWAY ACCESS CONSTRUCTION AND MAINTENANCE IS THE RESPONSIBILITY OF THE PROPERTY OWNER. MAINTENANCE ALSO INCLUDES ASSOCIATED DRAINAGE WORKS.

**SIGHT DISTANCE**

THE TRUCK DRIVER WHEN LOCATED 3m FROM THE EDGE OF THE TRAFFIC LANE NEEDS TO BE ABLE TO SEE A VEHICLE APPROACHING IN EITHER DIRECTION WHEN EXITING FROM A DRIVEWAY. REFER TO TABLE 1 FOR APPROPRIATE SIGHT DISTANCES. TREE CANOPIES, BUSHES OR OTHER OBJECTS SHALL BE REMOVED TO PROVIDE GOOD VISIBILITY AND TO PREVENT TRUCK DAMAGE. ANY TREE CANOPIES OVERHANGING THE PATH OF A TRUCK SHALL BE A MINIMUM OF 5m ABOVE THE GROUND SURFACE.

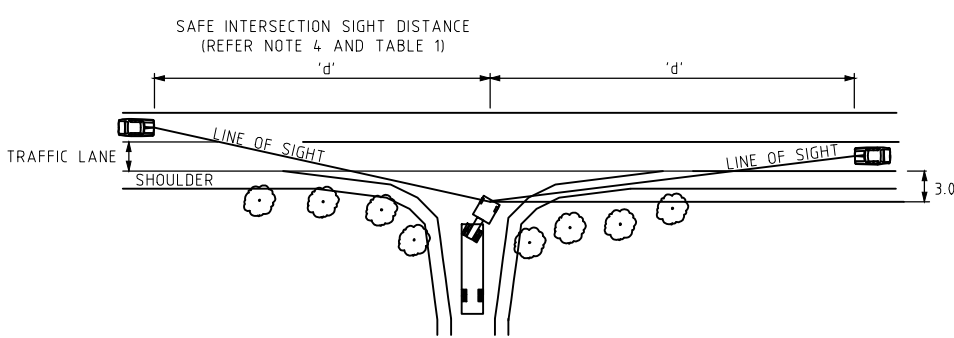

TABLE 1

DESIGN SPEED (Km/h)	'd' SAFE INTERSECTION SIGHT DISTANCE (m)
60	123
70	151
80	181

ISSUE	APPD	DATE	AMENDMENT	BY
E				
D				
C				
B				
A				

**GENERAL NOTES**

1. ALL DIMENSION ARE IN METERS
2. STANDARD WINGWALL END UNITS MAY BE ADOPTED WITH FRA APPROVAL

**STANDARD DRAWINGS**

**TRUCK ACCESS TO RURAL PROPERTIES**

**TYPE A**

SCALE	DATE	DESIGN BY	DRAWN BY	APPROVED	DRAWING No.	SHEET No.	ISSUE
	05 April 17		CWS		R 601 - 8	01	

**Fiji Roads Authority**

PLOT DATE 12/03/2019

150

100

50

40

30

20

10

A3 ORIGINAL SIZE

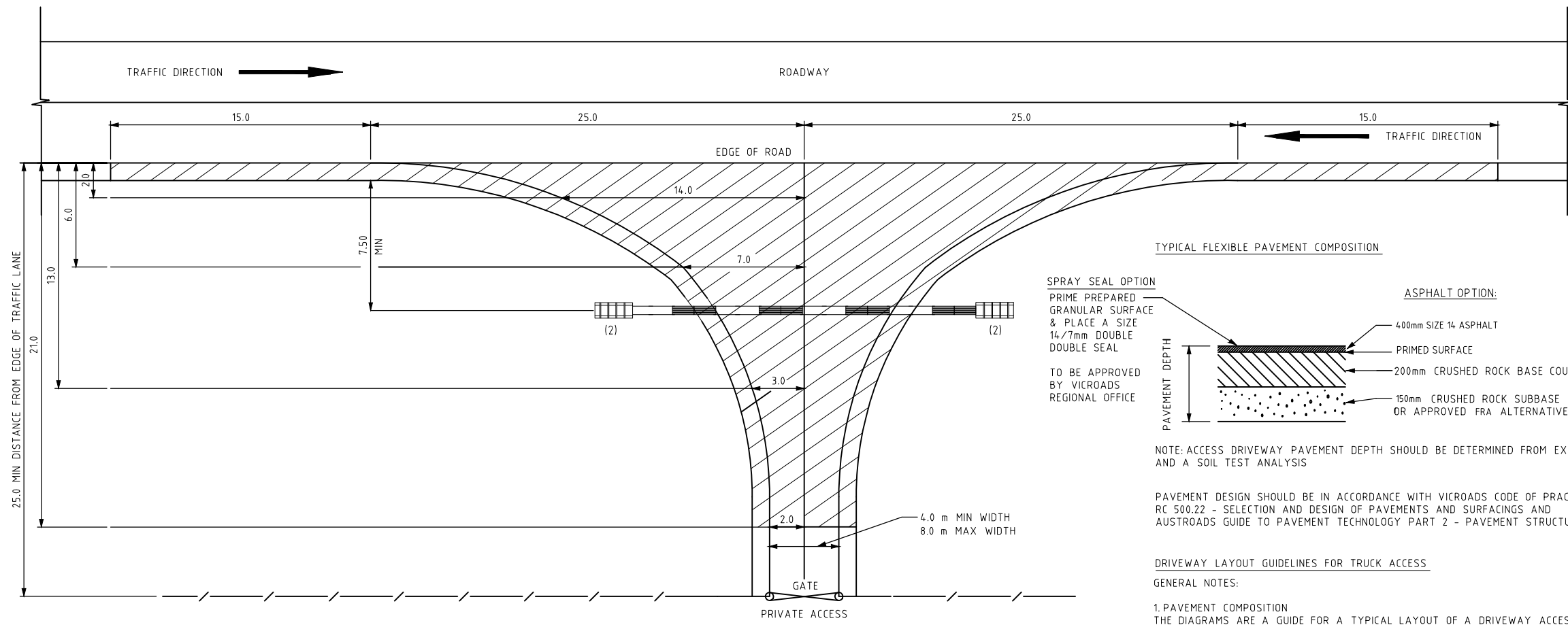

PLAN - DRIVEWAY ACCESS LAYOUT

TYPICAL FLEXIBLE PAVEMENT COMPOSITION

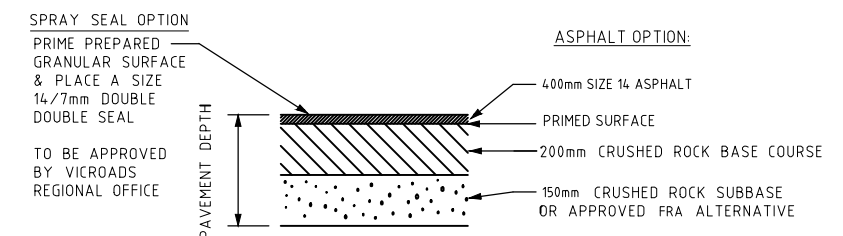

NOTE: ACCESS DRIVEWAY PAVEMENT DEPTH SHOULD BE DETERMINED FROM EXISTING PAVEMENT AND A SOIL TEST ANALYSIS

PAVEMENT DESIGN SHOULD BE IN ACCORDANCE WITH VICROADS CODE OF PRACTICE RC 500.22 - SELECTION AND DESIGN OF PAVEMENTS AND SURFACINGS AND AUSTRROADS GUIDE TO PAVEMENT TECHNOLOGY PART 2 - PAVEMENT STRUCTURAL DESIGN.

DRIVEWAY LAYOUT GUIDELINES FOR TRUCK ACCESS

GENERAL NOTES:

1. PAVEMENT COMPOSITION THE DIAGRAMS ARE A GUIDE FOR A TYPICAL LAYOUT OF A DRIVEWAY ACCESS FOR A RURAL PROPERTY FOR THE DESIGN VEHICLE LISTED. THIS GUIDE WAS DEVELOPED IN THE INTEREST OF ROAD SAFETY AND TO PROTECT THE ROAD PAVEMENT AT THE ACCESS LOCATION. FINAL PAVEMENT COMPOSITION SHOULD BE DETERMINED BY EXISTING PAVEMENT AND SOIL TESTS, AND APPROVED BY VICROADS REGIONAL OFFICE.
2. A PLANNING PERMIT IS REQUIRED FOR A NEW ACCESS OR ALTERATION TO AN EXISTING DRIVEWAY AND MAY BE REQUIRED FOR THE REMOVAL OF NATIVE VEGETATION.
3. TRUCK WARNING SIGNS & GUIDE POSTS SHOULD BE INSTALLED IN ACCORDANCE WITH VICROADS TRAFFIC ENGINEERING MANUAL VOLUME 2 CHAPTER 9.
4. THE DRIVEWAY ACCESS CONSTRUCTION AND MAINTENANCE IS THE RESPONSIBILITY OF THE PROPERTY OWNER. MAINTENANCE ALSO INCLUDES ASSOCIATED DRAINAGE WORKS.

SIGHT DISTANCE

THE TRUCK DRIVER WHEN LOCATED 3m FROM THE EDGE OF THE TRAFFIC LANE NEEDS TO BE ABLE TO SEE A VEHICLE APPROACHING IN EITHER DIRECTION WHEN EXITING FROM A DRIVEWAY. REFER TO TABLE 1 FOR APPROPRIATE SIGHT DISTANCES. TREE CANOPIES, BUSHES OR OTHER OBJECTS SHALL BE REMOVED TO PROVIDE GOOD VISIBILITY AND TO PREVENT TRUCK DAMAGE. ANY TREE CANOPIES OVERHANGING THE PATH OF A TRUCK SHALL BE A MINIMUM OF 5m ABOVE THE GROUND SURFACE.

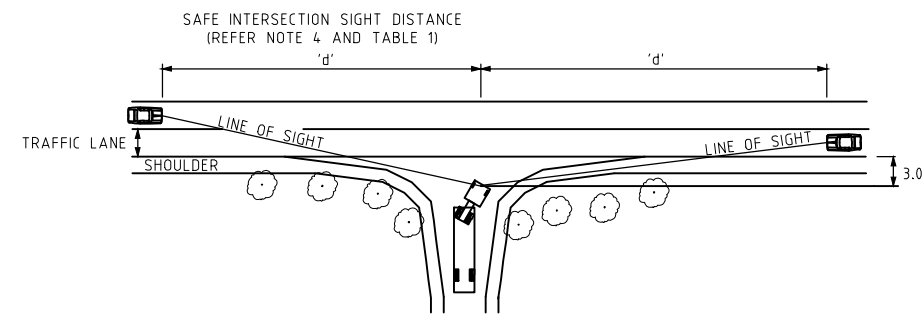

MINIMUM VISIBILITY REQUIREMENTS (NOT TO SCALE)

TABLE 1

DESIGN SPEED (Km/h)	'd' SAFE INTERSECTION SIGHT DISTANCE (m)
60	123
70	151
80	181

GENERAL NOTES

1. ALL DIMENSIONS ARE IN METERS
2. STANDARD WINGWALL END UNITS MAY BE ADOPTED WITH FRA APPROVAL

STANDARD DRAWINGS

TRUCK ACCESS TO RURAL PROPERTIES  
TYPE B



ISSUE	APP'D	DATE	AMENDMENT	BY
E				
D				
C				
B				
A				

SCALE	DATE	DESIGN BY	DRAWN BY	APPROVED	DRAWING No.	SHEET No.	ISSUE
	05 April 17		CWS		R 601 - 9	01	

PLOT DATE 12/03/2019

150

100

50

40

30

20

10

A3 ORIGINAL SIZE

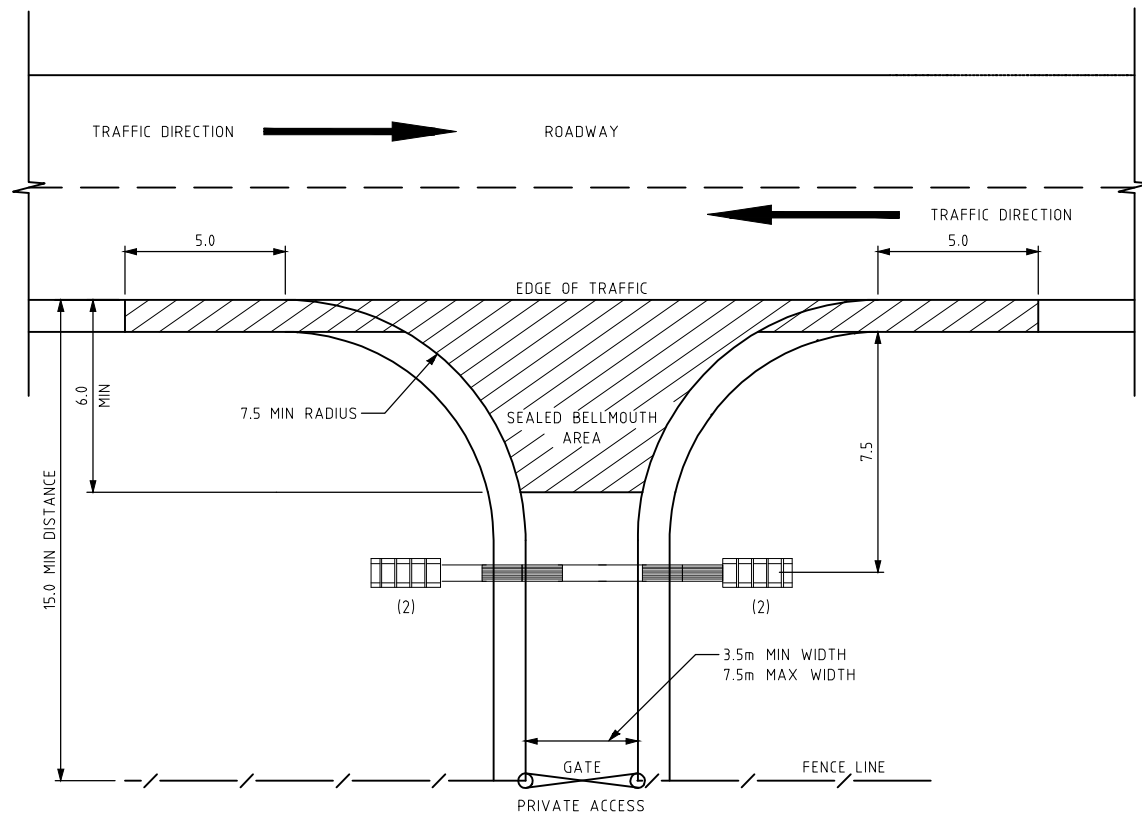

PLAN - TYPICAL DRIVEWAY ACCESS

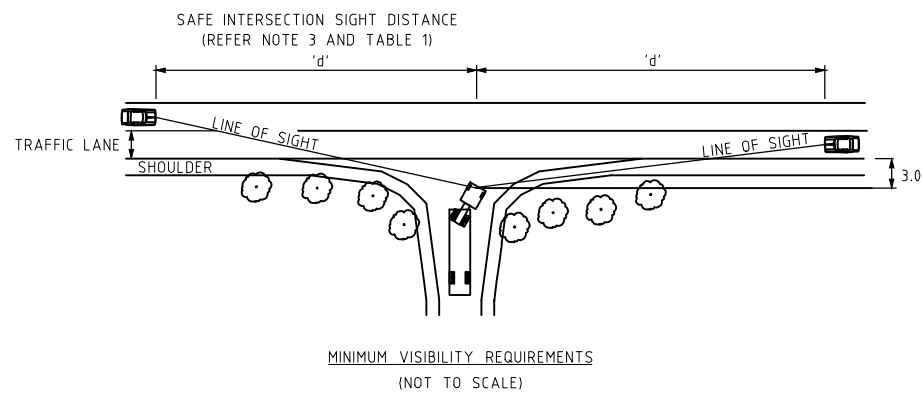

MINIMUM VISIBILITY REQUIREMENTS (NOT TO SCALE)

TABLE 1

DESIGN SPEED (Km/h)	'd' SAFE INTERSECTION SIGHT DISTANCE (m)
60	123
70	151
80	181

TYPICAL FLEXIBLE PAVEMENT COMPOSITION

SPRAY SEAL OPTION  
PRIME PREPARED GRANULAR SURFACE & PLACE A SIZE 14/7mm DOUBLE SEAL  
TO BE APPROVED BY VICROADS REGIONAL OFFICE

ASPHALT OPTION:

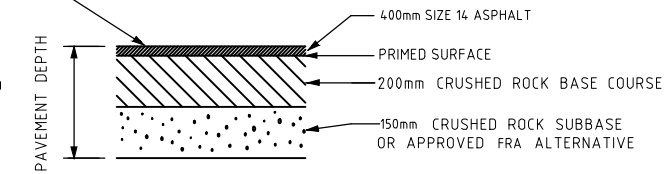

NOTE: ACCESS DRIVEWAY PAVEMENT DEPTH SHOULD BE DETERMINED FROM EXISTING PAVEMENT AND A SOIL TEST ANALYSIS

RIGID PAVEMENT OPTIONS

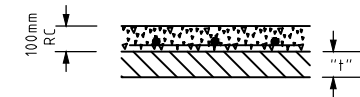

BASE COURSE THICKNESS "t" SHOULD BE DETERMINED FROM SOIL TEST ANALYSIS

OPTION A

125mm CONCRETE WITH F72 MESH ON CLASS 2A CRUSHED ROCK BASE COURSE

PAVEMENT DESIGN

PAVEMENT DESIGN SHOULD BE IN ACCORDANCE WITH VICROADS CODE OF PRACTICE RC 500.22 - SELECTION AND DESIGN OF PAVEMENTS AND SURFACINGS AND AUSTRROADS GUIDE TO PAVEMENT TECHNOLOGY PART 2 - PAVEMENT STRUCTURAL DESIGN.

RESIDENTIAL DRIVEWAY ACCESS LAYOUT GUIDELINES

GENERAL NOTES:

1. PAVEMENT COMPOSITION

THE DIAGRAMS ARE A GUIDE FOR A TYPICAL LAYOUT OF A DRIVEWAY ACCESS FOR A RURAL PROPERTY. THIS GUIDE WAS DEVELOPED IN THE INTEREST OF ROAD SAFETY AND TO PROTECT THE ROAD PAVEMENT AT THE ACCESS LOCATION. FINAL PAVEMENT COMPOSITION SHOULD BE DETERMINED BY EXISTING PAVEMENT AND SOIL TESTS AND APPROVED BY VICROADS REGIONAL OFFICE.

2. A SEALED BELLMOUTH AREA SHALL EXTEND A MINIMUM OF 6.0m FROM THE EDGE OF THE TRAFFIC LANE AS SHOWN BY THE HATCHED AREA.

3. A PLANNING PERMIT IS REQUIRED FOR A NEW ACCESS OR ALTERATION TO AN EXISTING DRIVEWAY AND MAY BE REQUIRED FOR THE REMOVAL OF NATIVE VEGETATION.

4. THE DRIVEWAY ACCESS CONSTRUCTION AND MAINTENANCE IS THE RESPONSIBILITY OF THE PROPERTY OWNER. MAINTENANCE ALSO INCLUDES ASSOCIATED DRAINAGE WORKS.

SIGHT DISTANCE

THE TRUCK DRIVER WHEN LOCATED 3m FROM THE EDGE OF THE TRAFFIC LANE NEEDS TO BE ABLE TO SEE A VEHICLE APPROACHING IN EITHER DIRECTION WHEN EXITING FROM A DRIVEWAY. REFER TO TABLE 1 FOR APPROPRIATE SIGHT DISTANCES. TREE CANOPIES, BUSHES OR OTHER OBJECTS SHALL BE REMOVED TO PROVIDE GOOD VISIBILITY AND TO PREVENT TRUCK DAMAGE. ANY TREE CANOPIES OVERHANGING THE PATH OF A TRUCK SHALL BE A MINIMUM OF 5m ABOVE THE GROUND SURFACE.

GENERAL NOTES

1. ALL DIMENSIONS ARE IN METERS
2. STANDARD WINGWALL END UNITS MAY BE ADOPTED WITH FRA APPROVAL

STANDARD DRAWINGS

TYPICAL RURAL DRIVEWAY ACCESS TO RESIDENTIAL PROPERTIES -TYPE C



ISSUE	APP'D	DATE	AMENDMENT	BY	SCALE	DATE	DESIGN BY	DRAWN BY	APPROVED	DRAWING No.	SHEET No.	ISSUE
E						05 April 17		CWS		R 601 - 10	01	

150  
100  
50  
40  
30  
20  
10

A3 ORIGINAL SIZE

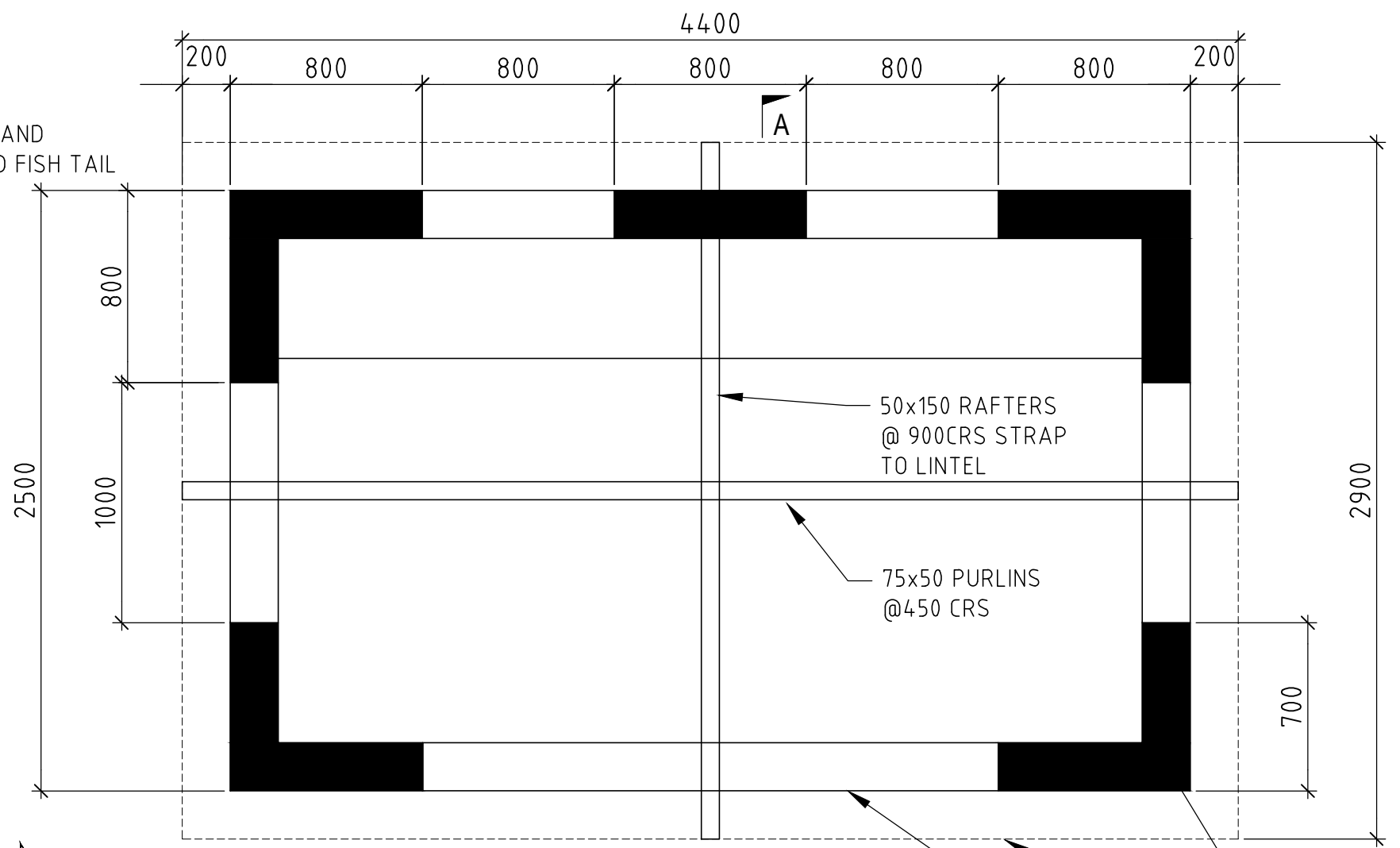
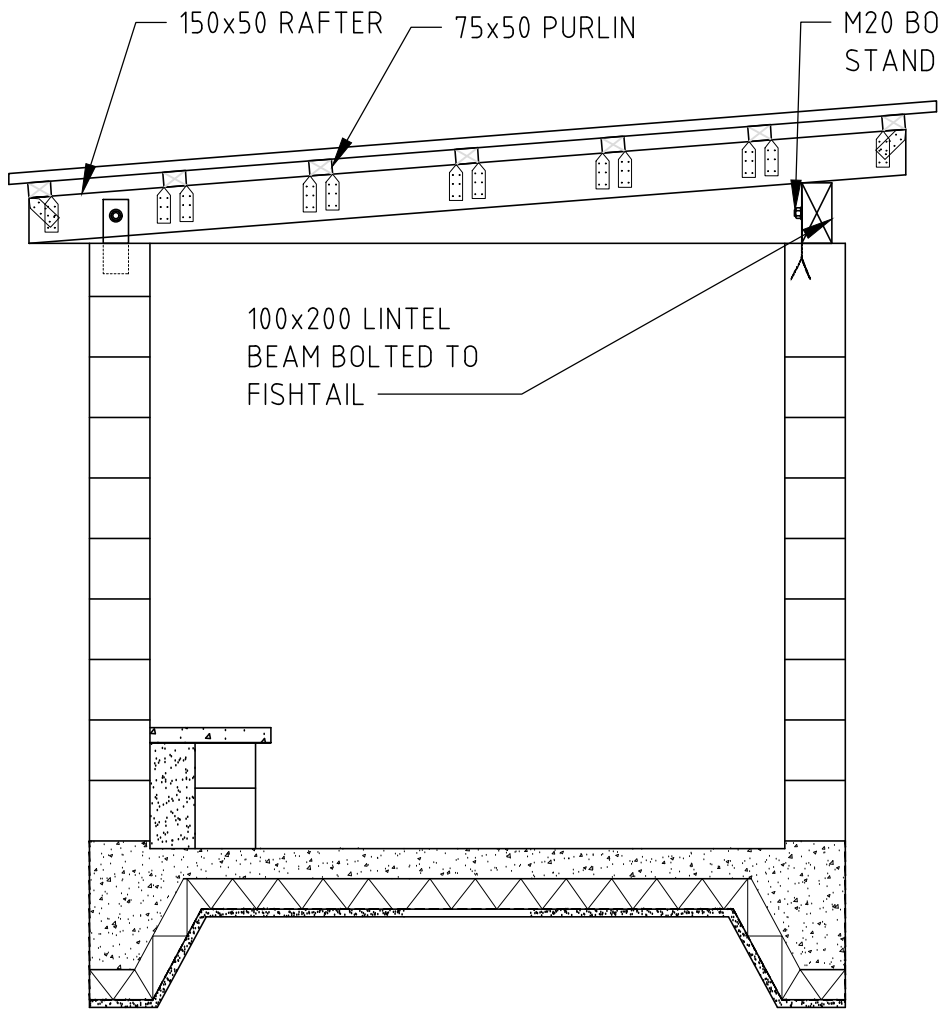

SECTION PLAN OF BUS SHELTER  
SCALE 1: 25

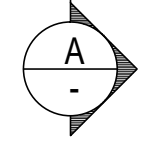

200mm BLOCK WALL WITH D16 BOLTS ON ALL FOUR CORNERS  
ROOFING OUTLINE  
100x200 LINTEL STRAPPED TO BEAM

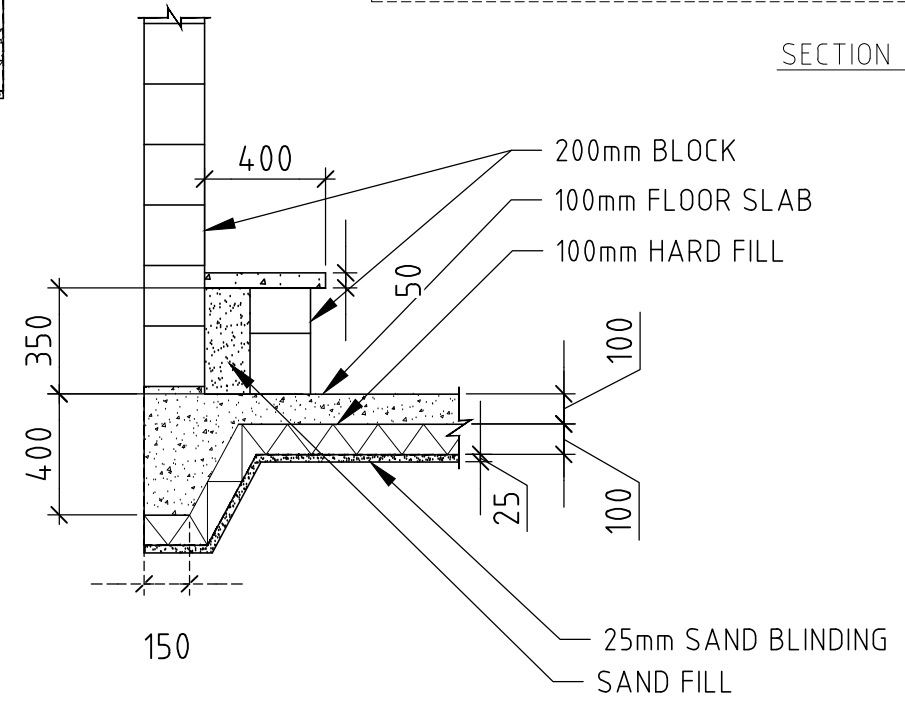

BENCH AND FOUNDATION DETAIL  
SCALE 1: 25

ISSUE	APP'D	DATE	AMENDMENT	BY
E				
D				
C				
B				
A				

GENERAL NOTES  
1. FOR TYPICAL DESIGNS OF URBAN BUS SHELTERS, REFER TO FRA

<b>STANDARD DRAWINGS</b>				
<b>STANDARD RURAL BUS SHELTER</b>				
SCALE	DATE	DESIGN BY	DRAWN BY	APPROVED
	01 MAY 17	DNR	CWS	A KETENILAGI

**Fiji Roads Authority**

DRAWING No. R 601 - 11  
SHEET No. 01  
ISSUE A

PLOT DATE 19/10/2018

150

100

50

40

30

20

10

A3 ORIGINAL SIZE

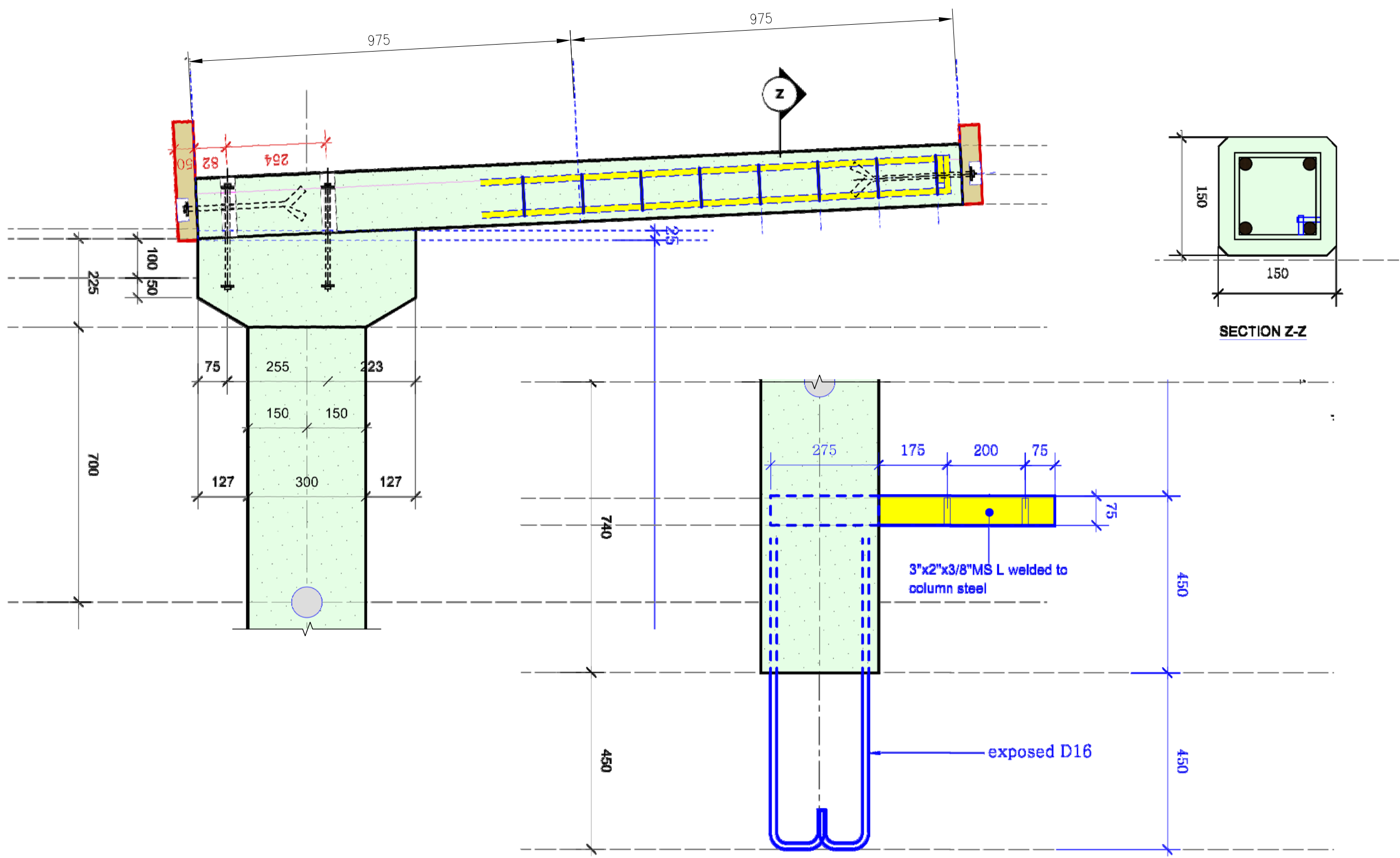

**BUS SHELTER & RAFTER & DETAIL**  
scale 1:10

ISSUE	APPD	DATE	AMENDMENT	BY
E				
D				
C				
B				
A				

GENERAL NOTES

STANDARD DRAWINGS  
TYPICAL BUS SHELTER STANDARD  
TYPE 2 : HUMES DESIGN

SCALE	DATE	DESIGN BY
	30 MAR 17	HUMES

Fiji Roads Authority

DRAWN BY	APPROVED	DRAWING No.	SHEET No.	ISSUE
CWS	A KETENILAGI	R 601 - 12	01	A

# INDEX SHEET

## SERIES 602      PAVEMENT TRENCH REINSTATEMENT DETAIL

DRAWING NUMBER	DRAWING TITLE
R 602 - 1	ROAD PAVEMENT TRENCH REINSTATEMENT METHOD

---

# M1,M2 AND ARTERIAL ROAD PAVEMENT TRENCH REINSTATEMENT METHOD

## TYPICAL BACK FILL FOR TRENCHING WORKS FOR ASPHALT AND FOAMED BITUMEN STABILIZED PAVEMENTS

PLOT DATE 19/10/2018

A3 ORIGINAL SIZE

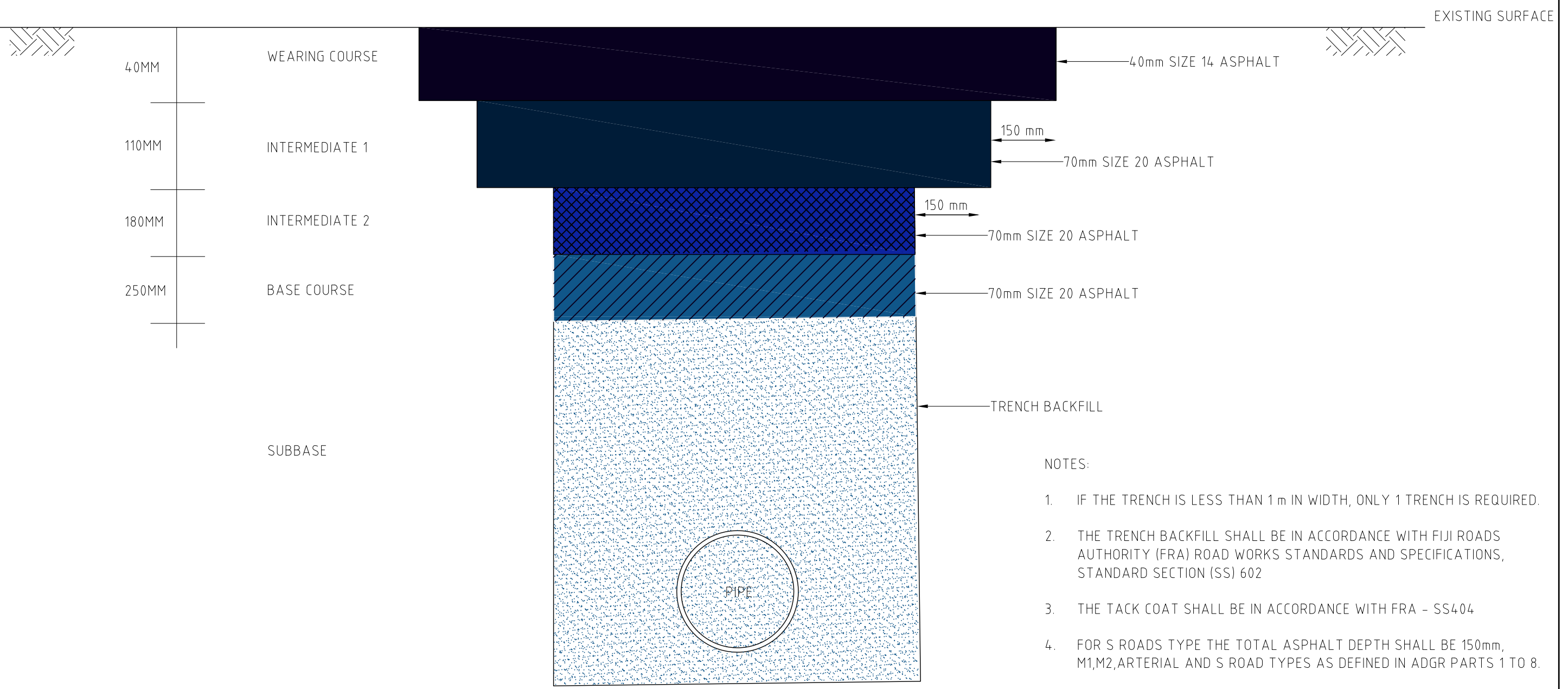

**NOTES:**

1. IF THE TRENCH IS LESS THAN 1 m IN WIDTH, ONLY 1 TRENCH IS REQUIRED.
2. THE TRENCH BACKFILL SHALL BE IN ACCORDANCE WITH FIJI ROADS AUTHORITY (FRA) ROAD WORKS STANDARDS AND SPECIFICATIONS, STANDARD SECTION (SS) 602
3. THE TACK COAT SHALL BE IN ACCORDANCE WITH FRA - SS404
4. FOR S ROADS TYPE THE TOTAL ASPHALT DEPTH SHALL BE 150mm, M1,M2,ARTERIAL AND S ROAD TYPES AS DEFINED IN ADGR PARTS 1 TO 8.

ISSUE	APPD	DATE	AMENDMENT	BY
E				
D				
C				
B				
A				

GENERAL NOTES

<b>STANDARD DRAWINGS</b>			
<b>TYPICAL ARTERIAL ROAD PAVEMENT TRENCH REINSTATEMENT DETAIL - M1, M2.</b>			
SCALE	DATE	DESIGN BY	DRAWN BY
	30 MAR 17	FRA	CWS

**Fiji Roads Authority**

APPROVED	DRAWING No.	SHEET No.	ISSUE
A KETENILAGI	R 602 - 1	01	A

# INDEX SHEET

## SERIES 603 & 604      KERBS

DRAWING NUMBER	DRAWING TITLE
R 603 - 1	CAST IN PLACE KERB SECTIONS
R 603 - 2	CAST IN PLACE SEMI MOUNTABLE KERBS
R 603 - 3	CAST IN PLACE CHANNEL PROFILE
R 604 - 1	TYPICAL PRECAST KERB AND CHANNEL DETAILS
R 604 - 2	TYPICAL NIB KERB, DISH CHANNEL & CENTRAL MEDIAN DETAIL
R 604 - 3	TYPICAL CHANNEL REPLACEMENT & FBM LEVEL DETAIL
R 604 - 4	PEDESTRIAN REFUGE ISLAND WITH KERB EXTENSION
R 604 - 5	PEDESTRIAN REFUGE ISLAND WITH ROAD WIDENING
R 604 - 6	ISLAND DETAIL
R 604 - 7	TYPICAL CAST IN-SITU KERB & CHANNEL DETAILS
R 604 - 8	TYPICAL CAST IN-SITU KERB & CHANNEL DETAILS

---

PLOT DATE 19/10/2018

150  
100  
50  
40  
30  
20  
10

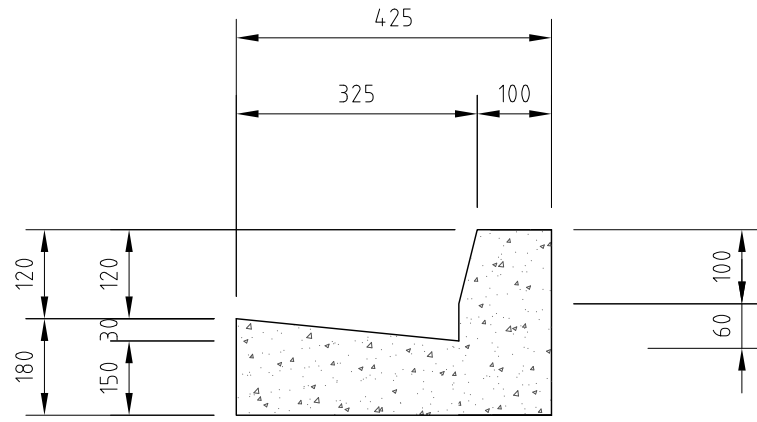

KERB & CHANNEL DETAILS

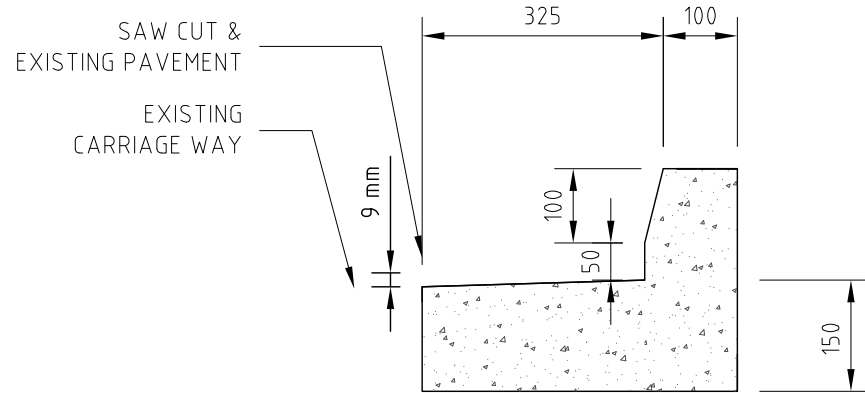

NON - MOUNTABLE KERB DETAIL

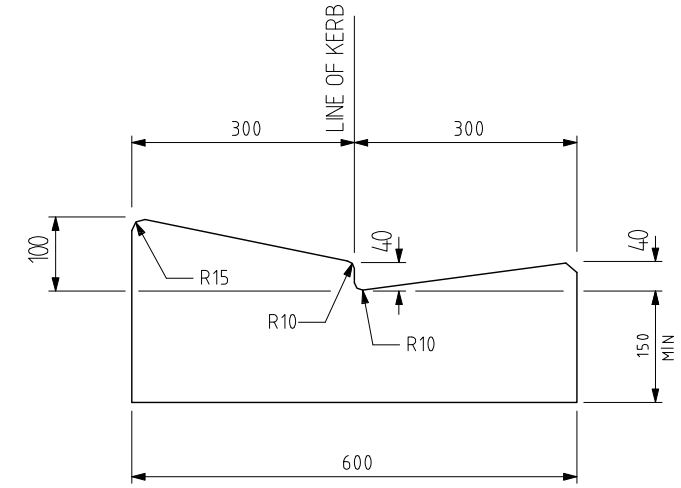

M5

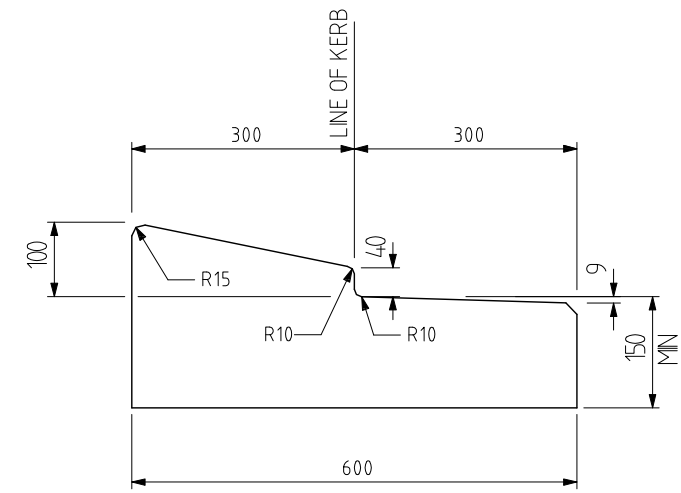

FULLY MOUNTABLE KERBS

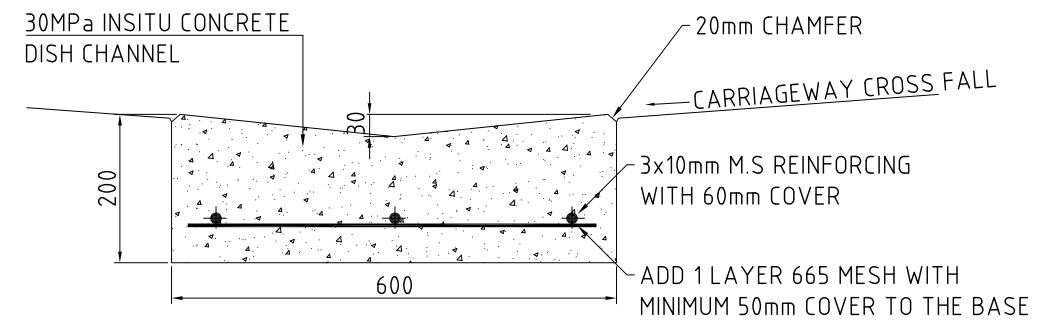

CAST IN-SITU DISH CHANNEL  
SCALE 1:5

E				
D				
C				
B				
A				
ISSUE	APPD	DATE	AMENDMENT	BY

GENERAL NOTES

STANDARD DRAWINGS			
CAST IN PLACE KERB SECTIONS			
SCALE	DATE	DESIGN BY	DRAWN BY
	05 April 17		CWS

 **Fiji Roads Authority**

APPROVED	DRAWING No.	SHEET No.	ISSUE
	R 603 - 1	01	

PLOT DATE 19/10/2018

150  
100  
50  
40  
30  
20  
10

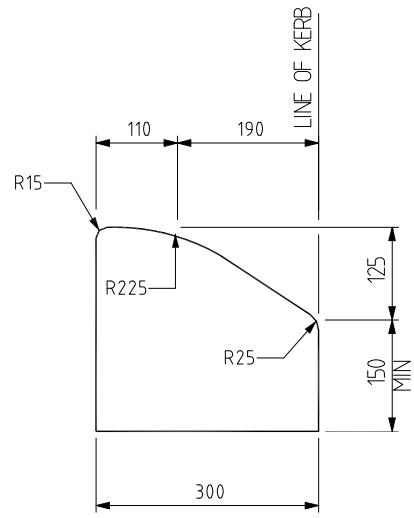

SM1

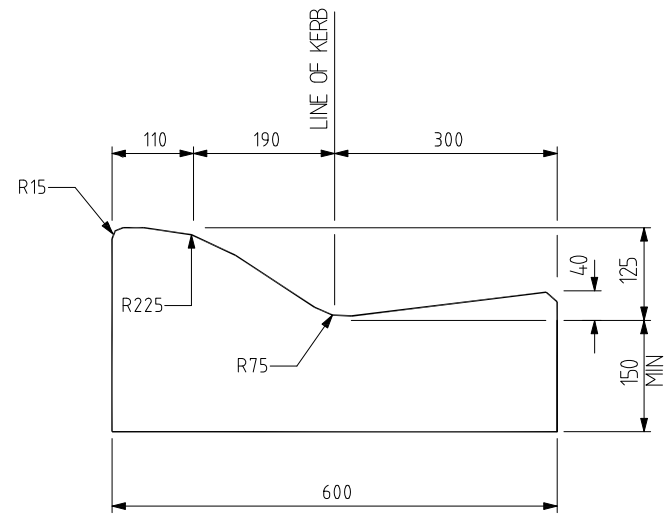

SM2

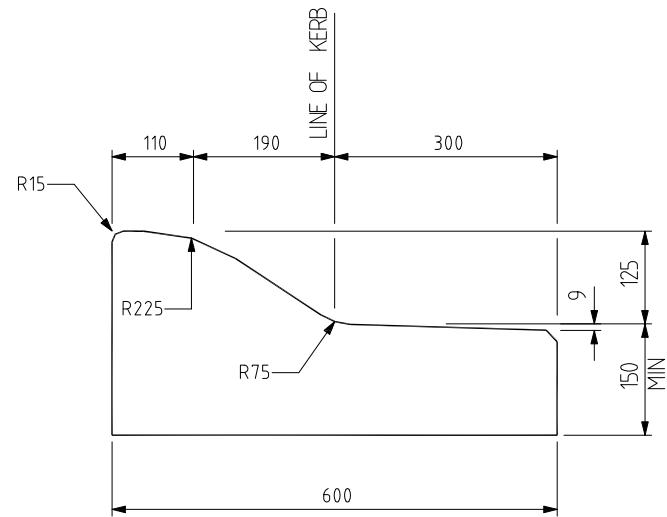

SM3  
SEMI-MOUNTABLE KERBS

A3 ORIGINAL SIZE	E			
	D			
	C			
	B			
	A			
ISSUE	APPD	DATE	AMENDMENT	BY

GENERAL NOTES

STANDARD DRAWINGS	
CAST IN PLACE SEMI MOUNTABLE KERBS	
SCALE	DATE
	05 April 17
DESIGN BY	

Fiji Roads Authority

DRAWN BY	APPROVED	DRAWING No.	SHEET No.	ISSUE
CWS		R 603 - 2	01	

PLOT DATE 19/10/2018

150

100

50

40

30

20

10

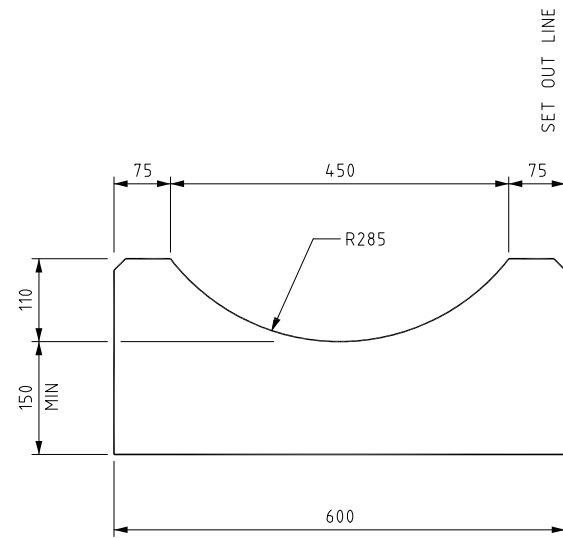

CD2 CHANNEL

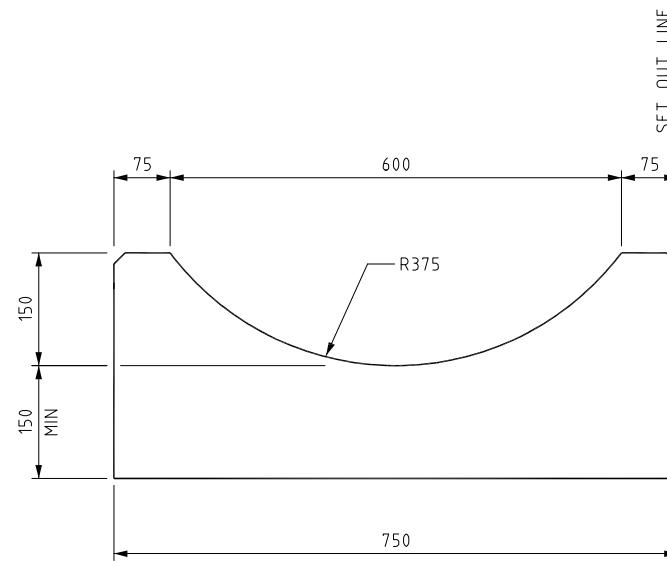

CD3 CHANNEL

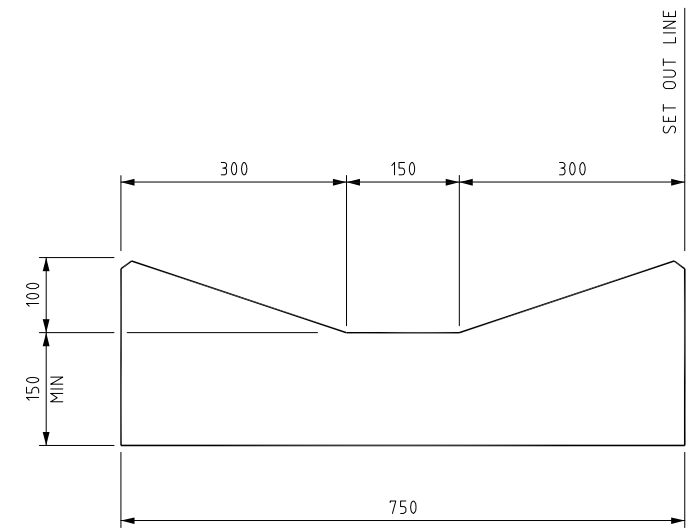

CD4 CHANNEL

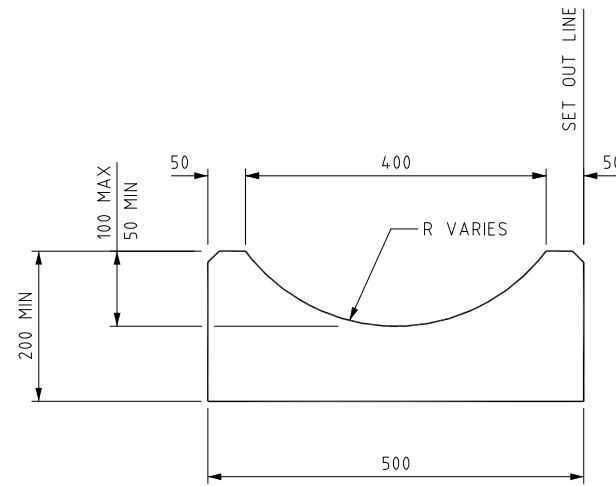

SPOON DRAIN

REFERENCES AND NOTES:

1. ALL DIMENSIONS ARE IN MILLIMETRES
2. CHAMFERS ARE 15x15 UNLESS SHOWN OTHERWISE
3. CONCRETE SHALL BE NORMAL-CLASS N25 STANDARD STRENGTH GRADE COMPLYING WITH THE REQUIREMENTS OF AS 1379
4. TRANSITIONS BETWEEN KERB TYPES SHOULD BE DEVELOPED OVER ONE METRE (MIN)
5. REFER TO AGRD PART 3 SECTION 4.6.4 AND VRS SECTION 4.6.4 FOR THE RECOMMENDED USE OF KERBS AND CHANNELS
6. CD CHANNELS SHALL NOT BE USED ADJACENT TO THE EDGE OF TRAFFIC LANE

- AS 1379 SPECIFICATION AND SUPPLY OF CONCRETE
- AS 2876 CONCRETE KERBS AND CHANNELS (GUTTERS) MANUALLY OR MACHINE PLACED
- AS 3600 CONCRETE STRUCTURES
- AS 3996 ACCESS COVERS AND GRATES

A3 ORIGINAL SIZE

E				
D				
C				
B				
A				
ISSUE	APPD	DATE	AMENDMENT	BY

GENERAL NOTES

STANDARD DRAWINGS		
CAST IN PLACE CHANNEL PROFILE		
SCALE	DATE	DESIGN BY
	05 April 17	

**Fiji Roads Authority**

DRAWN BY	APPROVED	DRAWING No.	SHEET No.	ISSUE
CWS		R 603 - 3	01	

PLOT DATE 15/05/2019

150

100

50

40

30

20

10

A3 ORIGINAL SIZE

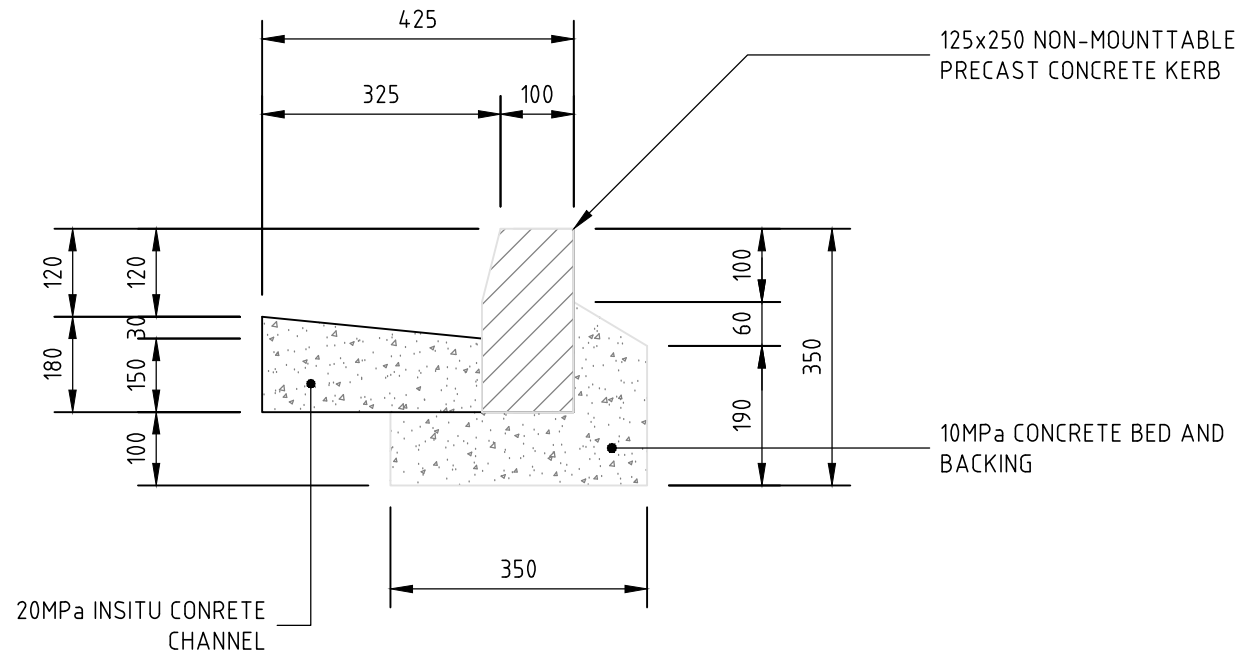

KERB & CHANNEL DETAILS

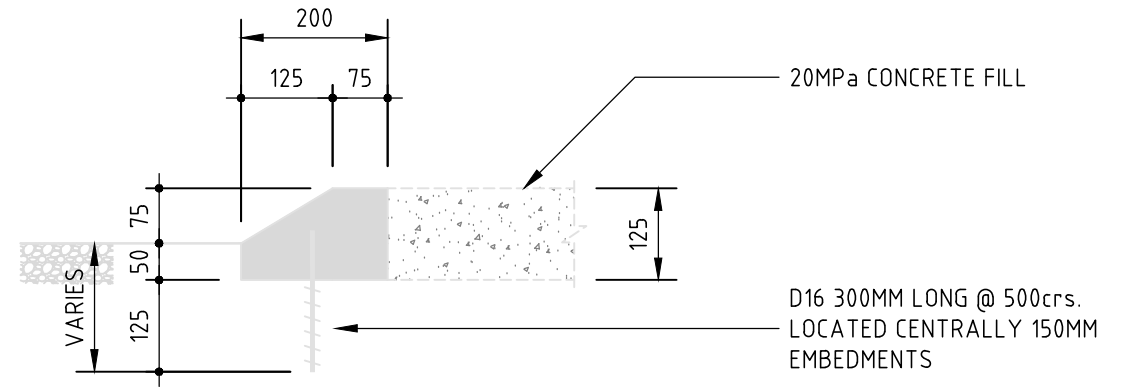

PINNED SEMI - MOUNTABLE NIB KERB

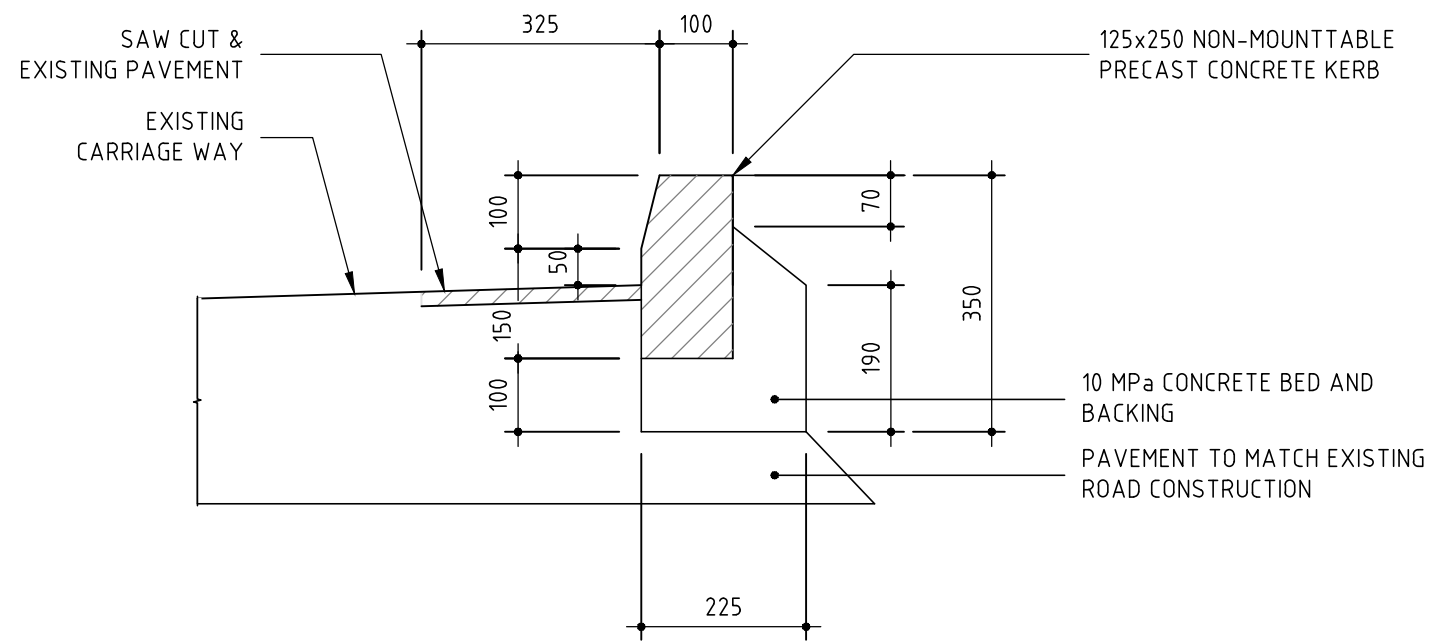

NON - MOUNTABLE KERB DETAIL

**Note:**  
The maximum gap between the precast concrete kerb unit shall be 25mm.

ISSUE	APPD	DATE	AMENDMENT	BY
E				
D				
C				
B				
A				

GENERAL NOTES

STANDARD DRAWINGS			
TYPICAL PRECAST KERB & CHANNEL DETAILS			
SCALE	DATE	DESIGN BY	DRAWN BY
	05 April 17		CWS

 **Fiji Roads Authority**

APPROVED	DRAWING No. R 604 - 1	SHEET No. 01	ISSUE
----------	-----------------------	--------------	-------

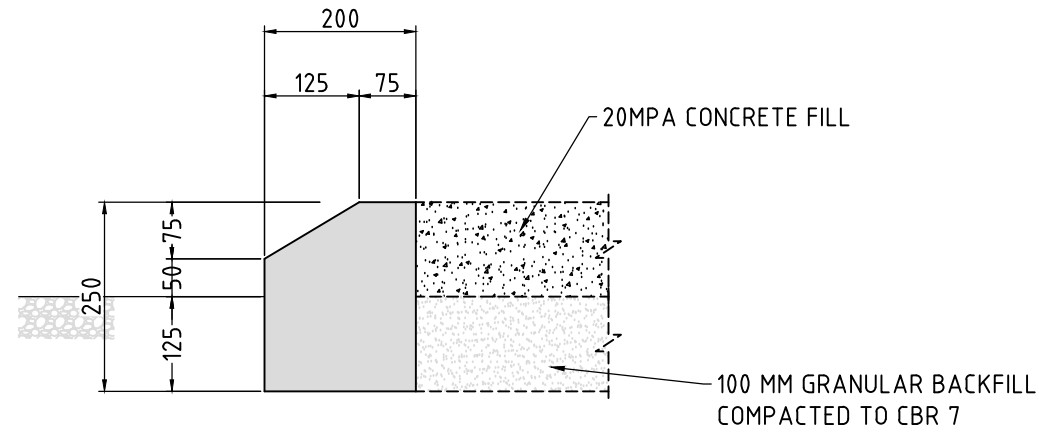

SEMI - MOUNTABLE NIB KERB  
SCALE 1:5

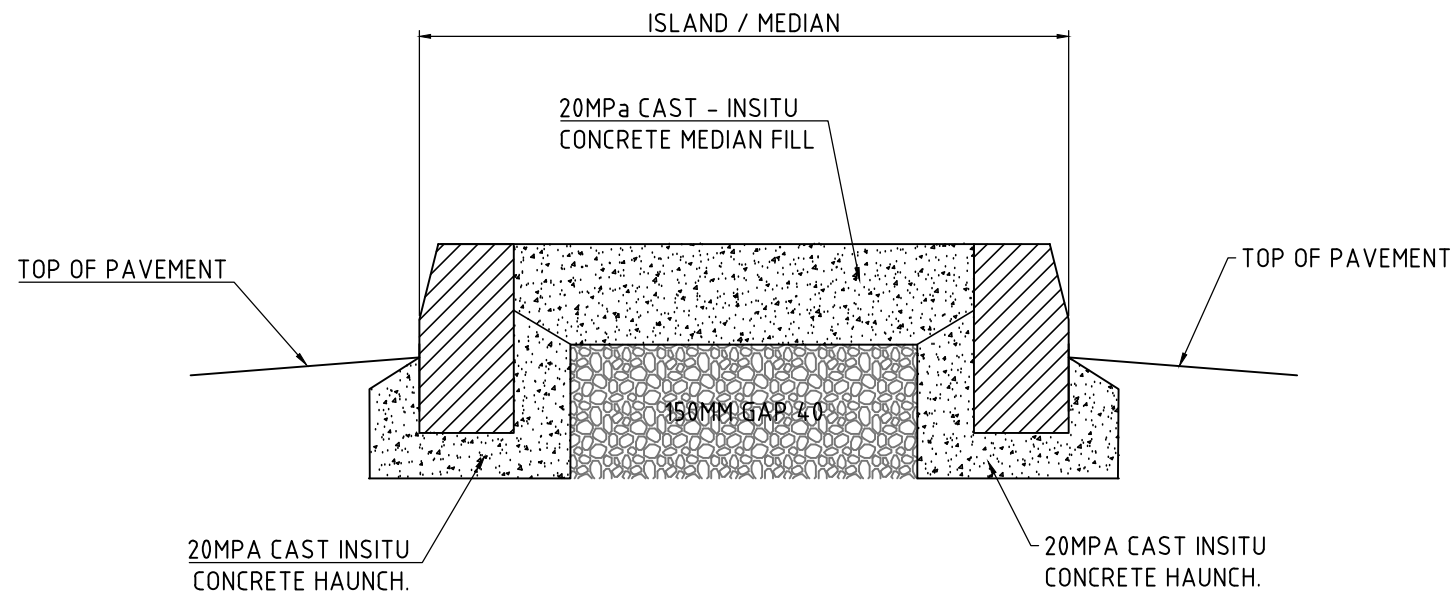

NON - CENTRAL MEDIAN  
SCALE 1:5

PLOT DATE 12/03/2019

A3 ORIGINAL SIZE

ISSUE	APP'D	DATE	AMENDMENT	BY
E				
D				
C				
B				
A				

GENERAL NOTES

1. WHERE WATER IS REQUIRED TO FLOW ACROSS THE MEDIAN, ADEQUATE GAPS OR DRAINAGE PROVISION SHALL BE MADE TO ENSURE COMPLIANCE WITH AGRD SEE 5, 5a & 5b AND FRA'S DESIGN GUIDE SUPPLEMENT

STANDARD DRAWINGS				
TYPICAL NIB KERB, DISH CHANNEL & CENTRAL MEDIAN DETAIL				
SCALE	DATE	DESIGN BY	DRAWN BY	APPROVED
	05 April 17		CWS	

DRAWING No. R 604 - 2

SHEET No. 01

ISSUE

PLOT DATE 19/10/2018

150

100

50

40

30

20

10

A3 ORIGINAL SIZE

**CHANNEL REPLACEMENT**

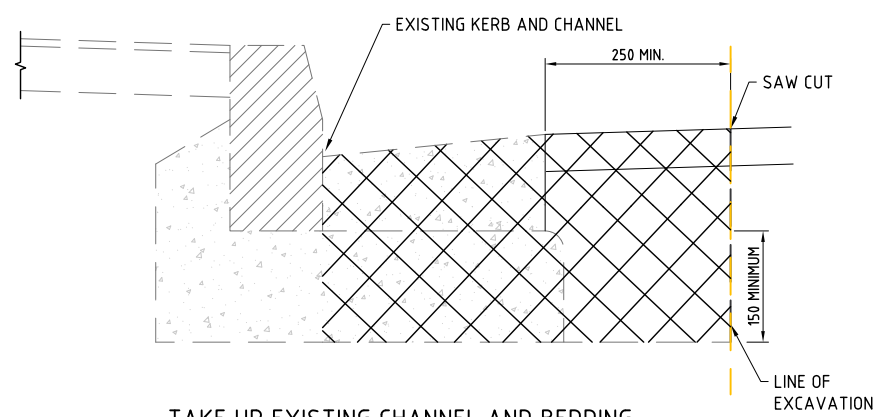

**TAKE UP EXISTING CHANNEL AND BEDDING**  
SCALE 1:5

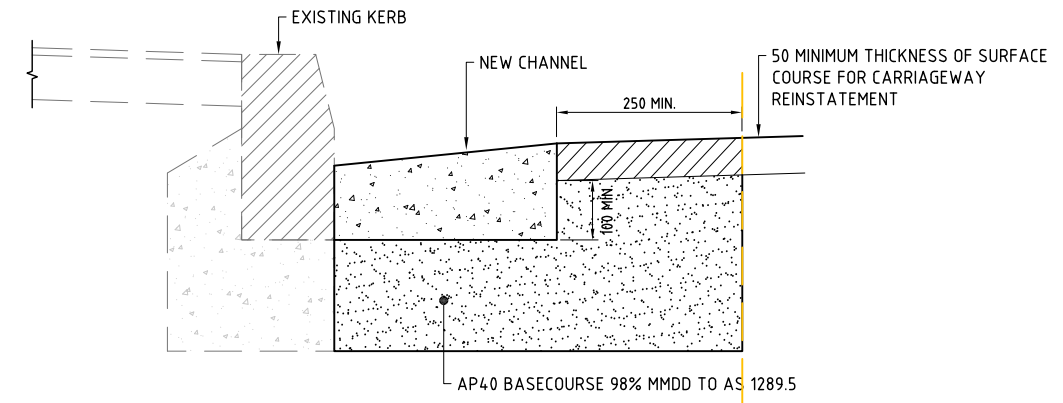

**REPLACEMENT CHANNEL LAID ON NEW BASE**  
SCALE 1:5

**FOAM BITUMEN PAVEMENT REPLACEMENT DETAIL**

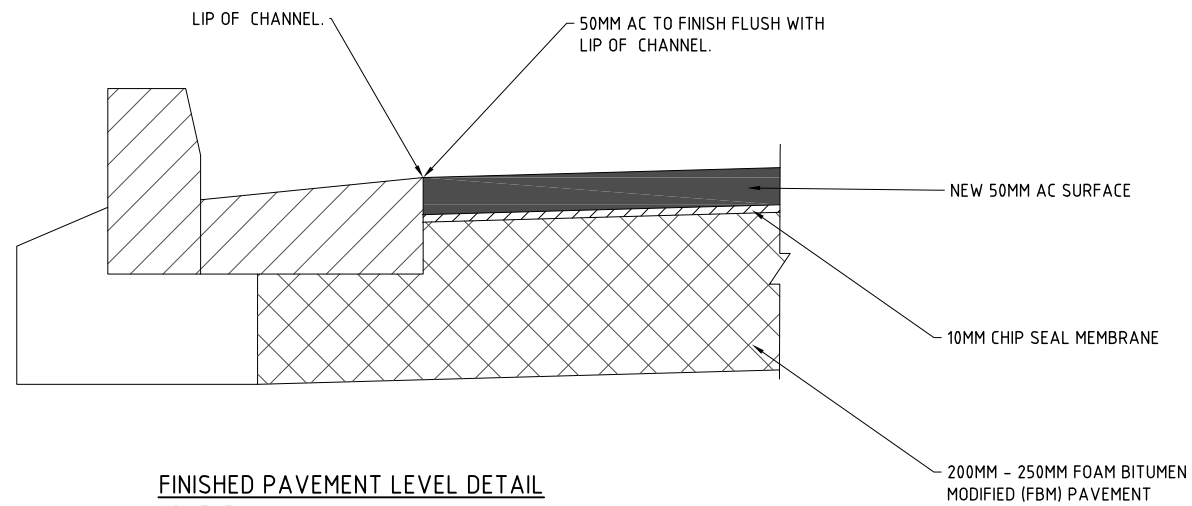

**FINISHED PAVEMENT LEVEL DETAIL**  
SCALE 1:5

E				
D				
C				
B				
A				
ISSUE	APP'D	DATE	AMENDMENT	BY

GENERAL NOTES

**STANDARD DRAWINGS**  
**TYPICAL CHANNEL REPLACEMENT & FBM LEVEL DETAIL**



SCALE	DATE	DESIGN BY	DRAWN BY	APPROVED	DRAWING No.	SHEET No.	ISSUE
	05 April 17		CWS		R 604 - 3	01	

PLOT DATE 12/03/2019

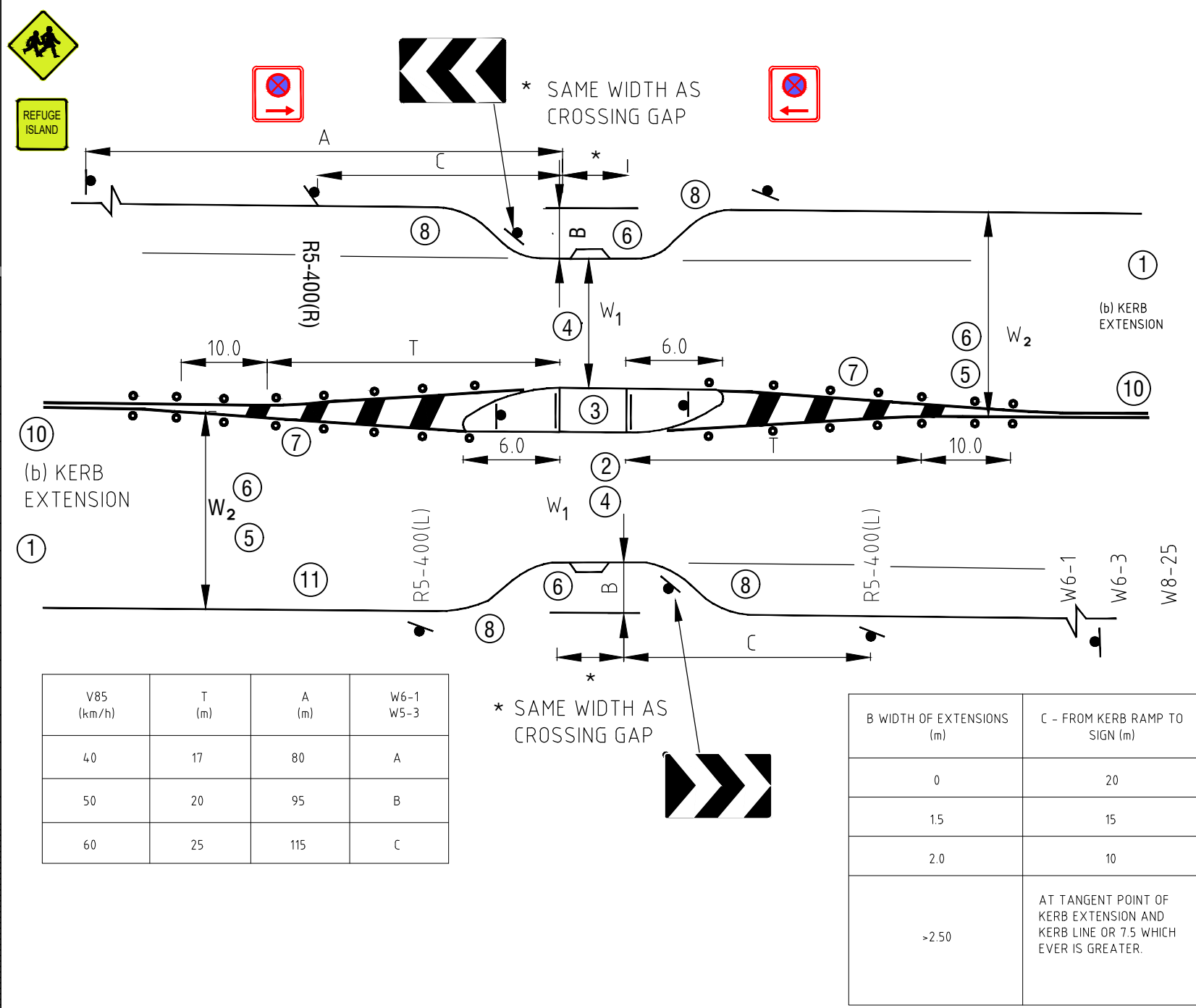

**NOTES:**

- ① THIS SKETCH SHOWS KERB EXTENSIONS AT THE REFUGE
- ② REFUGE ISLAND MINIMUM 2.0 METERS WIDE AT CROSSING, MUST HAVE BARRIER (SM) KERB. FOR REFUGE ISLAND DETAIL SEE FIGURE 5.
- ③ CROSSING GAP MINIMUM 3.0 METERS, WHERE PEDESTRIAN CROSSING USED 3.6m.
- ④ MINIMUM W1 = 3.7 meters (MAY NEED WIDENING FOR A HORIZONTAL CURVE)
- ⑤ ROAD WIDENING REQUIRED WHERE  $W2 < W1 + \frac{1}{2}$  ISLAND WIDTH
- ⑥ KERB EXTENSION REQUIRED WHERE  $W2 < W1 + \frac{1}{2}$  ISLAND WIDTH
- ⑦ INCORPORATE A SPAYED APPROACH WITH POINTED CHEVRONS ON BOTH APPROACHES TO CENTRAL ISLAND. POINTED CHEVRONS - 4.5m SPACING, 1.5m WIDTH, 45 ANGLE. RAISED PAVEMENT MARKERS AT 6.0m SPACING, FROM COMMENCEMENT OF SPLAY.
- ⑧ USE EQUAL RADII FOR KERB RETURNS,  $R = 1.707 \times B$
- ⑨ LOCATE "NO STOPPING SIGNS" SIGNS AT THE TP OF KERB EXTENSION AND THE KERBLINE, FOR KERB EXTENSIONS DESIGNED IN ACCORDANCE WITH NOTE 8
- ⑩ PAINTED MEDIAN IS PRECEDED BY A DOUBLE BARRIER (BB) LINE EXTENDING FOR 30mm MINIMUM
- ⑪ OPTIONAL LINEMARKING
- ⑫ ALL DIMENSIONS IN METERS

E				
D				
C				
B				
A				
ISSUE	APP'D	DATE	AMENDMENT	BY

**GENERAL NOTES**  
 1. FOR FURTHER DETAILS REGARDING PEDESTRIAN REFUGE DESIGN, REFER NSW TECHNICAL DIRECTION TDT 2011/01a

**STANDARD DRAWINGS**

**TYPICAL DETAILS PEDESTRIAN REFUGE ISLAND.  
TWO LANE TWO WAY WITH KERB EXTENSION.**

SCALE	DATE	DESIGN BY	DRAWN BY	APPROVED	DRAWING No.	SHEET No.	ISSUE
	05 April 17		CWS		R 604 - 4	01	



PLOT DATE 12/03/2019

150  
100  
50  
40  
30  
20  
10

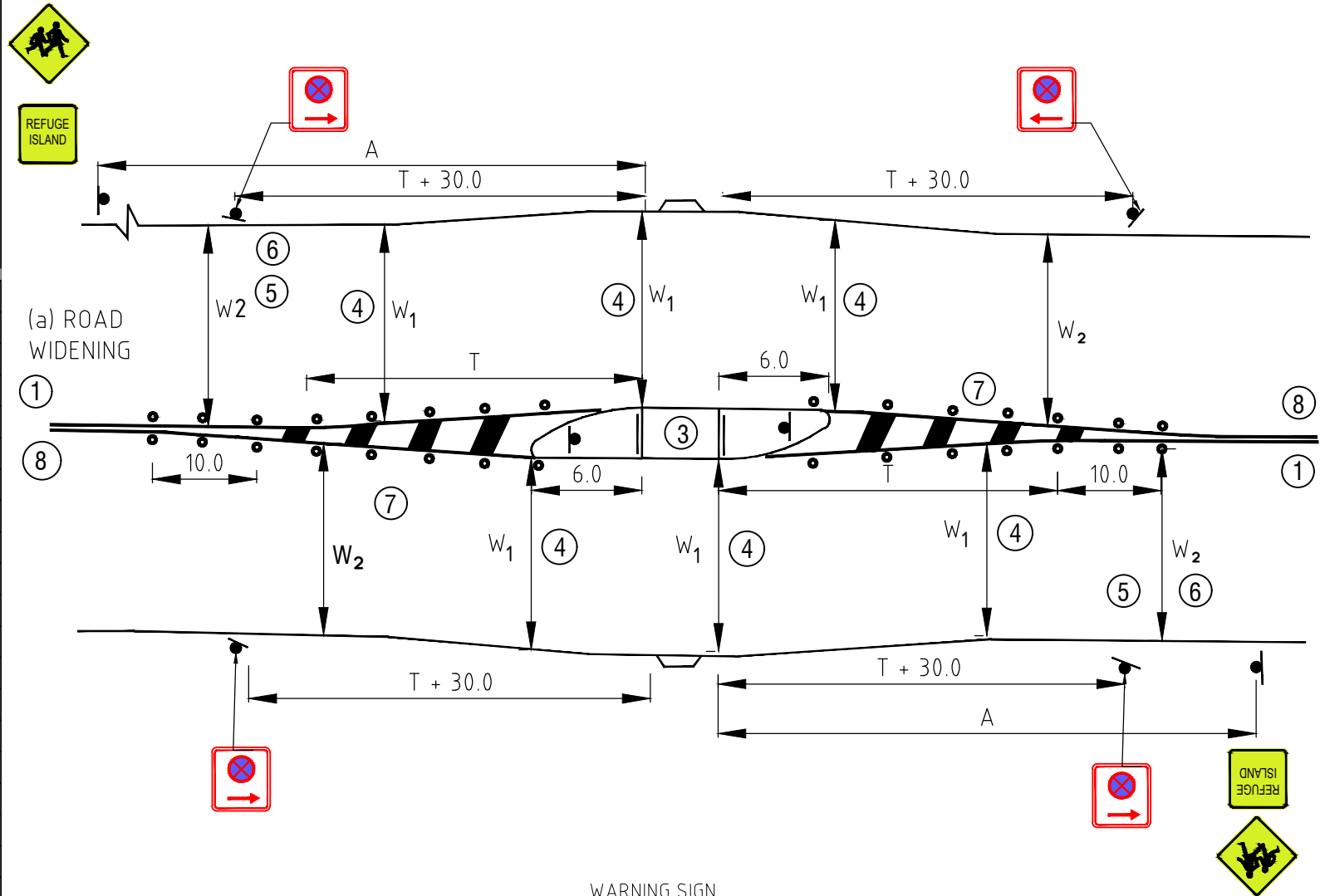

WARNING SIGN AND TAPER DETAILS

V85 (km/h)	T (m)	A (m)	W6-1 W6-3
40	17	80	A
50	20	95	B
60	25	115	C

NOTES:

- ① THIS SKETCH SHOWS KERB EXTENSIONS AT THE REFUGE
- ② REFUGE ISLAND MINIMUM 2.0 METERS WIDE AT CROSSING, MUST HAVE BARRIER (SM) KERB. FOR REFUGE ISLAND DETAIL SEE FIGURE 5.
- ③ CROSSING GAP MINIMUM 3.0 METERS, WHERE PEDESTRIAN CROSSING USED 3.6m.
- ④ MINIMUM W1 = 3.7 METERS (MAY NEED WIDENING FOR A HORIZONTAL CURVE)
- ⑤ ROAD WIDENING REQUIRED WHERE  $W2 < W1 + \frac{1}{2}$  ISLAND WIDTH
- ⑥ KERB EXTENSION REQUIRED WHERE  $W2 > W1 + \frac{1}{2}$  ISLAND WIDTH
- ⑦ INCORPORATE A SPAYED APPROACH WITH POINTED CHEVRONS ON BOTH APPROACHES TO CENTRAL ISLAND. POINTED CHEVRONS - 4.5m SPACING, 1.5m WIDTH, 45 ANGLE. RAISED PAVEMENT MARKERS AT 6.0m SPACING, FROM COMMENCEMENT OF SPLAY.
- ⑧ PAINTED MEDIAN IS PRECEDED BY A DOUBLE BARRIER (BB) LINE EXTENDING FOR 30m MINIMUM
- ⑨ ALL DIMENSIONS IN METERS

E				
D				
C				
B				
A				
ISSUE	APP'D	DATE	AMENDMENT	BY

GENERAL NOTES  
 1. FOR FURTHER DETAILS REGARDING PEDESTRIAN REFUGE DESIGN, REFER NSW TECHNICAL DIRECTION TDT 2011/01a

<b>STANDARD DRAWINGS</b>				
<b>TYPICAL DETAILS PEDESTRIAN REFUGE ISLAND. TWO LANE TWO WAY WITH ROAD WIDENING.</b>				
SCALE	DATE	DESIGN BY	DRAWN BY	APPROVED
	05 April 17		CWS	

**Fiji Roads Authority**

DRAWING No.	SHEET No.	ISSUE
R 604 - 5	01	

150  
100  
50  
40  
30  
20  
10  
A3 ORIGINAL SIZE  
PLOT DATE 12/03/2019

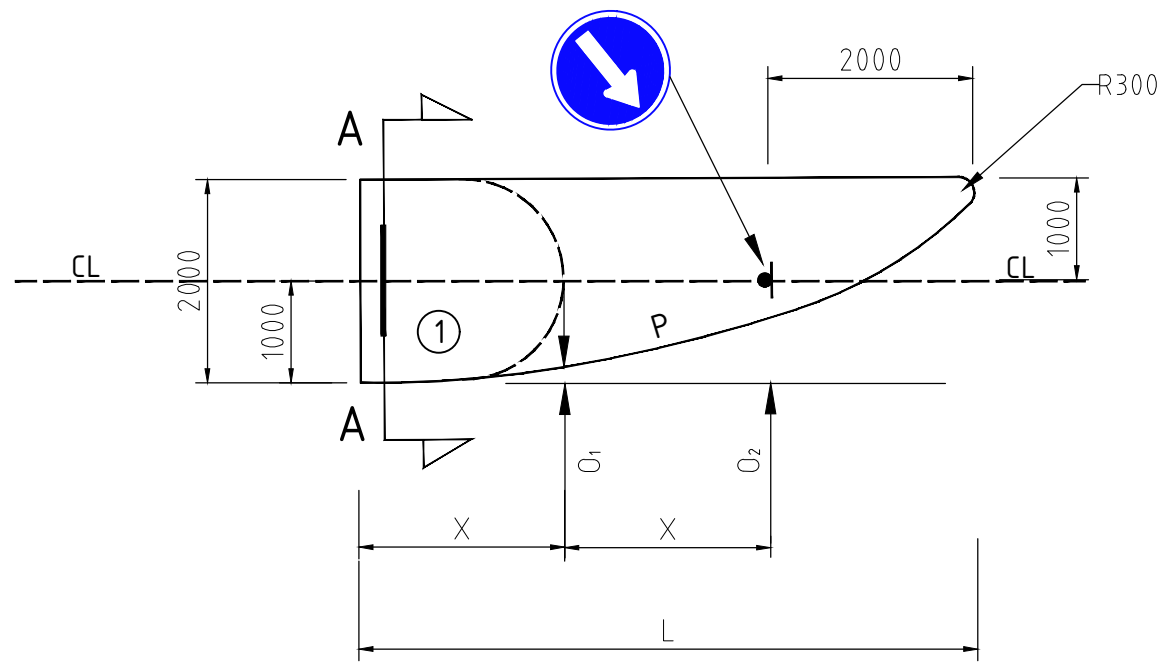

ISLAND SETOUT DETAILS

ROAD	2 LANE	4 LANE
L	6000	10000
R	13000	35000
O <sub>1</sub>	155	130
O <sub>2</sub>	630	520
X	2000	3000

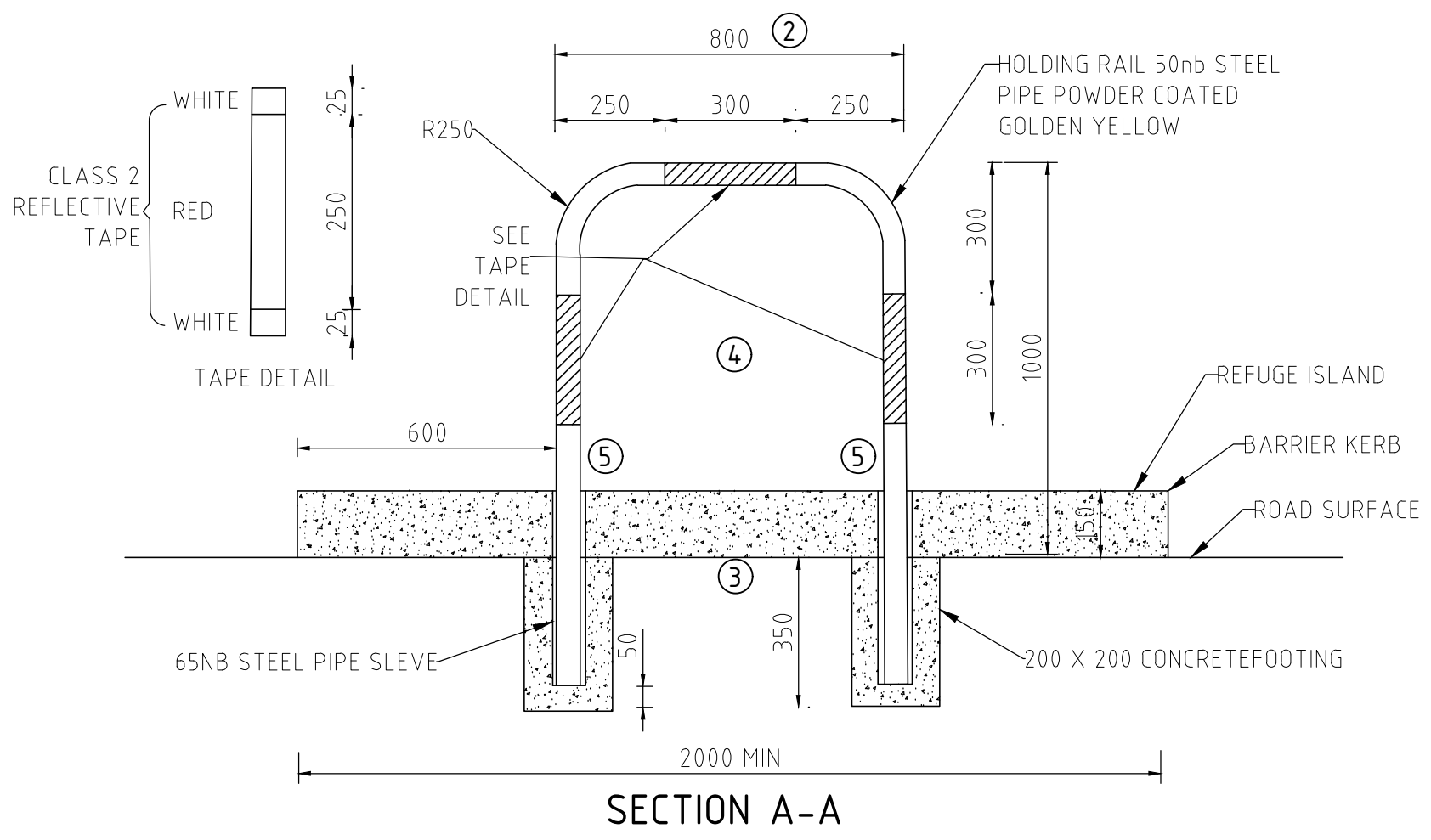

NOTES:

- ① REFUGE ISLAND AT AND NEAREST AN INTERSECTION MAY BE REDUCED TO 2m LONG.
- ② HOLDING RAIL MAY BE INCREASED UP TO A MAX. OF 1500mm LONG OR A WIDER REFUGE. CENTRALLY FIX REFLECTIVE TAPE BAND ON TOP OF ALL HOLDING RAIL. FOR RAIL WIDTHS  $\geq 1050$  LONG USE TWO 250mm WIDE RED TAPE BANDS.
- ③ IF REFUGE ISLAND GAP IS CONCRETED, IT MUST BE BRUSH FINISHED ACROSS THE DIRECTION PEDESTRIAN TRAFFIC.
- ④ DO NOT USE INFILL WITHIN THE HOLDING RAIL OPENING.
- ⑤ ALL DIMENSIONS IN MILLIMETERS

ISSUE	APP'D	DATE	AMENDMENT	BY
E				
D				
C				
B				
A				

GENERAL NOTES  
 1. FOR FURTHER DETAILS REGARDING PEDESTRIAN REFUGE DESIGN, REFER NSW TECHNICAL DIRECTION TDT 2011/01a

STANDARD DRAWINGS				
ISLAND DETAIL				
SCALE	DATE	DESIGN BY	DRAWN BY	APPROVED
	05 April 17		CWS	

**Fiji Roads Authority**

DRAWING No.	SHEET No.	ISSUE
R 604 - 6	01	

PLOT DATE 08/10/2019

TYPE	TYPICAL USE	VOLUME m <sup>3</sup> / m	PROFILE AND DIMENSIONS
SA	BARRIER KERB AND CHANNEL ADJACENT TO FOOTPATH	0.154	
SB	DISHED CROSSING	VARIABLE MINIMUM 0.170	
SE	RAISED MEDIANS AND TRAFFIC ISLANDS	0.098	
SF	RAISED MEDIANS AND TRAFFIC ISLANDS	0.043	

**NOTE:**

- ALL EXPOSED EDGES TO BE ROUNDED TO 5mm RADIUS MAXIMUM.  
x. RECESS AT BASE OF KERB MAY BE REQUIRED FOR SUBBASE LAYER.
- THE CONCRETE LINING MUST COMPLY WITH REQUIREMENTS OF AS 1379, AND SHALL HAVE A MINIMUM COMPRESSIVE STRENGTH AT 28 DAYS OF 25 MPa.

A3 ORIGINAL SIZE	E				
	D				
	C				
	B				
	A				
ISSUE	APP'D	DATE	AMENDMENT	BY	

GENERAL NOTES

**STANDARD DRAWINGS**  
**TYPICAL CAST IN-SITU KERB & CHANNEL**  
**DETAILS**

SCALE	DATE 1 OCTOBER 19	DESIGN BY
-------	----------------------	-----------

**Fiji Roads Authority**

DRAWN BY S. FREMLIN	APPROVED M. J. DALE	DRAWING No. R 604 - 7	SHEET No. 01	ISSUE
------------------------	------------------------	--------------------------	-----------------	-------

PLOT DATE 08/10/2019

TYPE	TYPICAL USE	VOLUME m <sup>3</sup> / m	PROFILE AND DIMENSIONS
SFM	RAISED MEDIANS AND TRAFFIC ISLANDS WITH MOWING STRIP	0.092	
SK	CHANNEL ADJACENT TO SHOULDERS IN CUTTINGS	VARIABLE MINIMUM 0.276	
SM	BARRIER KERB AT TRAFFIC ISLANDS	0.043	
SO	DISHED CROSSING, INCREASED WATERWAY	VARIABLE MINIMUM 0.200	

**NOTE:**

- ALL EXPOSED EDGES TO BE ROUNDED TO 5mm RADIUS MAXIMUM.  
x. RECESS AT BASE OF KERB MAY BE REQUIRED FOR SUBBASE LAYER.
- THE CONCRETE LINING MUST COMPLY WITH REQUIREMENTS OF AS 1379, AND SHALL HAVE A MINIMUM COMPRESSIVE STRENGTH AT 28 DAYS OF 25 MPa.

A3 ORIGINAL SIZE	E				
	D				
	C				
	B				
	A				
ISSUE	APP'D	DATE	AMENDMENT	BY	

GENERAL NOTES

**STANDARD DRAWINGS**  
**TYPICAL CAST IN-SITU KERB & CHANNEL**  
**DETAILS**

SCALE: \_\_\_\_\_ DATE: 12 SEPTEMBER 19 \_\_\_\_\_ DESIGN BY: \_\_\_\_\_

**Fiji Roads Authority**

DRAWN BY S. FREMLIN	APPROVED M. J. DALE	DRAWING No. R 604 - 8	SHEET No. 01	ISSUE
------------------------	------------------------	--------------------------	-----------------	-------

## SERIES 700 ROAD FURNITURE & PAVEMENT MARKINGS

DRAWING NUMBER	DRAWING TITLE
R 701 - 1	TYPICAL HAND RAIL DETAILS – DOUBLE RAIL
R 702 - 1	TYPICAL HAND RAIL DETAILS – SINGLE RAIL
R 703 - 1	TYPICAL SIGN INSTALLATION DETAIL
R 704 - 1	TYPICAL FENCE DETAIL – NO HAND RAIL
R 705 - 1	TYPICAL PAVEMENT MARKING DETAILS
R 705 - 2	TYPICAL PAVEMENT MARKING DETAILS
R 705 - 3	TYPICAL GUIDE POST DETAILS
R 705 - 4	COASTAL REVETMENT DETAILS
R 705 - 5	TYPICAL DETAILS HUMP SIGNS & FLAT TOP HUMP DETAIL
R 705 - 6	RAISED PEDESTRIAN CROSSING

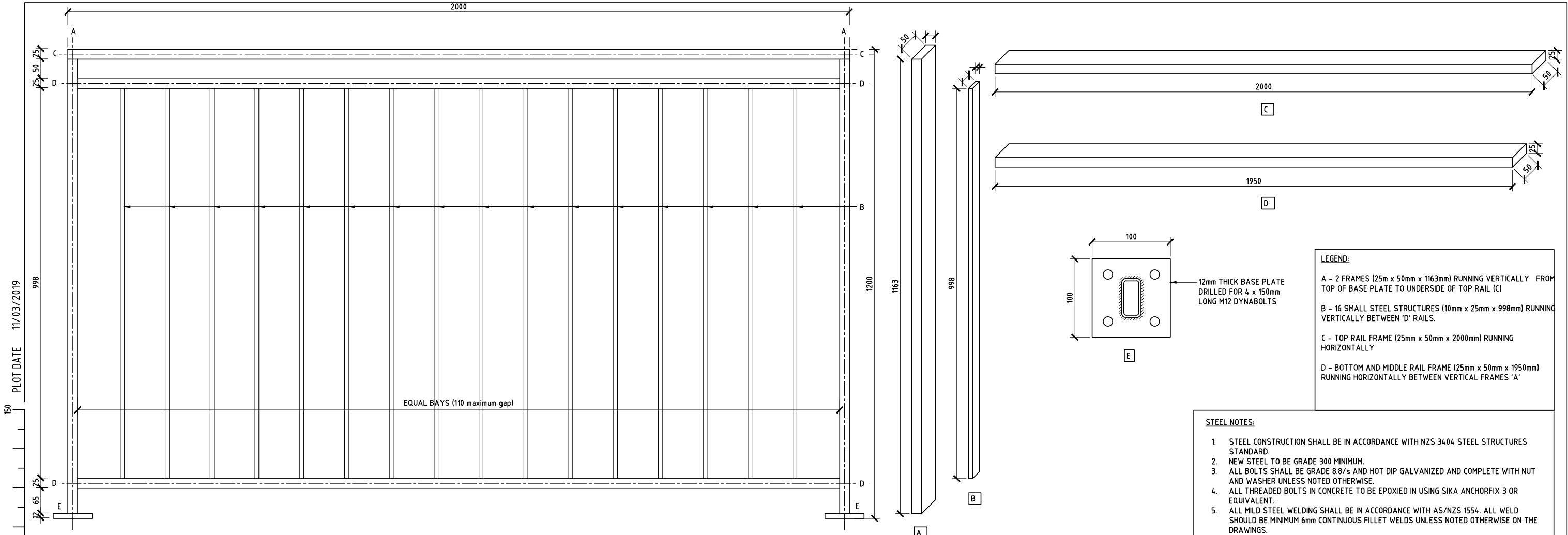

1 SINGLE FRAME ELEVATION  
SCALE 1:10

- LEGEND:**
- A - 2 FRAMES (25m x 50mm x 1163mm) RUNNING VERTICALLY FROM TOP OF BASE PLATE TO UNDERSIDE OF TOP RAIL (C)
  - B - 16 SMALL STEEL STRUCTURES (10mm x 25mm x 998mm) RUNNING VERTICALLY BETWEEN 'D' RAILS.
  - C - TOP RAIL FRAME (25mm x 50mm x 2000mm) RUNNING HORIZONTALLY
  - D - BOTTOM AND MIDDLE RAIL FRAME (25mm x 50mm x 1950mm) RUNNING HORIZONTALLY BETWEEN VERTICAL FRAMES 'A'

- STEEL NOTES:**
1. STEEL CONSTRUCTION SHALL BE IN ACCORDANCE WITH NZS 3404 STEEL STRUCTURES STANDARD.
  2. NEW STEEL TO BE GRADE 300 MINIMUM.
  3. ALL BOLTS SHALL BE GRADE 8.8/s AND HOT DIP GALVANIZED AND COMPLETE WITH NUT AND WASHER UNLESS NOTED OTHERWISE.
  4. ALL THREADED BOLTS IN CONCRETE TO BE EPOXIED IN USING SIKA ANCHORFIX 3 OR EQUIVALENT.
  5. ALL MILD STEEL WELDING SHALL BE IN ACCORDANCE WITH AS/NZS 1554. ALL WELD SHOULD BE MINIMUM 6mm CONTINUOUS FILLET WELDS UNLESS NOTED OTHERWISE ON THE DRAWINGS.
  6. ALL NEW STEEL ELEMENTS TO BE SHOP FABRICATED.
  7. ALL STEEL ELEMENTS TO BE CLEANED AND PAINTED USING RESENE AS PER SPECIFICATION UNLESS NOTED OTHERWISE.
  8. ALL POSTS AND BARS TO BE VERTICAL.
  9. ALL SPLICES TOP & BOTTOM TO BE SLEEVED.
  10. ALL BUTT WELDS TO BE FULL DEPTH AND GROUND FLUSH.
  11. VERTICAL BARS @ 125mm CRS.
  12. ALL ASSEMBLY TO BE PAINTED AS PER PAINT SPECIFICATION

- PAINT SYSTEM APPLICATION NOTES:**
- TEMPERATURE:**
1. AMBIENT/TROPICAL < 90°C DRY
- SURFACE PREPARATION:**
1. DEGREASE TO SSPC-SP1. WATERBLAST @ 3000psi/15L MINUTE MINIMUM TO CLEAN STEEL
  2. REMOVE ALL SHARP EDGES
  3. POWER TOOL CLEAN TO SSPC-SP11 (SP-3 AS A MINIMUM) & ACHIEVE A SURFACE PROFILE OF NO MORE THAN 50um. SEAL ALL CREVICES AFTER PAINTING.
- COATING SYSTEM:**
1. APPLY RESENE ARMOUR ZINC 120, A 2 PACK ZINC RICH EPOXY @ 75 MICRONS DFT
  2. RESENE ARMOURCOTE 510 CONFORMING TO A AS/NZS 2312-14 - STANDARD SOUTH PACIFIC VERSION, A 2 PACK HIGH BUILD EPOXY @ 200 MICRONS DFT.
  3. FINALLY FINISHING COAT OF RESENE URACRYL 403, A 2 PACK ACRYLIC URTHANE AT 150 MICRONS DFT

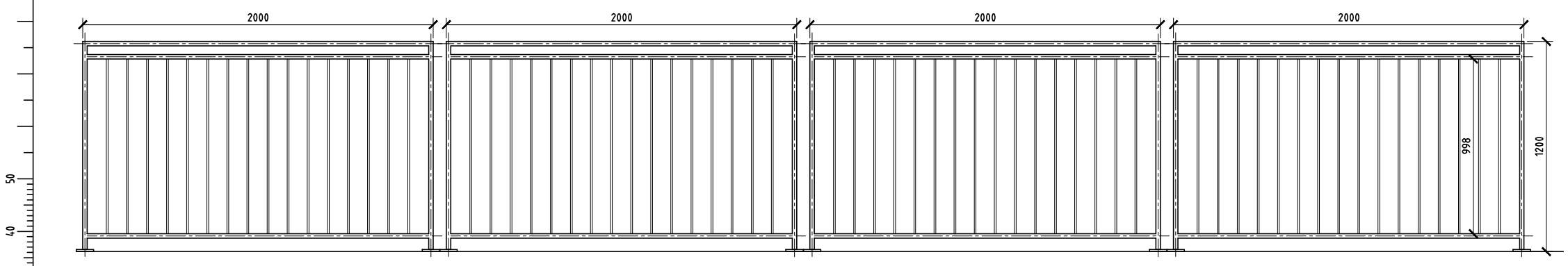

2 MULTI FRAME ELEVATION  
SCALE 1:30

A3 ORIGINAL SIZE	F				
	D				
	C				
	B				
	A				
ISSUE	APPD	DATE	AMENDMENT	BY	

GENERAL NOTES

**STANDARD DRAWINGS**

STEEL HANDRAIL DETAILS – DOUBLE RAIL

SCALE	DATE	DESIGN BY
	11 March 19	

**Fiji Roads Authority**

DRAWN BY	APPROVED	DRAWING No.	SHEET No.	ISSUE
S VOLAU		R 701 - 1	01	

PLOT DATE 11/03/2019

150

100

50

40

30

20

10

A3 ORIGINAL SIZE

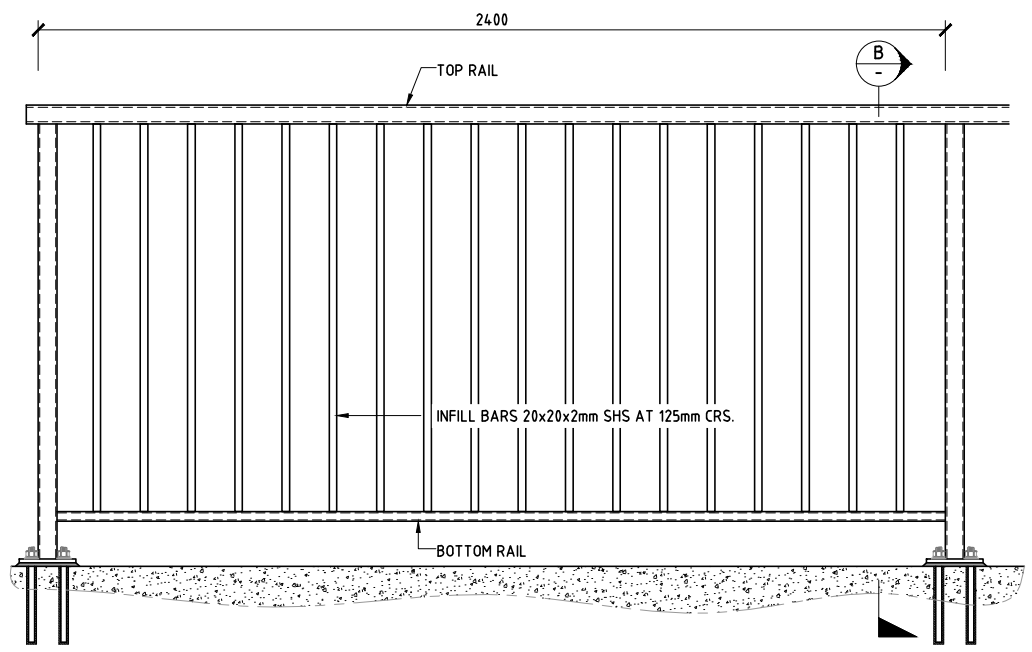

A HAND RAIL TYPICAL ELEVATION  
SCALE 1:20

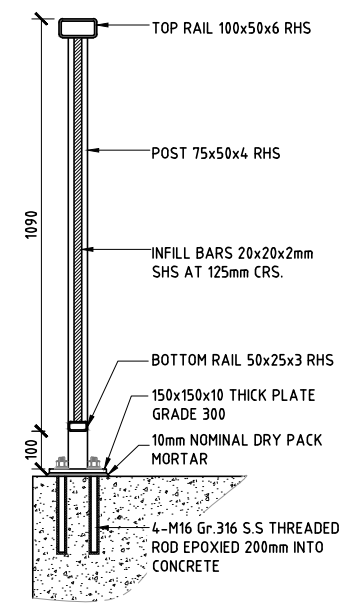

B SECTION B-B  
SCALE 1:20

- STEEL NOTES:**
1. STEEL CONSTRUCTION SHALL BE IN ACCORDANCE WITH NZS 3404 STEEL STRUCTURES STANDARD.
  2. NEW STEEL TO BE GRADE 300 MINIMUM.
  3. ALL BOLTS SHALL BE GRADE 8.8/s AND HOT DIP GALVANIZED AND COMPLETE WITH NUT AND WASHER UNLESS NOTED OTHERWISE.
  4. ALL THREADED BOLTS IN CONCRETE TO BE EPOXIED IN USING SIKA ANCHORFIX 3 OR EQUIVALENT.
  5. ALL MILD STEEL WELDING SHALL BE IN ACCORDANCE WITH AS/NZS 1554. ALL WELD SHOULD BE MINIMUM 6mm CONTINUOUS FILLET WELDS UNLESS NOTED OTHERWISE ON THE DRAWINGS.
  6. ALL NEW STEEL ELEMENTS TO BE SHOP FABRICATED.
  7. ALL STEEL ELEMENTS TO BE CLEANED AND PAINTED USING RESENE AS PER SPECIFICATION UNLESS NOTED OTHERWISE.
  8. ALL POSTS AND BARS TO BE VERTICAL.
  9. ALL SPLICES TOP & BOTTOM TO BE SLEEVED.
  10. ALL BUTT WELDS TO BE FULL DEPTH AND GROUND FLUSH.
  11. VERTICAL BARS @ 125mm CRS.
  12. ALL ASSEMBLY TO BE PAINTED AS PER PAINT SPECIFICATION
- PAINT SYSTEM APPLICATION NOTES:**
- TEMPERATURE:
1. AMBIENT/TROPICAL < 90°C DRY
- SURFACE PREPARATION:
1. DEGREASE TO SSPC-SP1. WATERBLAST @ 3000psi/15L MINUTE MINIMUM TO CLEAN STEEL
  2. REMOVE ALL SHARP EDGES
  3. POWER TOOL CLEAN TO SSPC-SP11 (SP-3 AS A MINIMUM) & ACHIEVE A SURFACE PROFILE OF NO MORE THAN 50um. SEAL ALL CREVICES AFTER PAINTING.
- COATING SYSTEM:
1. APPLY RESENE ARMOUR ZINC 120, A 2 PACK ZINC RICH EPOXY @ 75 MICRONS DFT
  2. RESENE ARMOURCOTE 510 CONFORMING TO A AS/NZS 2312-14 - STANDARD SOUTH PACIFIC VERSION, A 2 PACK HIGH BUILD EPOXY @ 200 MICRONS DFT.
  3. FINALLY FINISHING COAT OF RESENE URACRYL 403, A 2 PACK ACRYLIC URTHANE AT 150 MICRONS DFT

GENERAL NOTES

STANDARD DRAWINGS

STEEL HANDRAIL DETAILS



ISSUE	APP'D	DATE	AMENDMENT	BY
E				
D				
C				
B				
A				

SCALE	DATE	DESIGN BY	DRAWN BY	APPROVED	DRAWING No.	SHEET No.	ISSUE
	11 March 19		S VOLAU		R 702 - 1	01	

PLOT DATE 19/10/2018

150  
100  
50  
40  
30  
20  
10

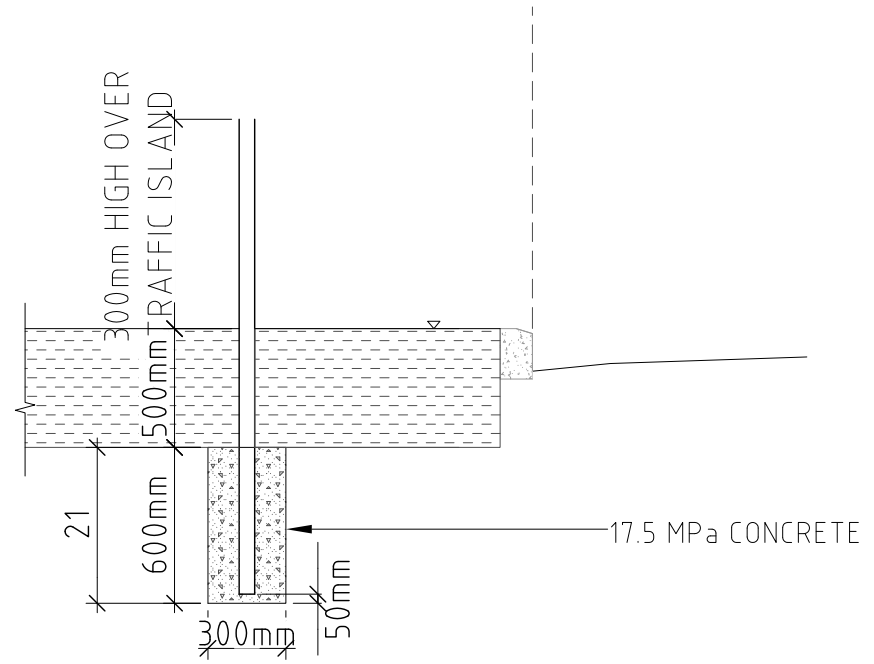

TYPICAL SIGN INSTALLATION ON PLANTED ISLAND  
SCALE : NTS

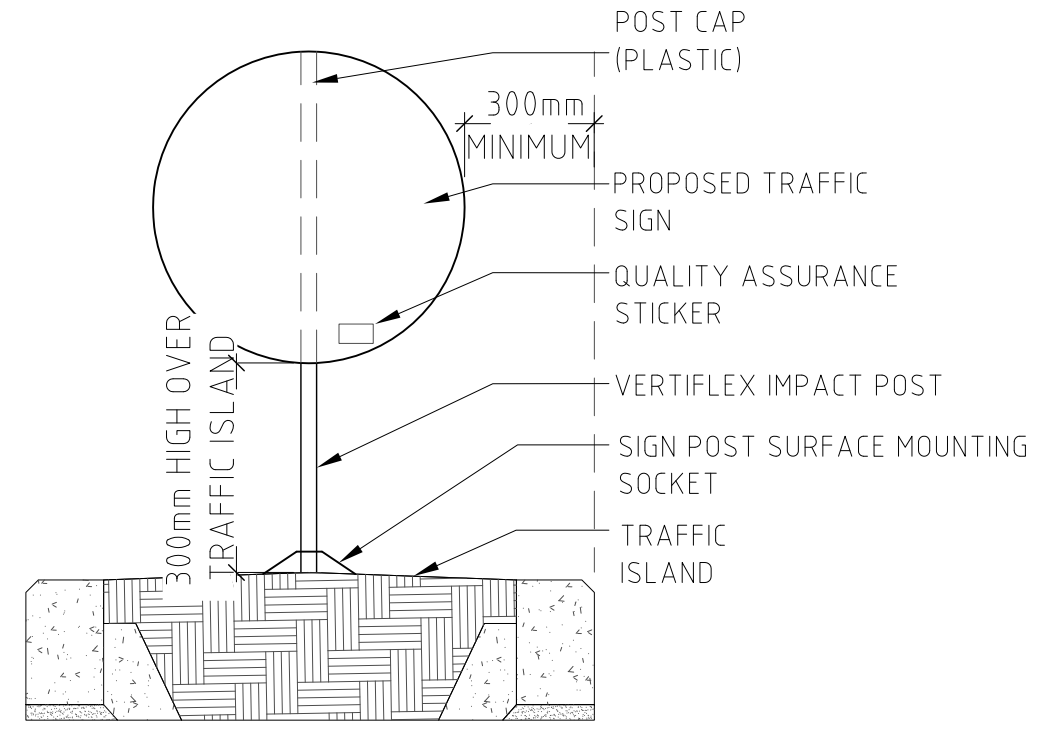

TYPICAL SIGN INSTALLATION ON TRAFFIC ISLAND  
SCALE : NTS

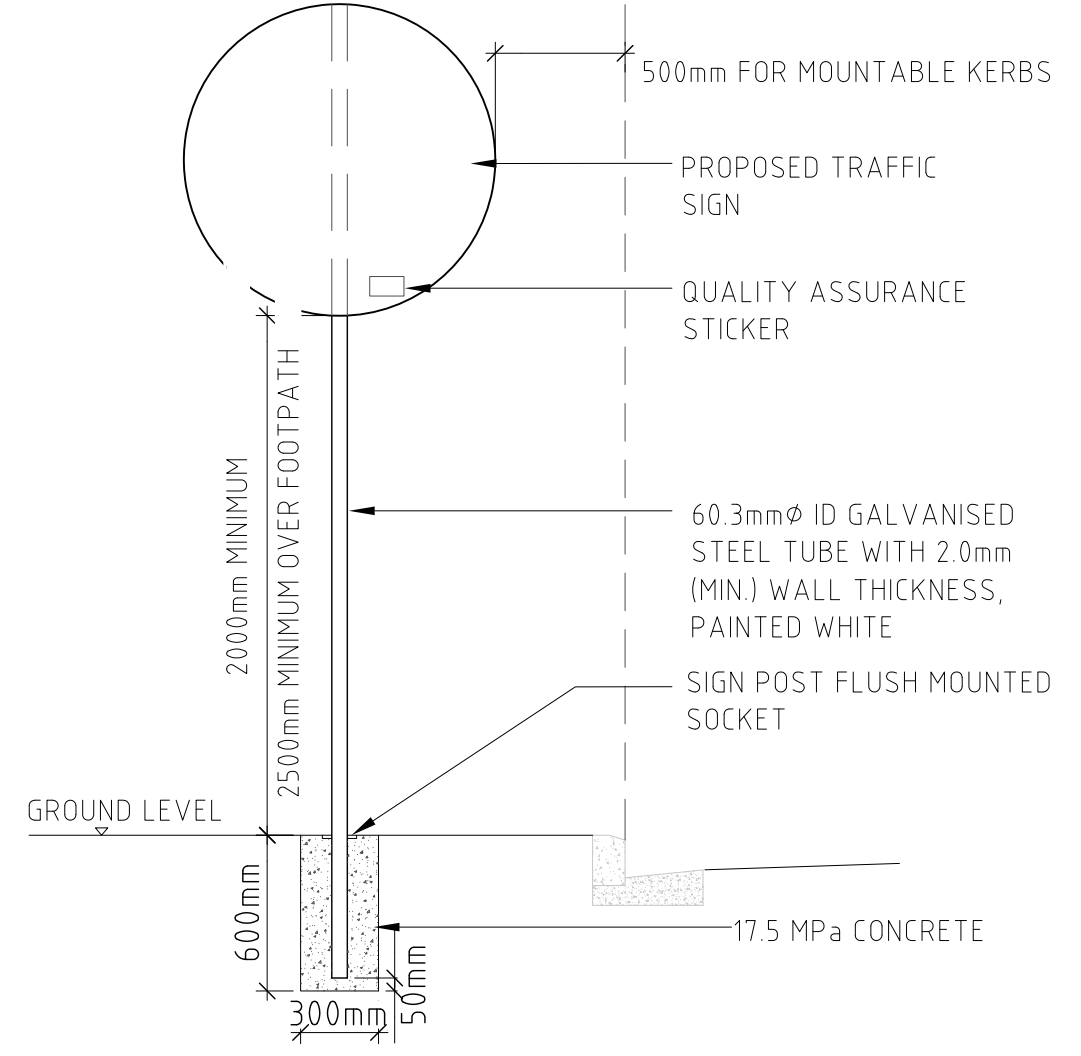

TYPICAL SIGN INSTALLATION DETAIL  
SCALE : NTS

E					
D					
C					
B					
A					
ISSUE	APPD	DATE	AMENDMENT	BY	

GENERAL NOTES

STANDARD DRAWINGS	
SIGN INSTALLATION TYPICAL DETAIL	
SCALE	DATE
	05 April 17
DESIGN BY	

 **Fiji Roads Authority**

DRAWN BY	APPROVED	DRAWING No.	SHEET No.	ISSUE
CWS		R 703 - 1	02	

PLOT DATE 11/03/2019

150

100

50

40

30

20

10

A3 ORIGINAL SIZE

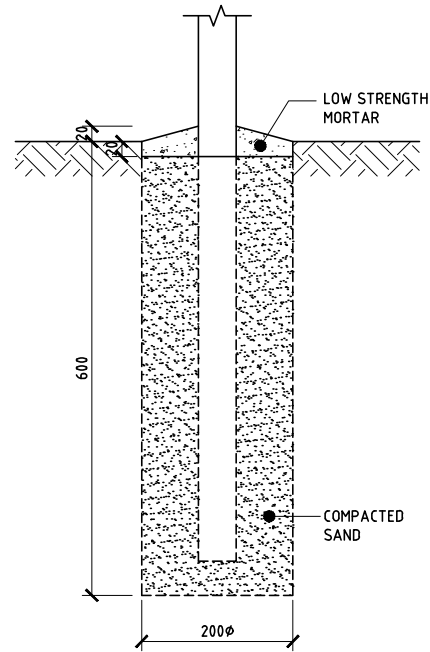
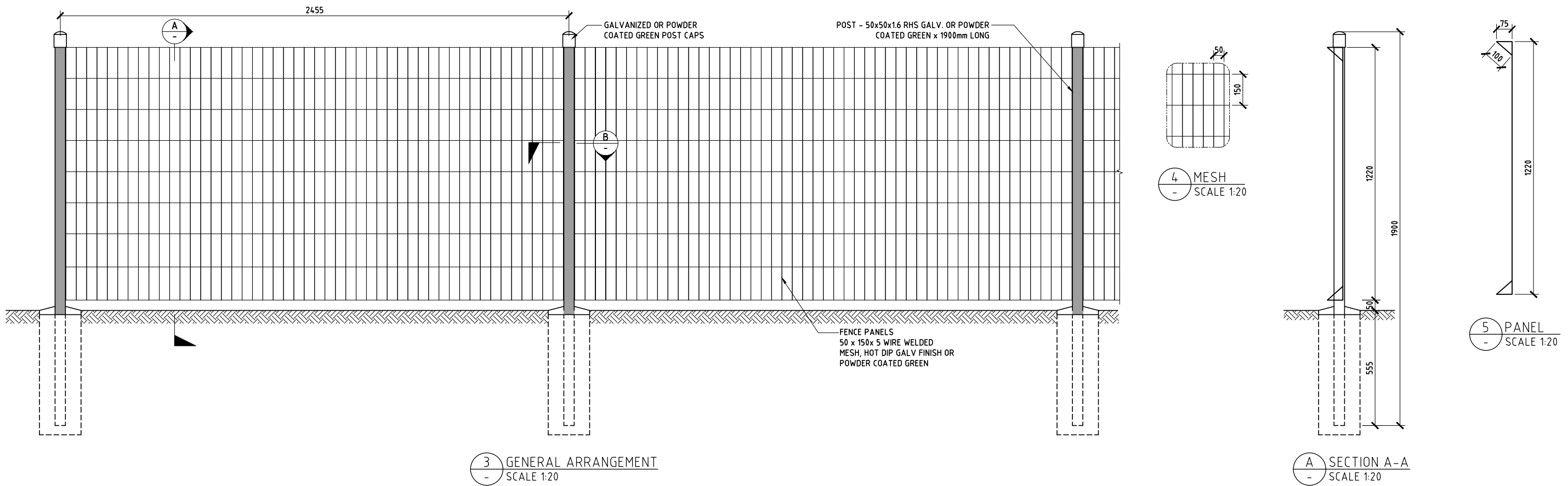

6 POST HOLE SET IN SOIL SCALE 1:10

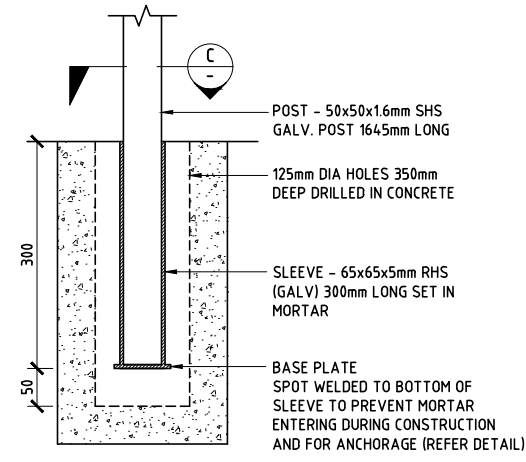

7 POST HOLE SET IN EXISTING CONCRETE SCALE 1:10

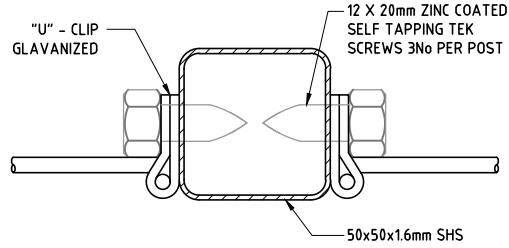

B SECTION B-B SCALE 1:10

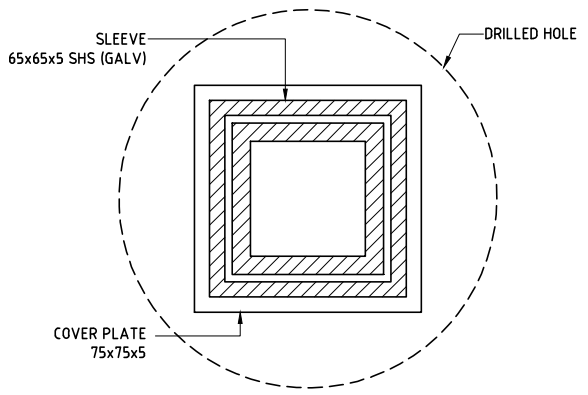

C SECTION C-C SCALE 1:10

- GENERAL NOTES
1. THE FENCE UTILIZES "A.R.C." 1220 x 2400 JACARANDA PANELS.
  2. ELECTRICAL INSULATION DETAILS FOR FENCES IN THE VICINITY OF TRANSMISSION LINES AND TOWERS REFER SD 3171.
  3. ALL DIMENSIONS ARE IN MILLIMETERS.

STANDARD DRAWINGS

FENCE WELDED MESH



ISSUE	APP'D	DATE	AMENDMENT	BY
E				
D				
C				
B				
A				

SCALE	DATE	DESIGN BY	DRAWN BY	APPROVED	DRAWING No.	SHEET No.	ISSUE
	11 March 19		S VOLAU		R 704 - 1	01	

# STANDARD ARROW DIMENSIONS

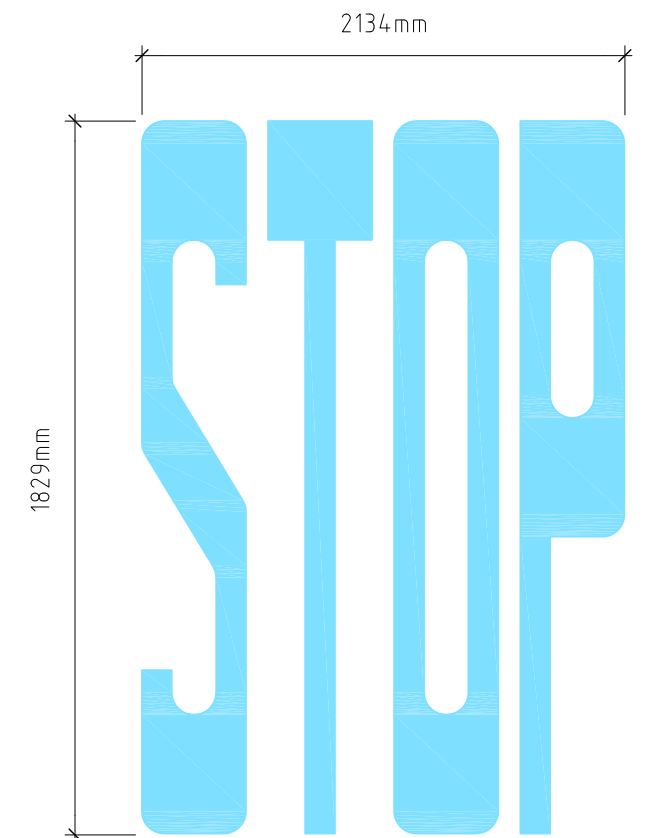
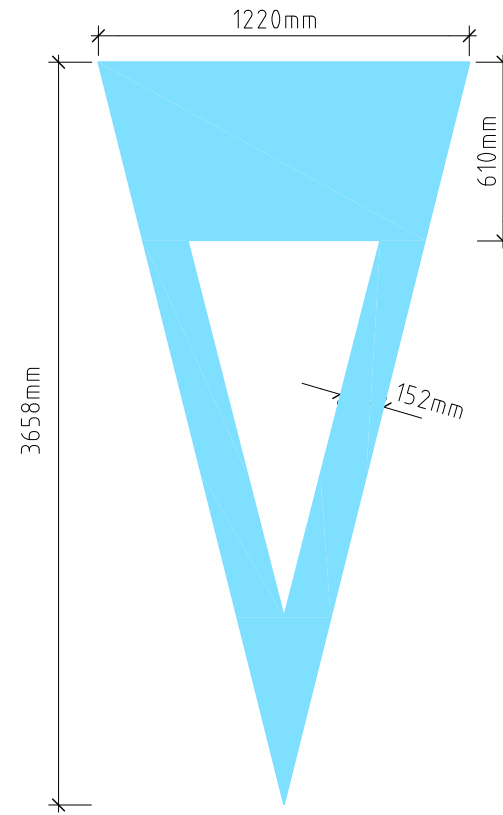
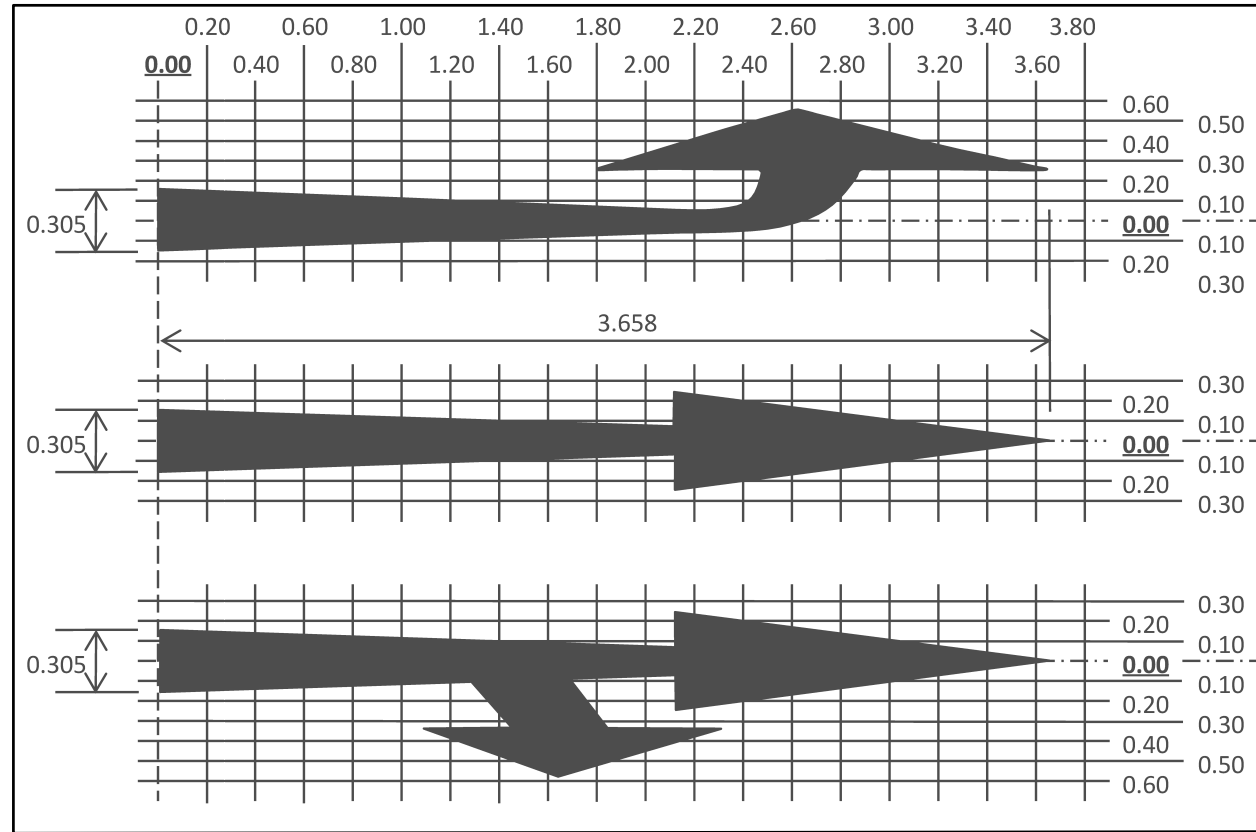

SCALE : NTS

# ROADMARKING DETAIL

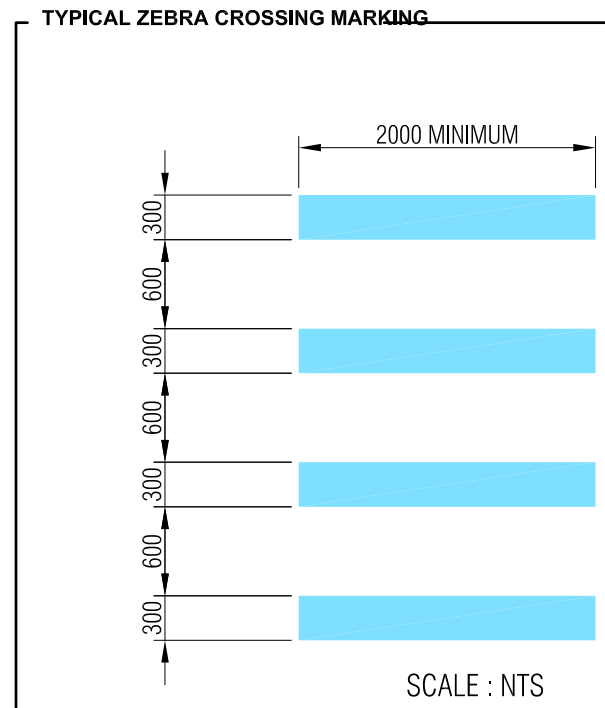
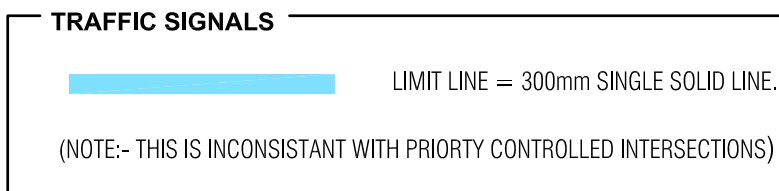
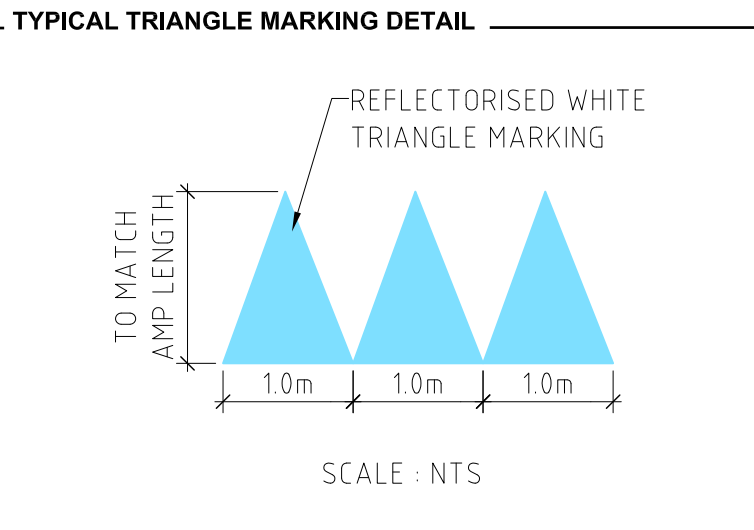
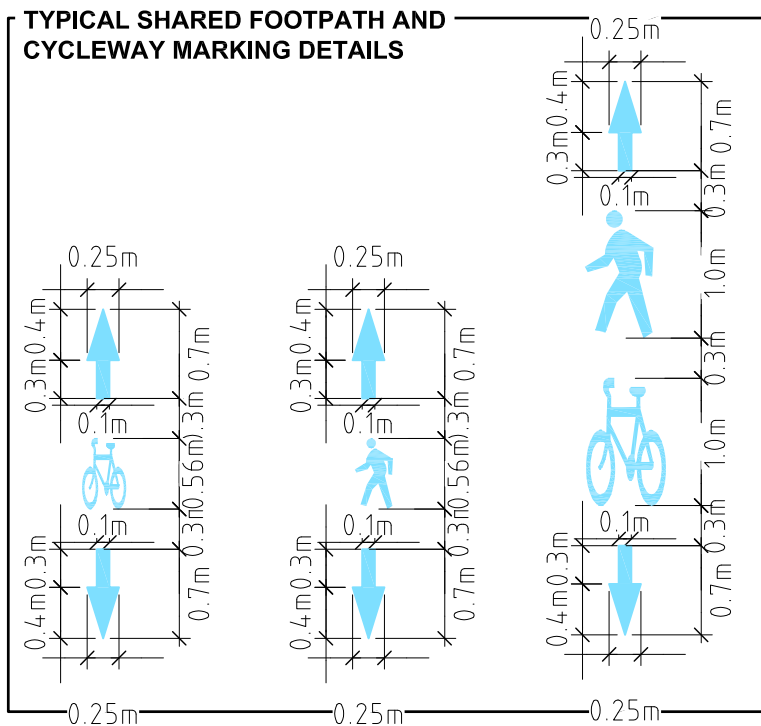

- ### NOTES
- ALL RETRO REFLECTIVE SHEETING USED FOR TRAFFIC SIGNS SHALL BE CLASS 1 AND MUST CONFORM TO THE COLOUR REQUIREMENTS OF AS/NZS 1906.1 AND 1906.2 2009.
  - ALL TRAFFIC SIGNS SHALL BE FITTED WITH INTEGRATED STIFFENER CHANNELS AND BRACKETS FOR INSTALLATION ON POSTS IN COMPLIANCE WITH RSMA.
  - ROAD MARKINGS ARE BASED ON THE FIJI SIGNS AND PAVEMENT MARKING INTERIM MANUAL, 1992

150  
100  
50  
30  
20  
10  
A3 ORIGINAL SIZE  
ISSUE APPD DATE AMENDMENT BY

E				
D				
C				
B				
A				
ISSUE	APPD	DATE	AMENDMENT	BY

GENERAL NOTES

STANDARD DRAWINGS  
PAVEMENT MARKING TYPICAL DETAIL

SCALE	DATE	DESIGN BY	DRAWN BY	APPROVED	DRAWING No.	SHEET No.	ISSUE
	05 April 17		CWS		R 705 - 1	01	

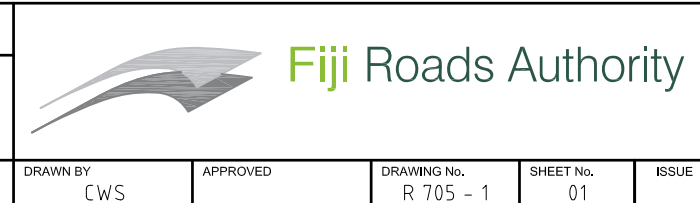

PLOT DATE 19/10/2018

150  
100  
50  
40  
30  
20  
10

A3 ORIGINAL SIZE

TYPICAL BUS BAY MARKING DETAIL

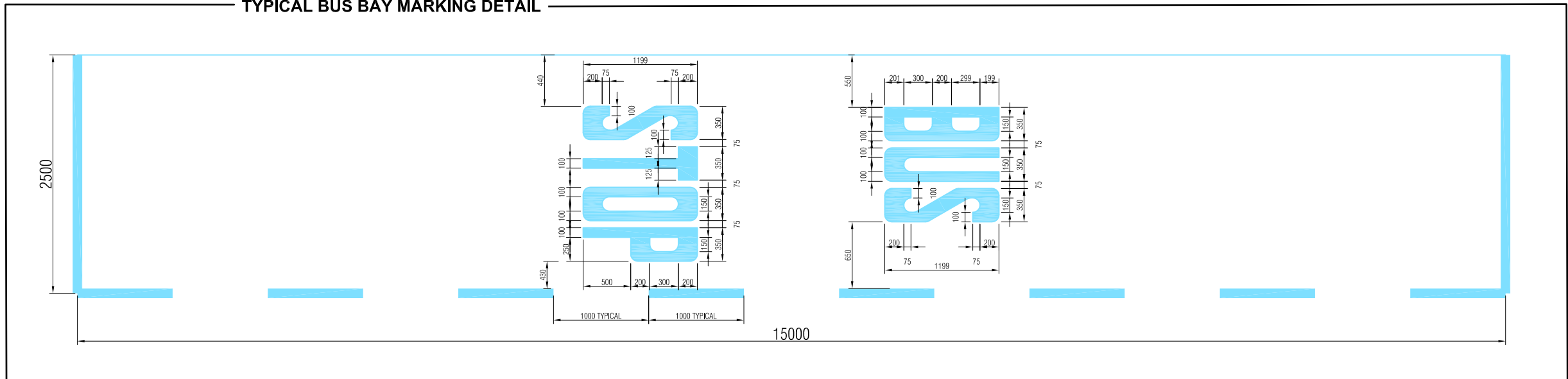

TYPICAL ROADMARKING DETAIL

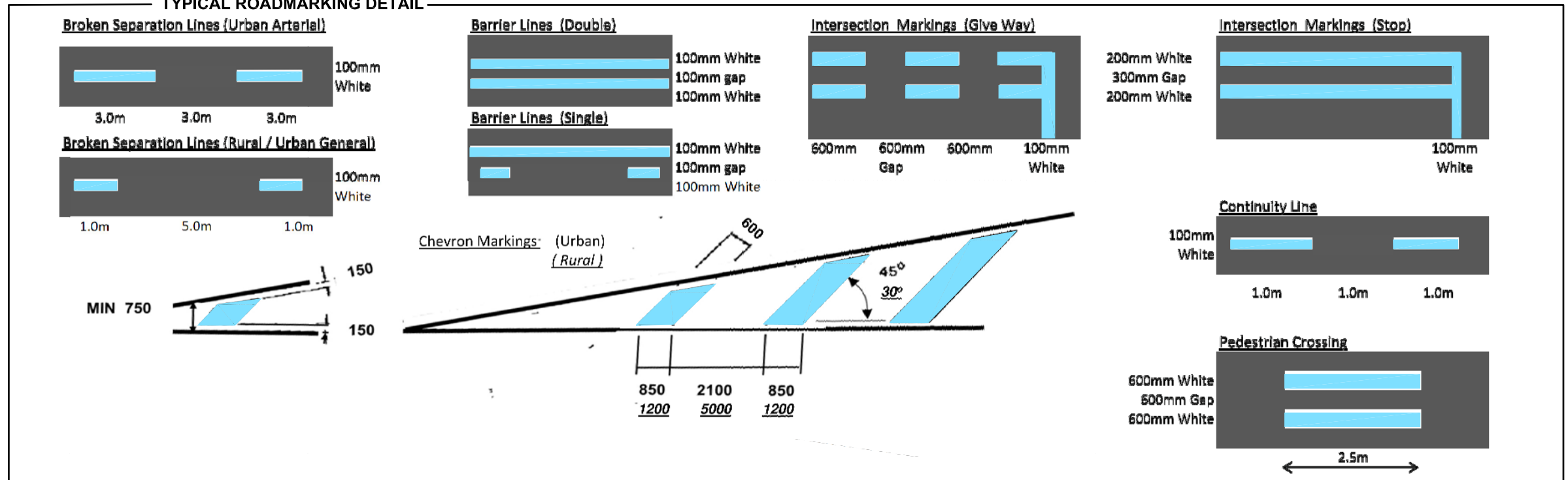

TRAFFIC SIGNALS

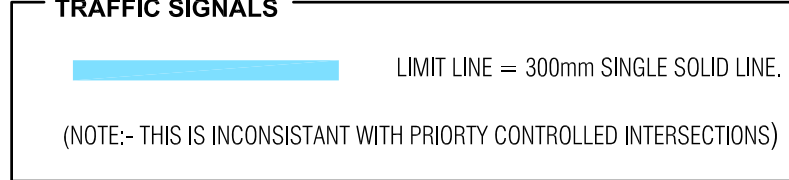

NOTES

1. ALL RETRO REFLECTIVE SHEETING USED FOR TRAFFIC SIGNS SHALL BE CLASS 1 AND MUST CONFORM TO THE COLOUR REQUIREMENTS OF AS/NZS 1906.1 AND 1906.2 2009.
2. ALL TRAFFIC SIGNS SHALL BE FITTED WITH INTEGRATED STIFFENER CHANNELS AND BRACKETS FOR INSTALLATION ON POSTS IN COMPLIANCE WITH RSMA.
3. ROAD MARKINGS ARE BASED ON THE FIJI SIGNS AND PAVEMENT MARKING INTERIM MANUAL, 1992

E				
D				
C				
B				
A				
ISSUE	APPD	DATE	AMENDMENT	BY

GENERAL NOTES

STANDARD DRAWINGS  
PAVEMENT MARKING TYPICAL DETAIL

SCALE	DATE	DESIGN BY	DRAWN BY	APPROVED	DRAWING No.	SHEET No.	ISSUE
	05 April 17		CWS		R 705 - 2	02	

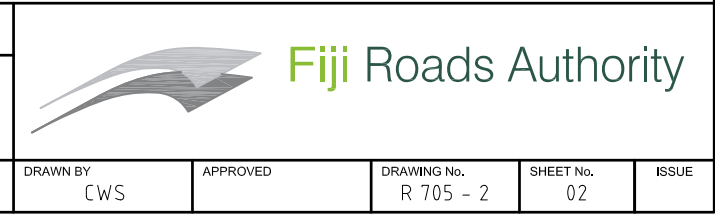

A3 ORIGINAL SIZE

150

100

50

40

30

20

10

PLOT DATE 19/10/2018

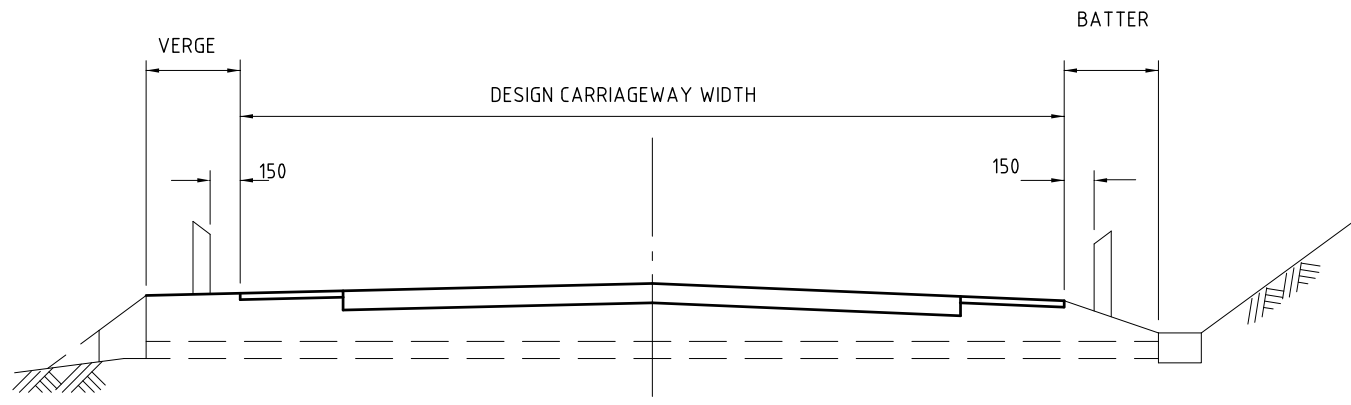
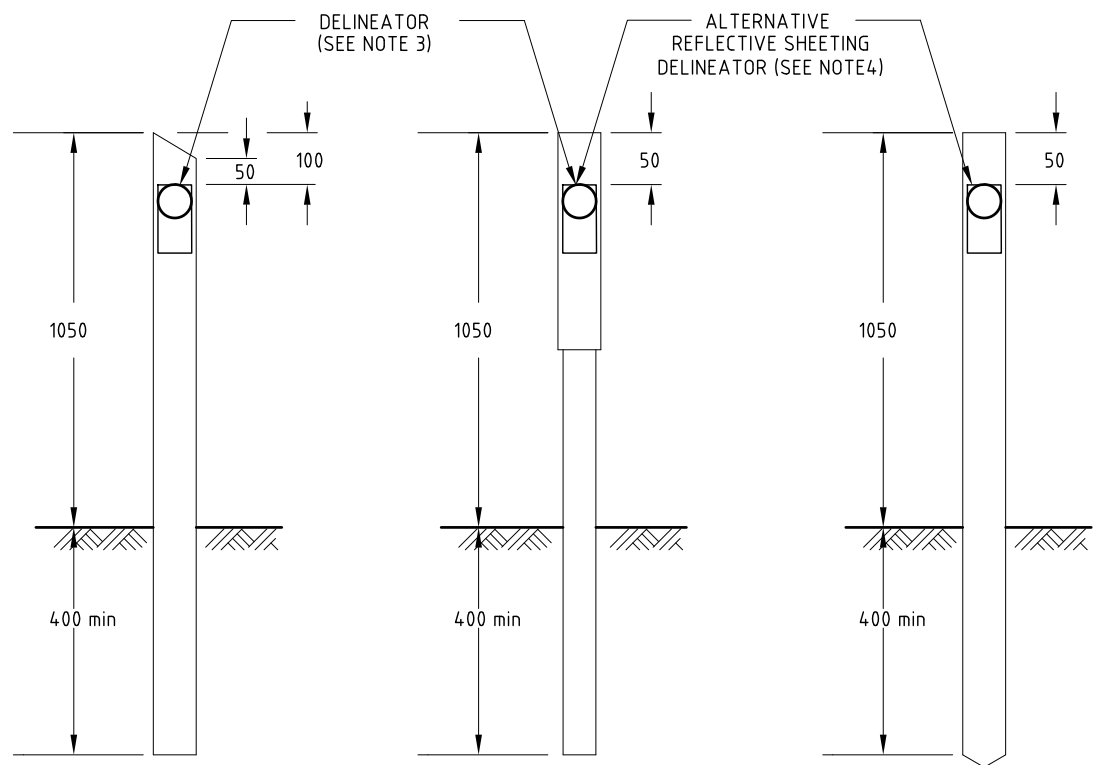

LATERAL LOCATION OF GUIDE POSTS

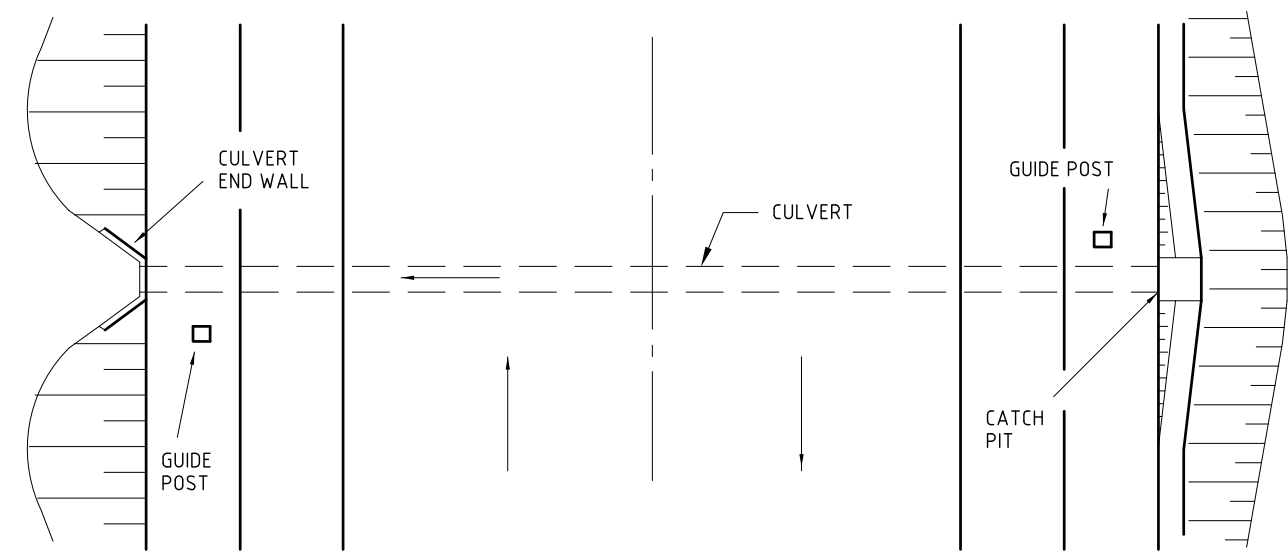
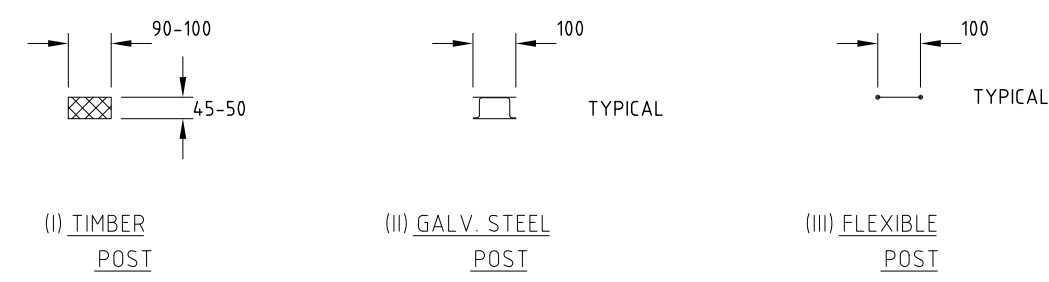

LOCATION OF CULVERT GUIDE POSTS

NOTES:

- THE FOLLOWING TYPES OF GUIDE POST ARE AVAILABLE
  - (I) TIMBER POSTS: 100x50mm (nominal) CROSS-SECTION, PAINTED WHITE. SEE DIAGRAM (I).
  - (II) GALVANIZED STEEL POSTS: OF APPROVED CROSS-SECTION WITH 100x50mm WHITE DELINEATOR PLATE ATTACHED. SEE DIAGRAM (II).
  - (III) FLEXIBLE POST: 100mm WIDE WHITE PLASTIC OR FIBREGLASS STRIP OF APPROVED TYPE, CAPABLE OF SELF-RECOVERY AFTER KNOCKDOWN. SEE DIAGRAM (III).
- THE STANDARD DELINEATOR IS THE 80mm DIA CIRCULAR CORNER-CUBE TYPE, RED OR WHITE, CONFORMING WITH THE "TYPE A" DELINEATOR SPECIFIED IN AS 1906, PART 2.
- WHERE SPECIFIED ON THE DRAWING, SHEETING TYPE DELINEATORS CAN BE USED IN PLACE OF THE STANDARD DELINEATORS. THE SHEETING SHALL HAVE A TOTAL MINIMUM REFLECTIVE OUTPUT EQUIVALENT TO 100cm OF CLASS 1A OF CLASS 1A RETROREFLECTIVE MATERIAL AS DEFINED IN AS/NZS 1906, PART 1. THE WIDTH OF REFLECTIVE MATERIAL SHALL BE 40mm MINIMUM. ONLY ONE TYPE OF DELINEATOR SHALL BE USED AT ANY ONE LOCATION.
- WHERE LOCATED ON A KERBBED CARRIAGEWAY, GUIDE POSTS SHALL BE INSTALLED 600mm BEHIND FACE OF KERB.

E				
D				
C				
B				
A				
ISSUE	APPD	DATE	AMENDMENT	BY

GENERAL NOTES

STANDARD DRAWINGS	
GUIDE POSTS	
SCALE	DATE
	05 April 17
DESIGN BY	

Fiji Roads Authority

DRAWN BY	APPROVED	DRAWING No.	SHEET No.	ISSUE
CWS		R 705 - 3	02	

Table 2: Bedding Material

Material Size	Nominal Diameter (mm)
D <sub>15</sub>	50
D <sub>50</sub>	150
D <sub>85</sub>	200

Table 1: Rock Rip Rap Grading

Nominal Diameter (mm)	
Material Size	Type 1 Rip rap
D <sub>min</sub>	300
D <sub>15</sub>	400
D <sub>50</sub>	800
D <sub>85</sub>	1000
D <sub>max</sub>	1200

Table 1: Rock Rip Rap Grading

Material Size	Nominal Diameter (mm)			
	Type 1 Rip Rap	Type 2 Rip Rap	Type 3 Rip Rap	Type 4 Rip Rap
D <sub>min</sub>	300	350	400	500
D <sub>15</sub>	400	450	500	600
D <sub>50</sub>	800	1000	1200	1500
D <sub>85</sub>	1000	1250	1600	2000
D <sub>max</sub>	1200	1500	1800	2250

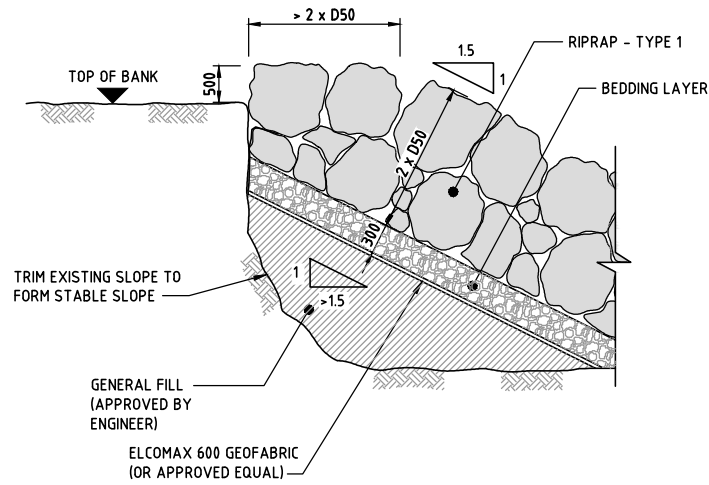

CREST DETAIL

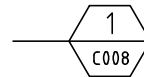

SCALE: NTS

(WHEN ADJACENT TO ERODED BANK)

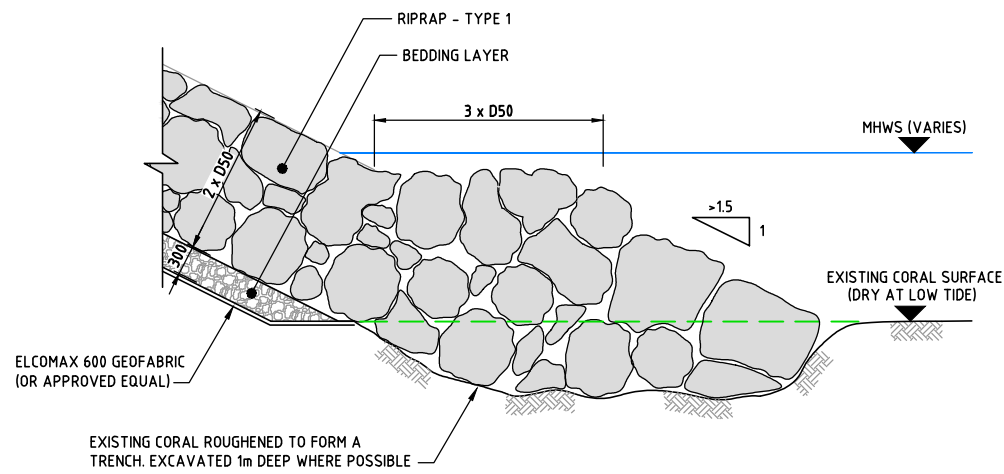

ALTERNATIVE TOE DETAIL



SCALE: NTS

(WHEN UPON CORAL)

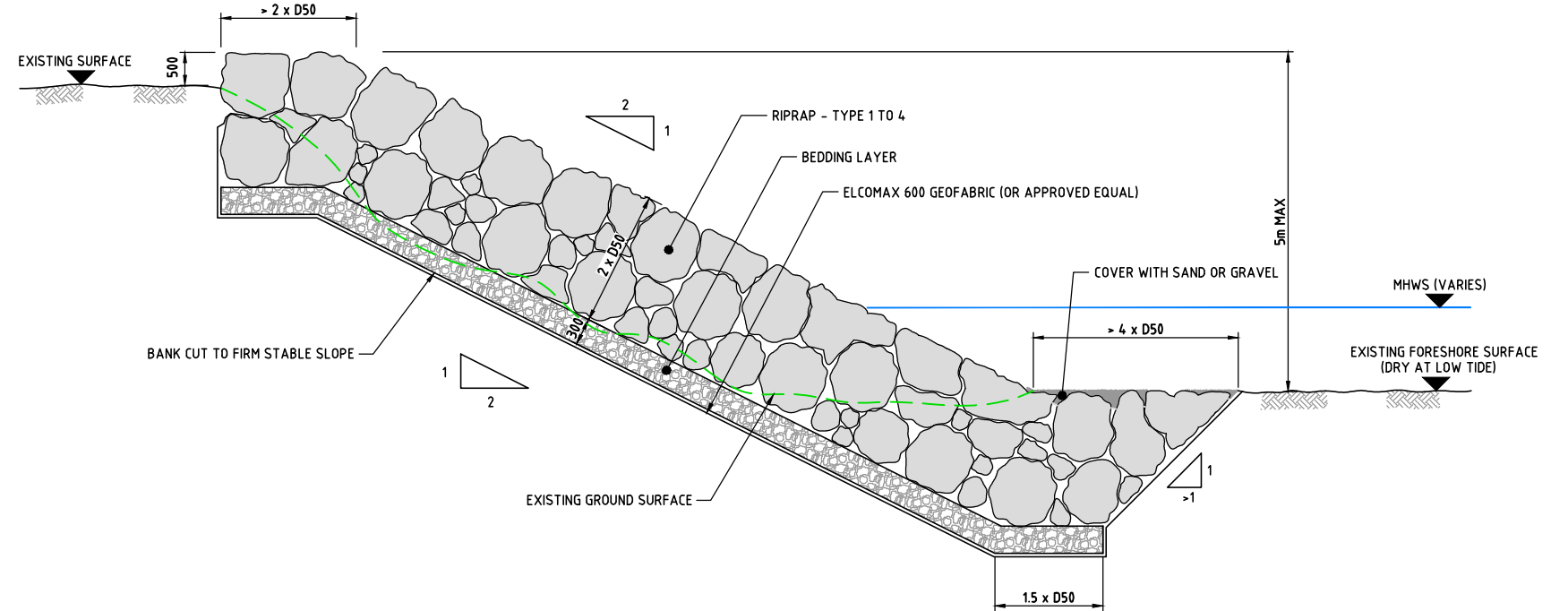

TYPICAL SECTION A

SCALE: NTS

(WHEN CREST ADJACENT TO BANK IN CUT AND TOE IS WITHIN SAND/GRAVEL BEACH)

PLOT DATE 12/03/2019

150

100

50

40

30

20

10

A3 ORIGINAL SIZE

ISSUE	APP'D	DATE	AMENDMENT	BY
E				
D				
C				
B				
A				

GENERAL NOTES

- Where it is not proposed to use sand bedding, FRA approval shall be sought for adoption of a stronger geotextile to prevent puncturing by the rocks
- Rock Bedding shall comply with Standard Specification Section 606

STANDARD DRAWINGS				
COASTAL REVETMENT DETAIL				
SCALE	DATE	DESIGN BY	DRAWN BY	APPROVED
	05 April 17		CWS	



DRAWING No.	SHEET No.	ISSUE
R 705 - 4	01	

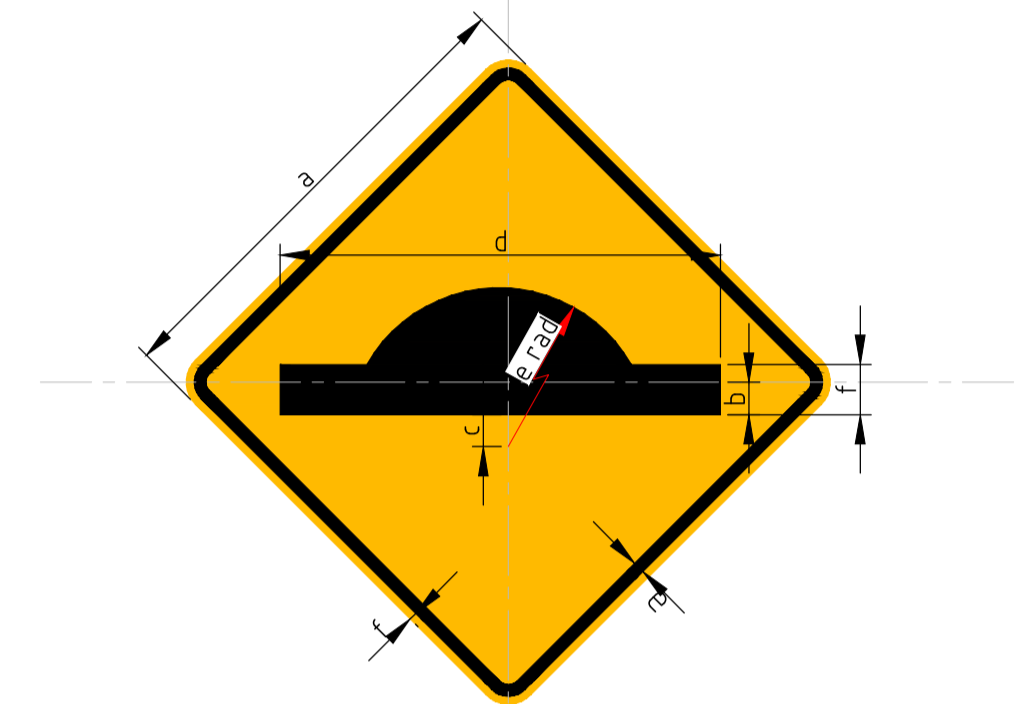
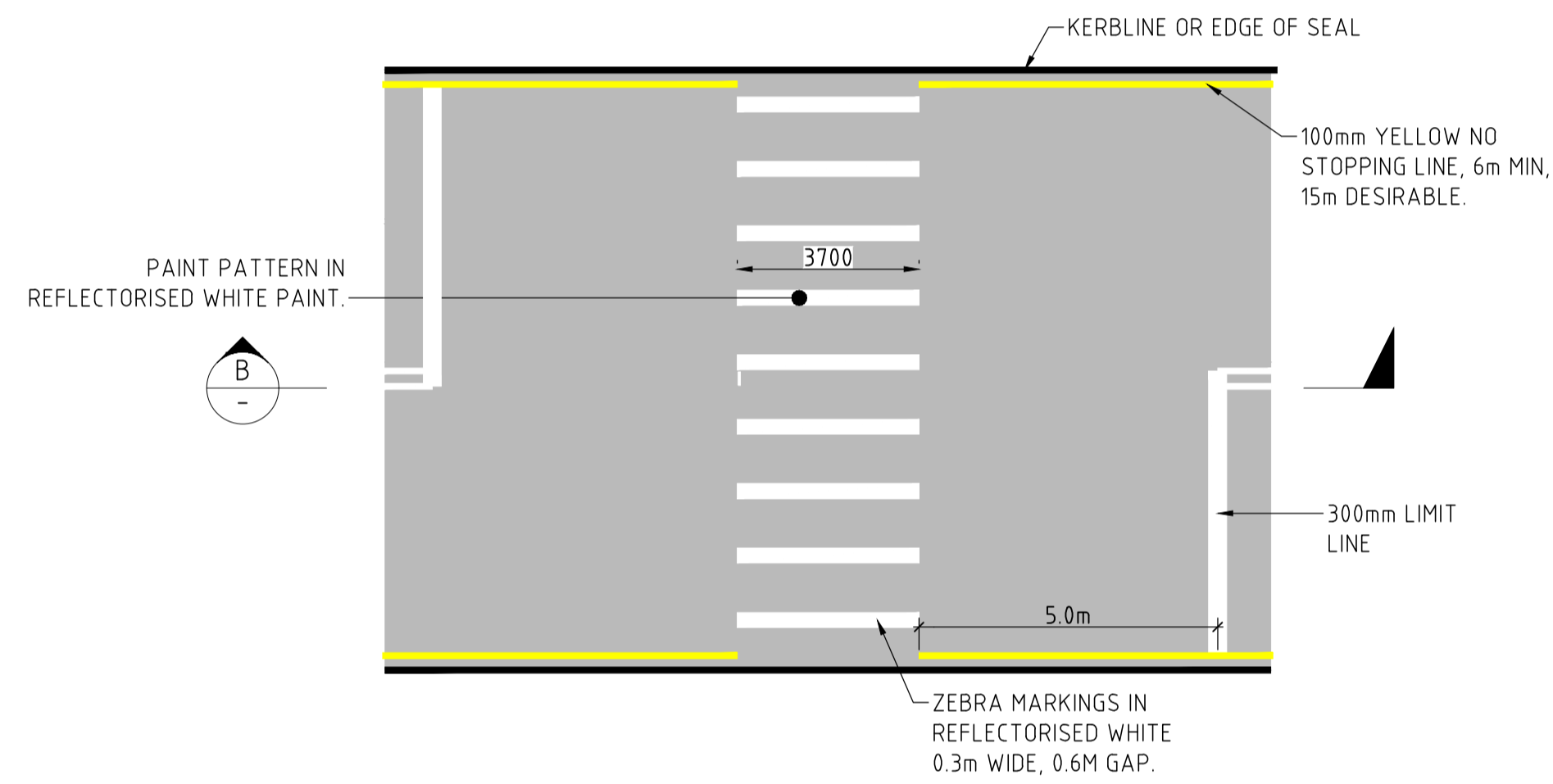
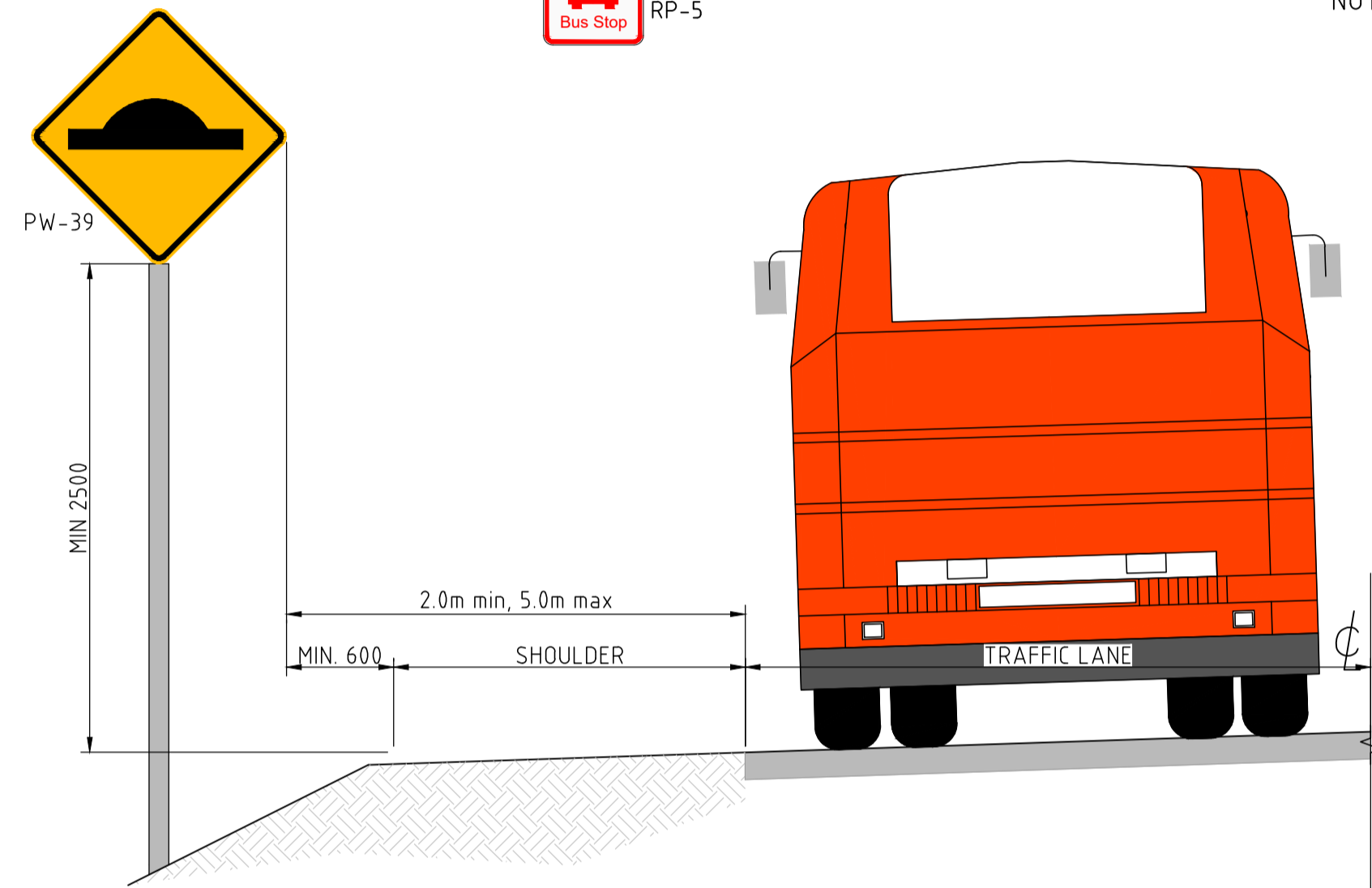
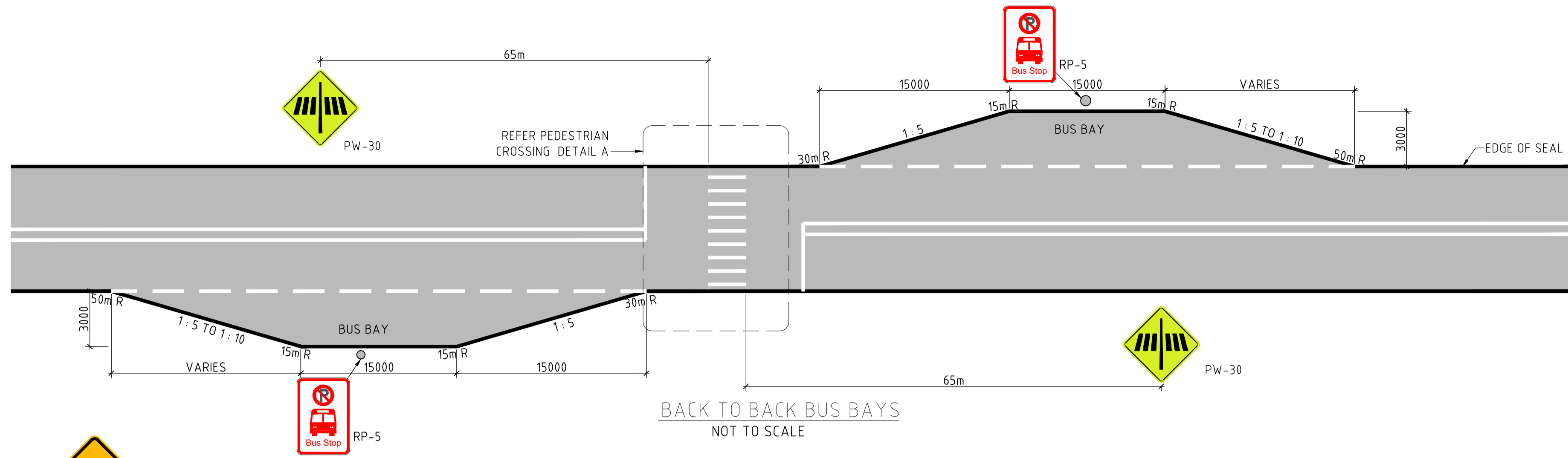

PW-39	
r	50
h	13
g	19
f	75
e	250
d	700
c	50
b	50
a	750

NOTE:

- BACKGROUND TO BE REFLECTORISED YELLOW.
- BORDER TO BE IN BLACK.
- REVERSE SIDE TO BE BLACK.

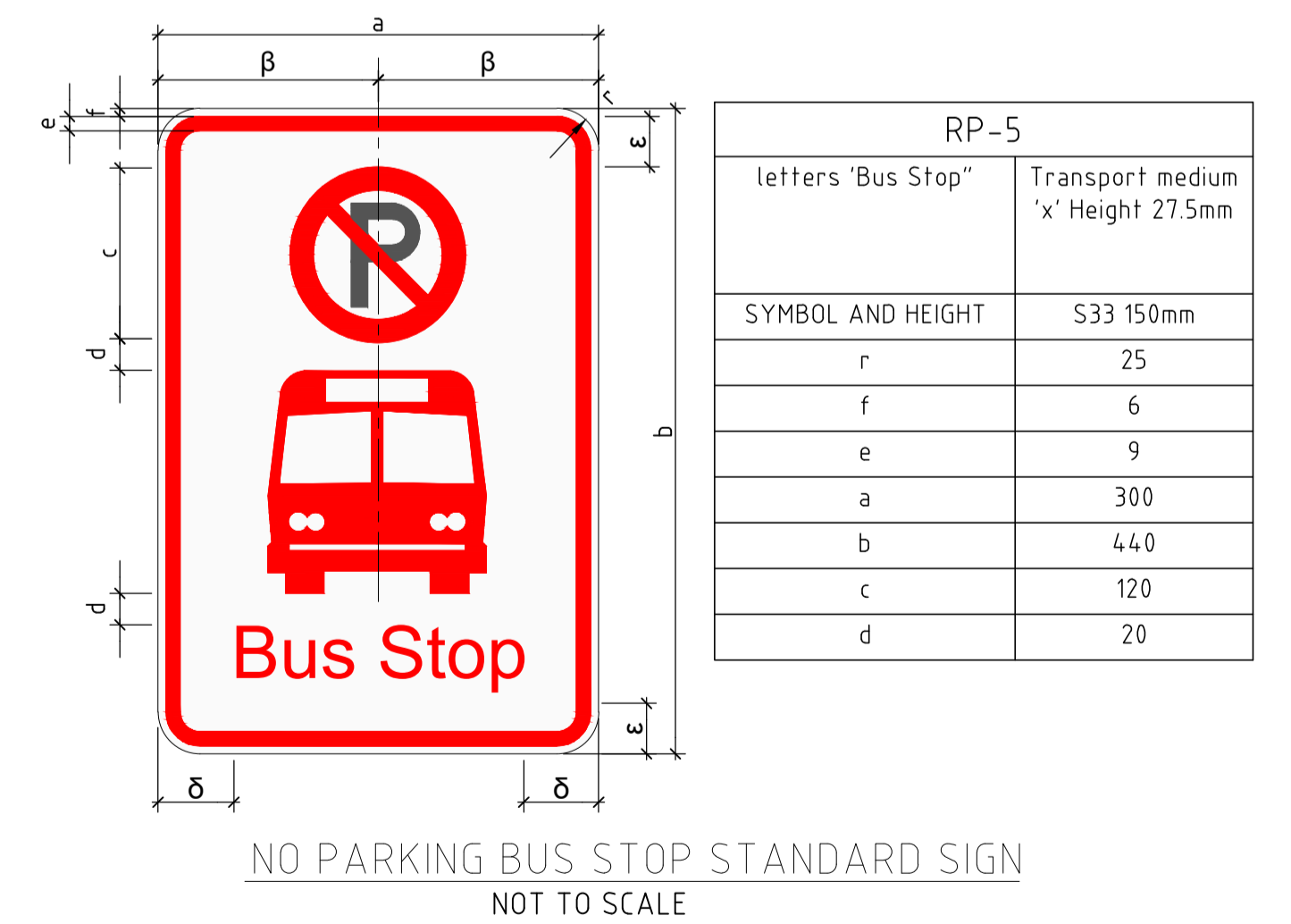
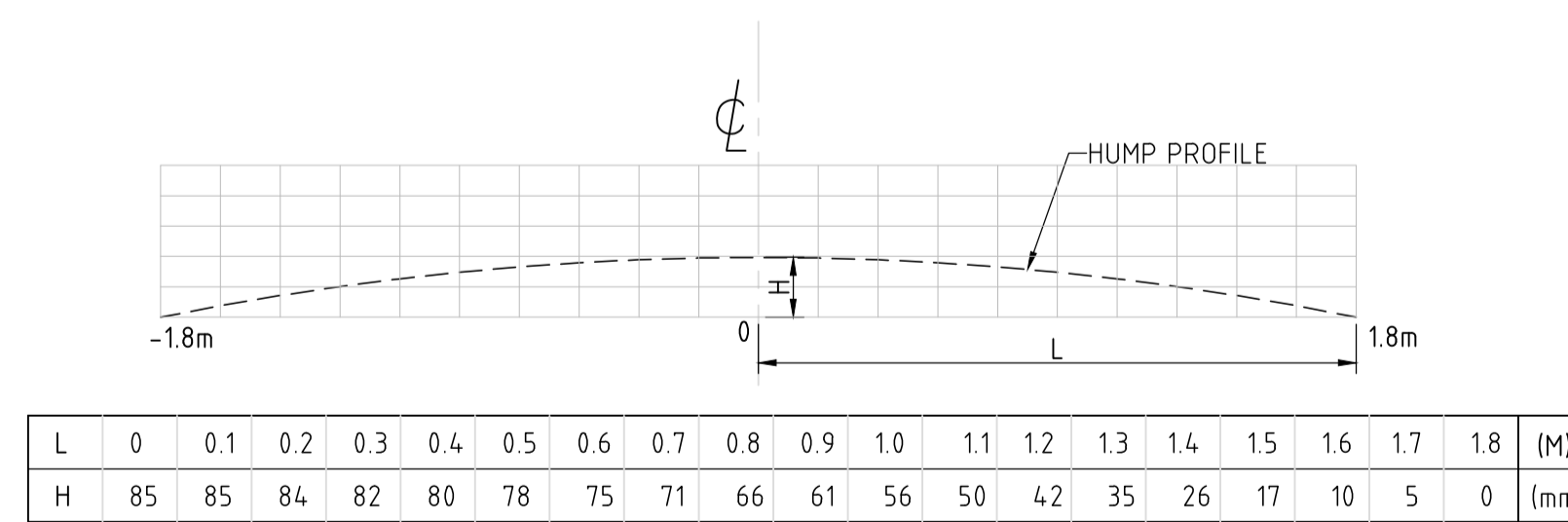
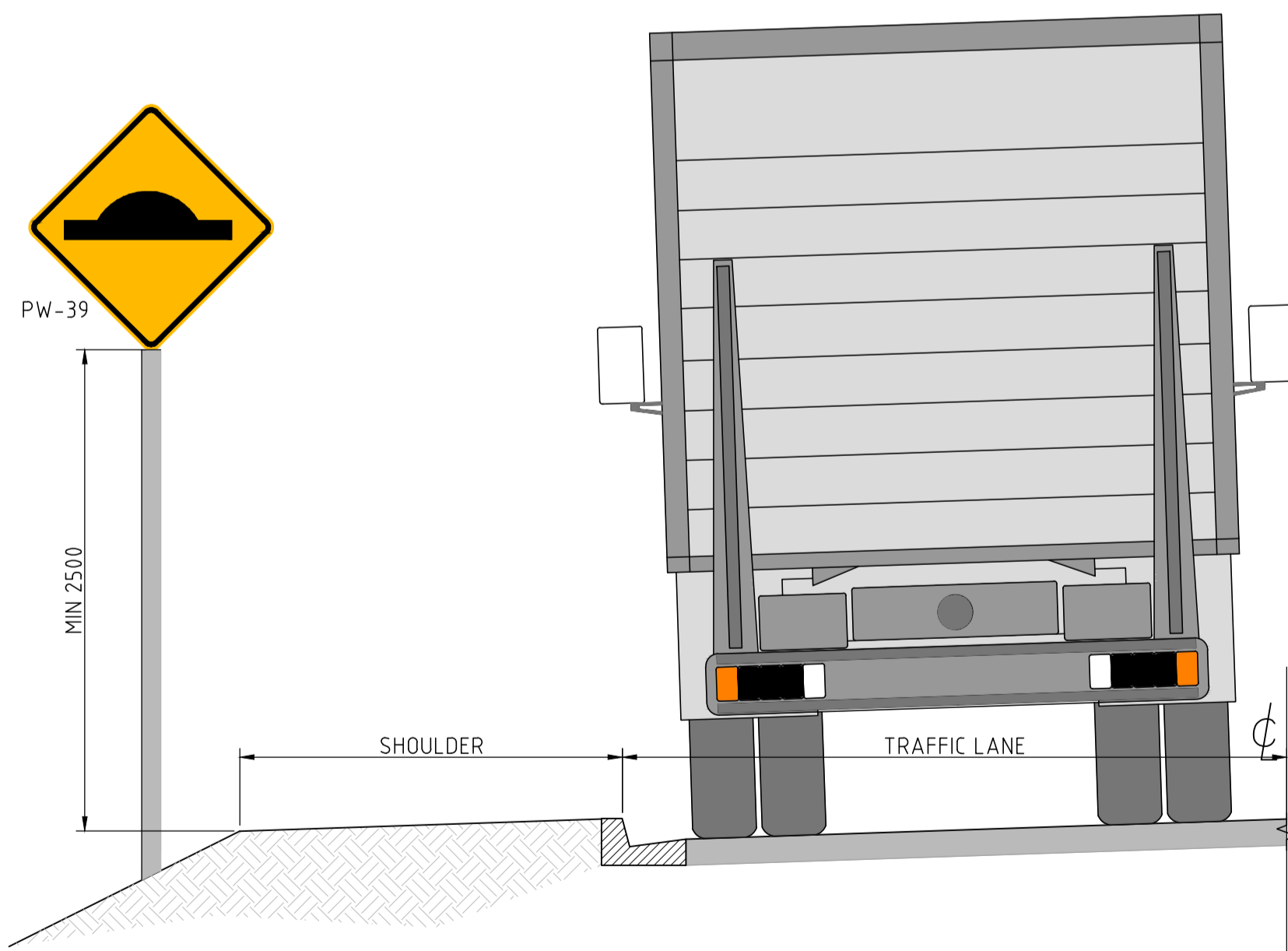

- NOTES
- ROAD PAVEMENTS MAY BE MARKED BY ONE OR MORE OF THE FOLLOWING MATERIALS:
    - PAINT - WITH GLASS BEADS EMBEDDED OR PREMIXED (SEE AS 4049.1).
    - THERMOPLASTICS OR OTHER APPLIED IN SITU PLASTICS MATERIALS - WITH REFLECTIVE PROPERTIES.
    - PRECUT SHEETING - WITH REFLECTIVE PROPERTIES.
  - ALL SIGN FACE MATERIALS SHALL COMPLY WITH THE DAY TIME VIEWING COLOR REQUIREMENTS AND BE RETROREFLECTIVE WITH THE PHOTOMETRIC PROPERTIES AND NIGHT -TIME VIEWING COLOR REQUIREMENTS OF AS/NZS 1906.1:2007 AND 1906.2:2007 - RETROREFLECTIVE MATERIALS AND DEVICES FOR ROAD TRAFFIC CONTROL PURPOSES
  - WHERE A SERIES OF HUMPS ARE INSTALLED, THEN EACH HUMP SHOULD BE SEPARATELY SIGNED.
  - INSTALLATION OF SPEED CONTROL HUMPS (NEW OR REPLACEMENT OF EXISTING) SHALL BE APPROVED BY FIJI ROADS AUTHORITY AND/ OR THEIR REPRESENTATIVE.
  - PROVISION OF PEDESTRIAN CROSSING IS BASED ON THE SELECTION WARRANTS DETAILED IN AS1742.10 OR AS DIRECTED BY FRA OR THEIR REPRESENTATIVE

A3 ORIGINAL SIZE

ISSUE	APPD	DATE	AMENDMENT	BY
E				
D				
C				
B				
A				

GENERAL NOTES

STANDARD DRAWINGS  
TYPICAL DETAILS  
HUMP SIGNAGES & FLAT TOP HUMP

SCALE: \_\_\_\_\_ DATE: 19 NOVEMBER 19 DESIGN BY: \_\_\_\_\_

DRAWN BY: CWS APPROVED: \_\_\_\_\_  
 DRAWING No. R 705 - 5 SHEET No. 01 ISSUE: \_\_\_\_\_

PLOT DATE 07/10/2019

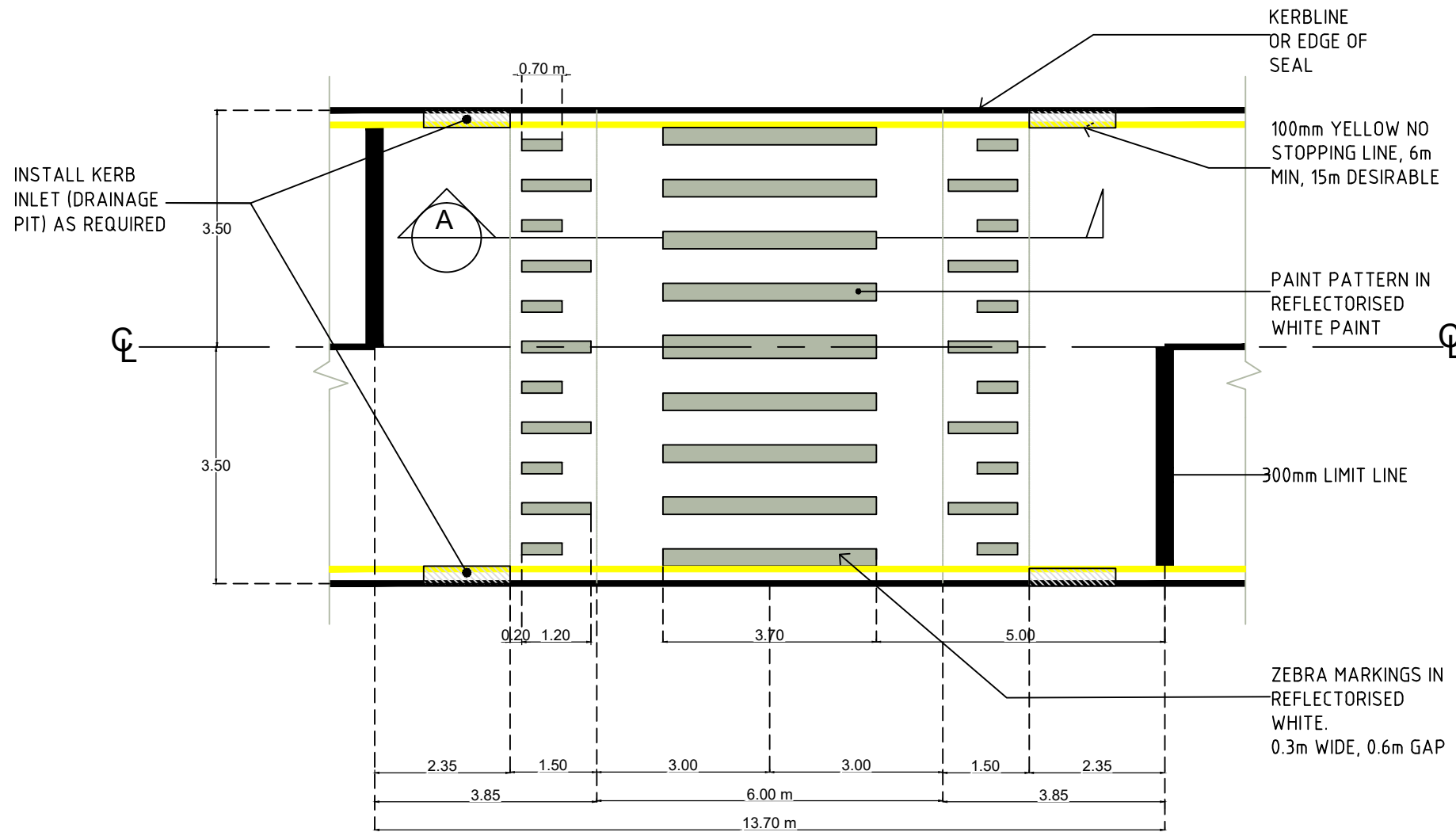

OPERATING SPEED (km/hr)	DIVIDED CARRIAGEWAY		UNDIVIDED CARRIAGEWAY	
	APPROACH RAMP GRADE	COMFORTABLE MAX. SPEED (km/hr)	APPROACH/DEPARTURE RAMP GRADE	COMFORTABLE MAX. SPEED (km/hr)
50	1:15 (6.7%)	30 <sup>x</sup>	1:20 (5%)	40
60	1:20 (5%)	40	1:25 (4%)	50
70	1:25 (4%)	50	1:25 <sup>*</sup> (4%)	50

**NOTE:**

- SPECIFICATION REFERS TO VICROADS RDN 03-07 FOR RAISED SAFETY PLATFORMS (RSPs).
- SECTION A-A RELATES TO FRA'S STANDARD DRAWING DOCUMENT DRAWING NO. R705 - 5.
- <sup>x</sup> DESIRED MAX. SPEED FOR A PEDESTRIAN OR CYCLIST RELATED CRASH.
- <sup>\*</sup> MAY RESULT IN INCREASED MOTORIST DISCOMFORT, CONSULT VICROADS SSE TEAM FOR FURTHER GUIDANCE.
- REFER TO VICROADS SUPPLEMENT TO AUSTRROADS GUIDE TO ROAD DESIGN PART 3 FOR THE DEFINITION OF "OPERATING SPEED".

**RAISED PEDESTRIAN CROSSING DETAIL**

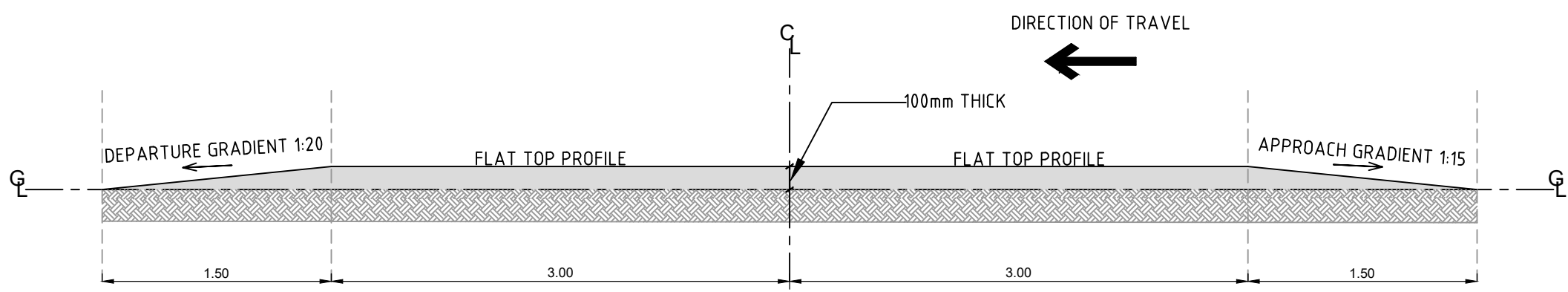

**SECTION A-A**

E				
D				
C				
B				
A				
ISSUE	APPD	DATE	AMENDMENT	BY

GENERAL NOTES

STANDARD DRAWINGS		
RAISED PEDESTRIAN CROSSING		
SCALE	DATE	DESIGN BY
	04 SEPTEMBER 19	

DRAWN BY	APPROVED	DRAWING No.	SHEET No.	ISSUE
S.FREMLIN	M. J. DALE	R 705 - 6	01	

**SERIES 800      UTILITY SERVICES LAYOUT**

DRAWING NUMBER	DRAWING TITLE
R 800 - 1	TYPICAL LAYOUT UNDERGROUND DUCTING
R 800 - 2	TYPICAL LAYOUT UNDERGROUND CONDUIT WARNING SIGN
R 800 - 3	CABLE PIT FORMER STANDARD 600mm DIA.
R 800 - 4	HEAVY DUTY CABLE PIT AND COVER
R 800 - 5	TYPICAL LAYOUT TRUNK CONDUIT SYSTEM FOR MAIN ROADS
R 800 - 6	TYPICAL LAYOUT TRUNK CONDUIT SYSTEM FOR MAIN ROADS
R 800 - 7	TYPICAL LAYOUT UTILITIES CONDUIT ALIGNMENT & COLOR CODING

---

PLOT DATE 23/02/2018

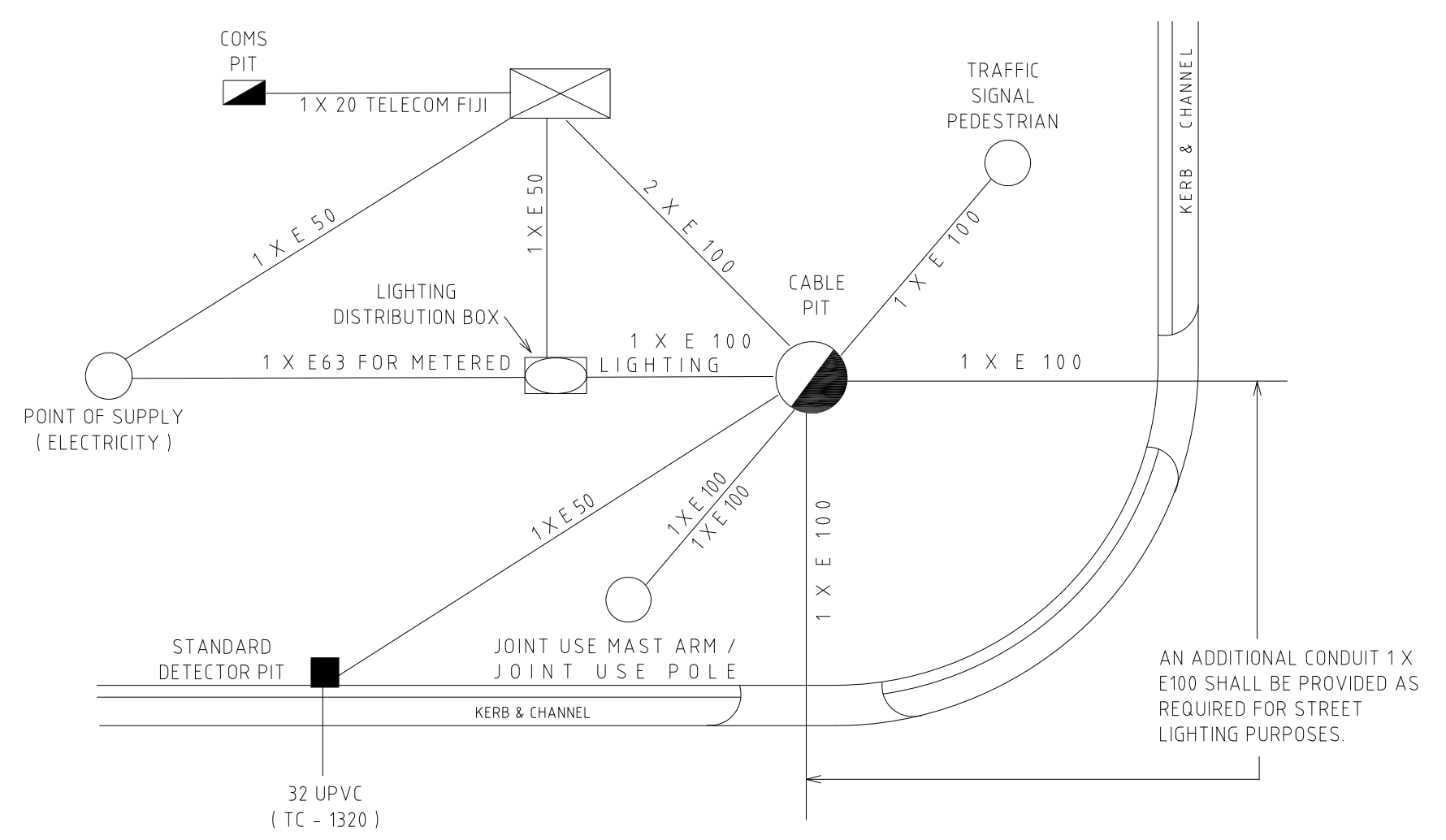

CONDUIT

TYPE	SIZE
MAIN ELECTRICAL CIRCUIT	100
STREET LIGHTING	100
POWER SUPPLY TO CONTROLLER	50
POWER SUPPLY TO LIGHTING	63
DETECTOR CONDUIT	50
LINKING (AS REQUIRED)	50
TELECOM FIJI LIMITED	20

LOCATION	DEPTH
DETECTOR / COMMS CONDUITS ALL SURFACES	205
ELECTRICAL CONDUITS	
FOOTPATH & UNPAVED	600
UNCLASSIFIED ROAD	600
DECLARED ROADS	1200
TRAM TRACKS	1200
RAIL TRACKS	2000

NOTES:

1. UNDERGROUND CONDUITS TO BE HEAVY DUTY RIGID PVS. (ORANGE FOR ELECTRICAL, WHITE FOR COMMUNICATIONS).
2. TRENCHING BENEATH ROAD AREAS TO BE BACKFILLED AND COMPACTED AS SPECIFIED SEPARATELY.
3. WHEN FRA DISTRIBUTION CABINET INSTALLED, POINT OF SUPPLY FOR TRAFFIC SIGNALS TO BE TAKEN FROM DISTRIBUTION CABINET.

A3 ORIGINAL SIZE

ISSUE	APPD	DATE	AMENDMENT	BY
E				
D				
C				
B				
A				

GENERAL NOTES

**STANDARD DRAWINGS**

TYPICAL LAYOUT  
UNDERGROUND DUCTING

SCALE SCALE 1:100

DATE 30 MAR 17

**Fiji Roads Authority**

DESIGN BY	DRAWN BY	APPROVED	DRAWING No.	SHEET No.	ISSUE
	TT	A KETENILAGI	FRA-R 800-01	01	A

PLOT DATE 25/02/2018

150  
100  
50  
40  
30  
20  
10

A3 ORIGINAL SIZE

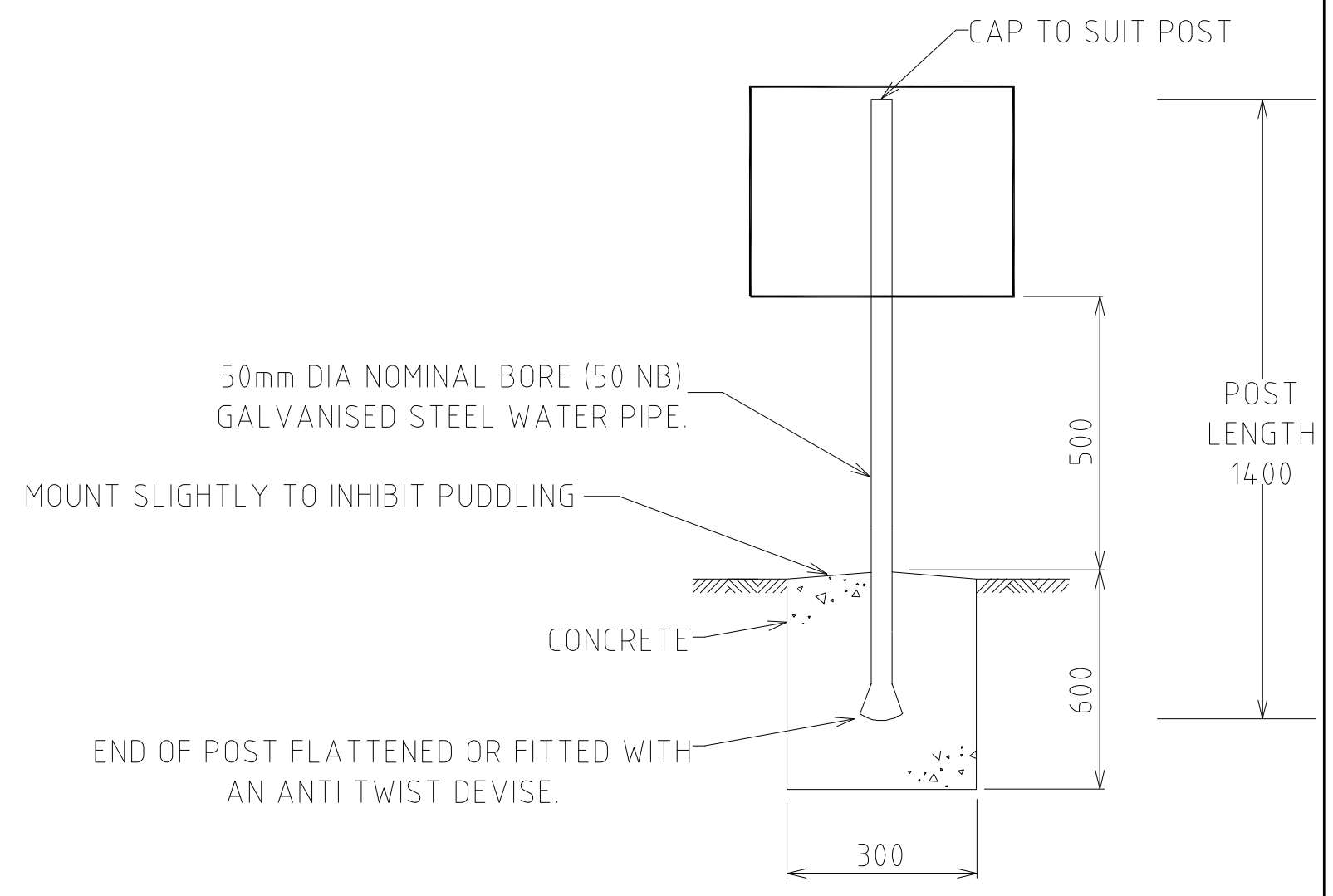
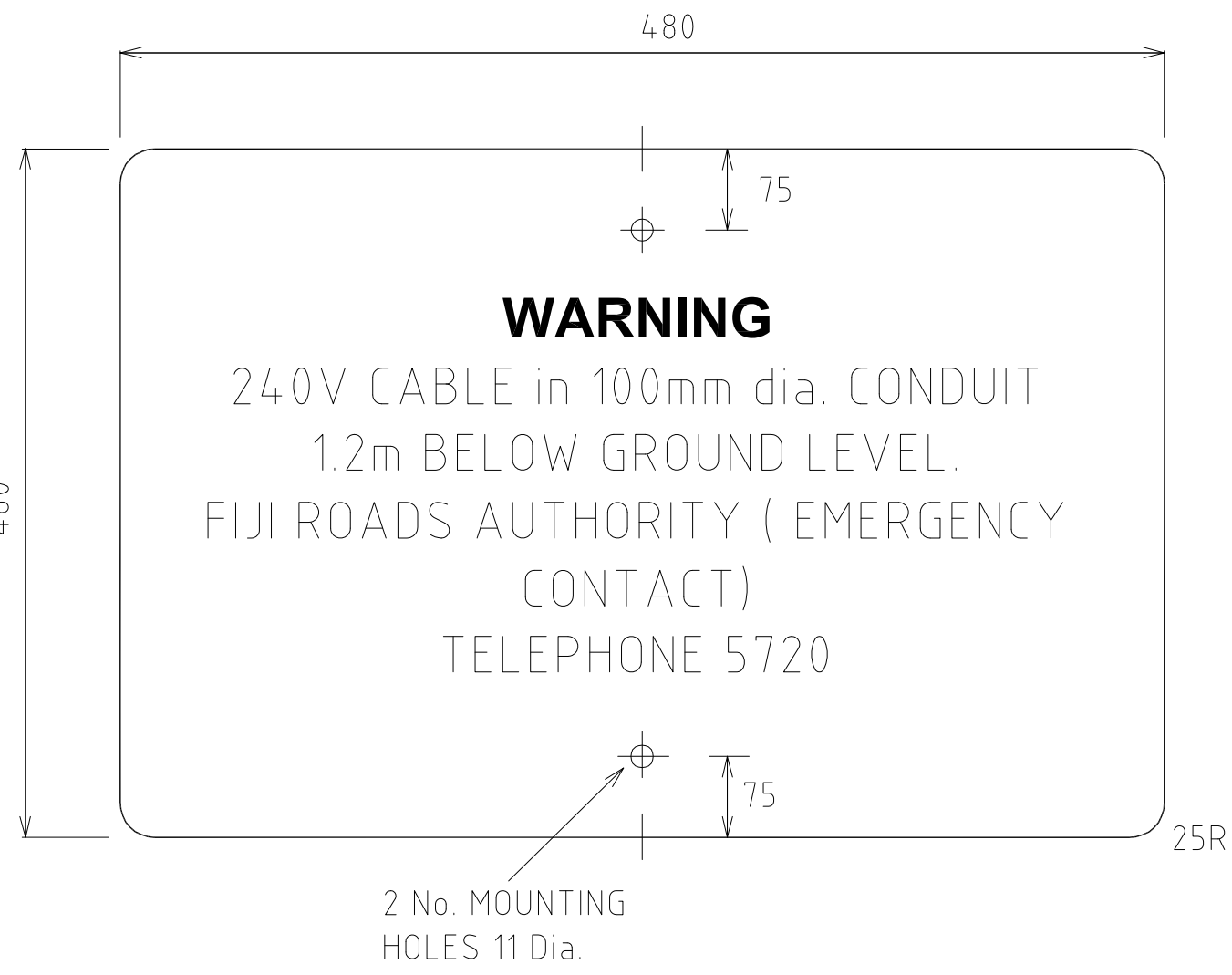

- NOTES:
1. SIGN MATERIAL TO BE ALUMINIUM SHEET 5mm Min THICKNESS.
  2. LETTERS OF 18mm Min. HEIGHT STAMPED INTO ALUMINIUM SHEET.
  3. INSTALLATION OF SIGN TO BE IN ACCORDANCE WITH ITEM 2.10 OF THE RAILWAYS OF AUSTRALIA CODE.
  4. SIGN TO BE MOUNTED USING 2 No SINGLE SIDED CLAMPS.

E				
D				
C				
B				
A				
ISSUE	APPD	DATE	AMENDMENT	BY

GENERAL NOTES

**STANDARD DRAWINGS**

TYPICAL LAYOUT  
UNDERGROUND CONDUIT WARNING SIGN

SCALE 5m  
SCALE 1:100

DATE 30 MAR 17

DESIGN BY

**Fiji Roads Authority**

DRAWN BY TT	APPROVED A KETENILAGI	DRAWING No. FRA-R 800-02	SHEET No. 01	ISSUE A
----------------	--------------------------	-----------------------------	-----------------	------------

PLOT DATE 25/02/2018

150  
100  
50  
40  
30  
20  
10

A3 ORIGINAL SIZE

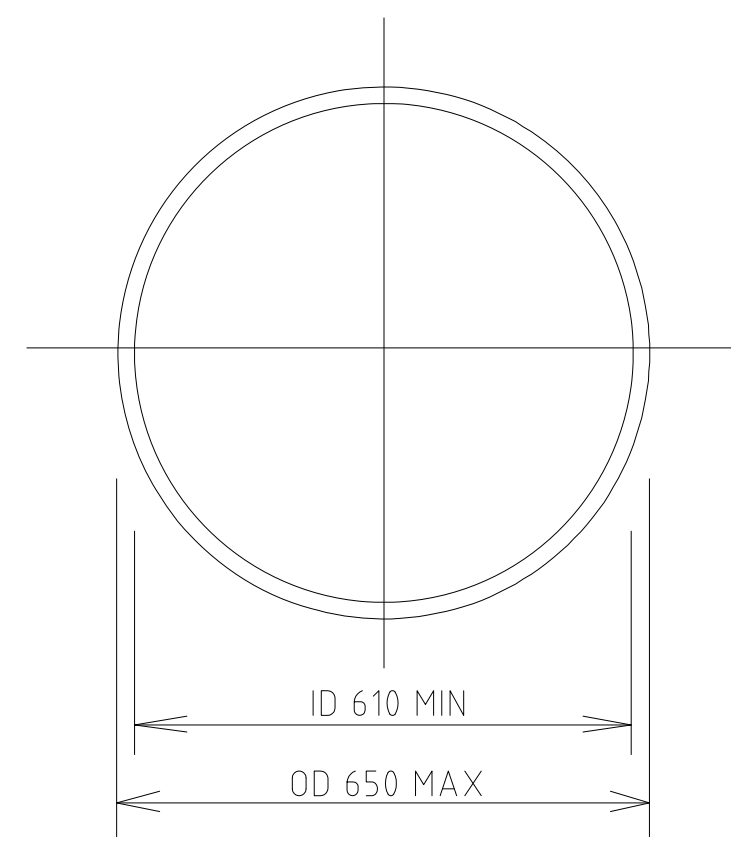
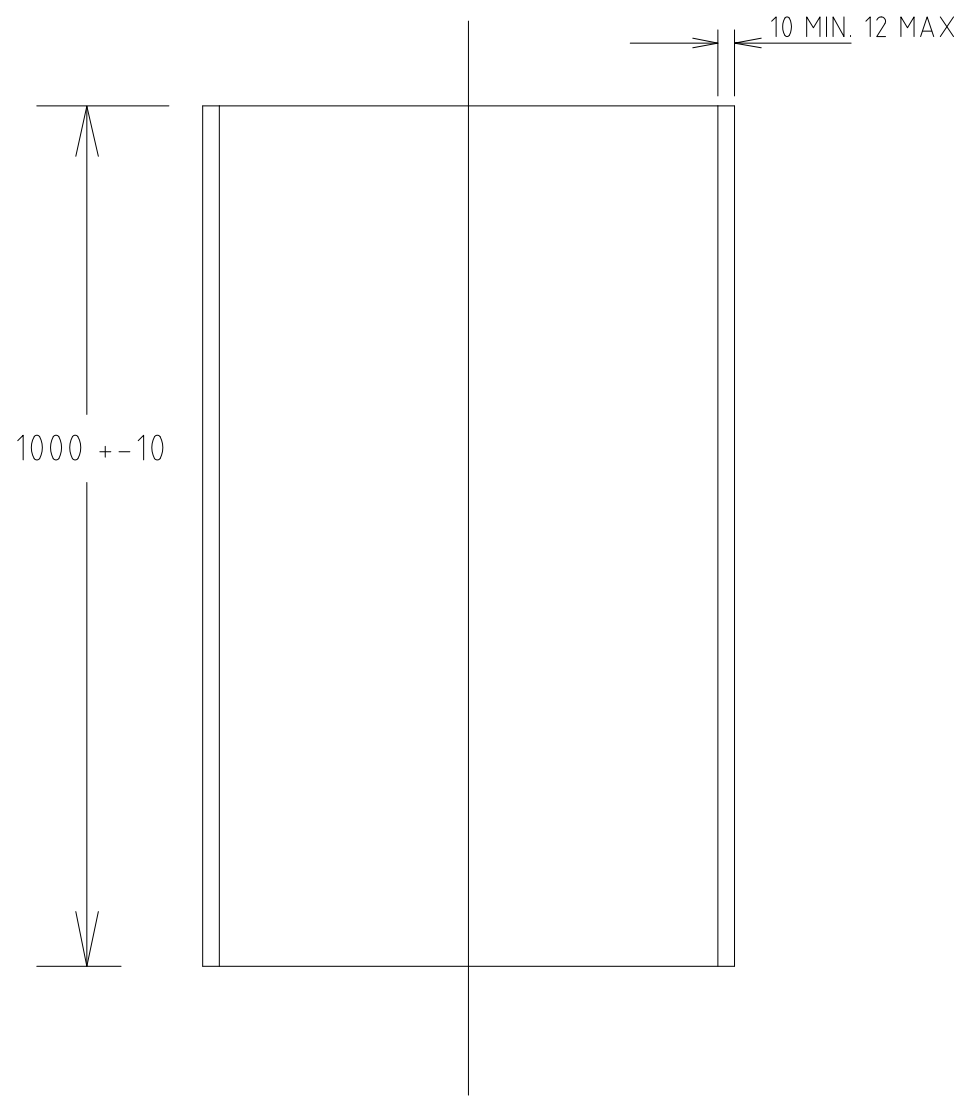

NOTES:

1. DIMENSIONS ARE IN MILLIMETERS UNLESS OTHERWISE SPECIFIED.
2. MATERIAL BLACK HIGH DENSITY POLYETHYLENE OR AS SPECIFIED.
3. ENDS TO BE SQUARE AND FREE OF BURRS.

E				
D				
C				
B				
A				
ISSUE	APPD	DATE	AMENDMENT	BY

GENERAL NOTES

STANDARD DRAWINGS

CABLE PIT FORMER  
STANDARD 600mm DIA

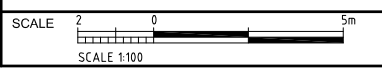

DATE 30 MAR 17

DESIGN BY

DRAWN BY TT

APPROVED A KETENILAGI

DRAWING No. FRA-R 800-03

SHEET No. 01

ISSUE A

PLOT DATE 25/02/2018

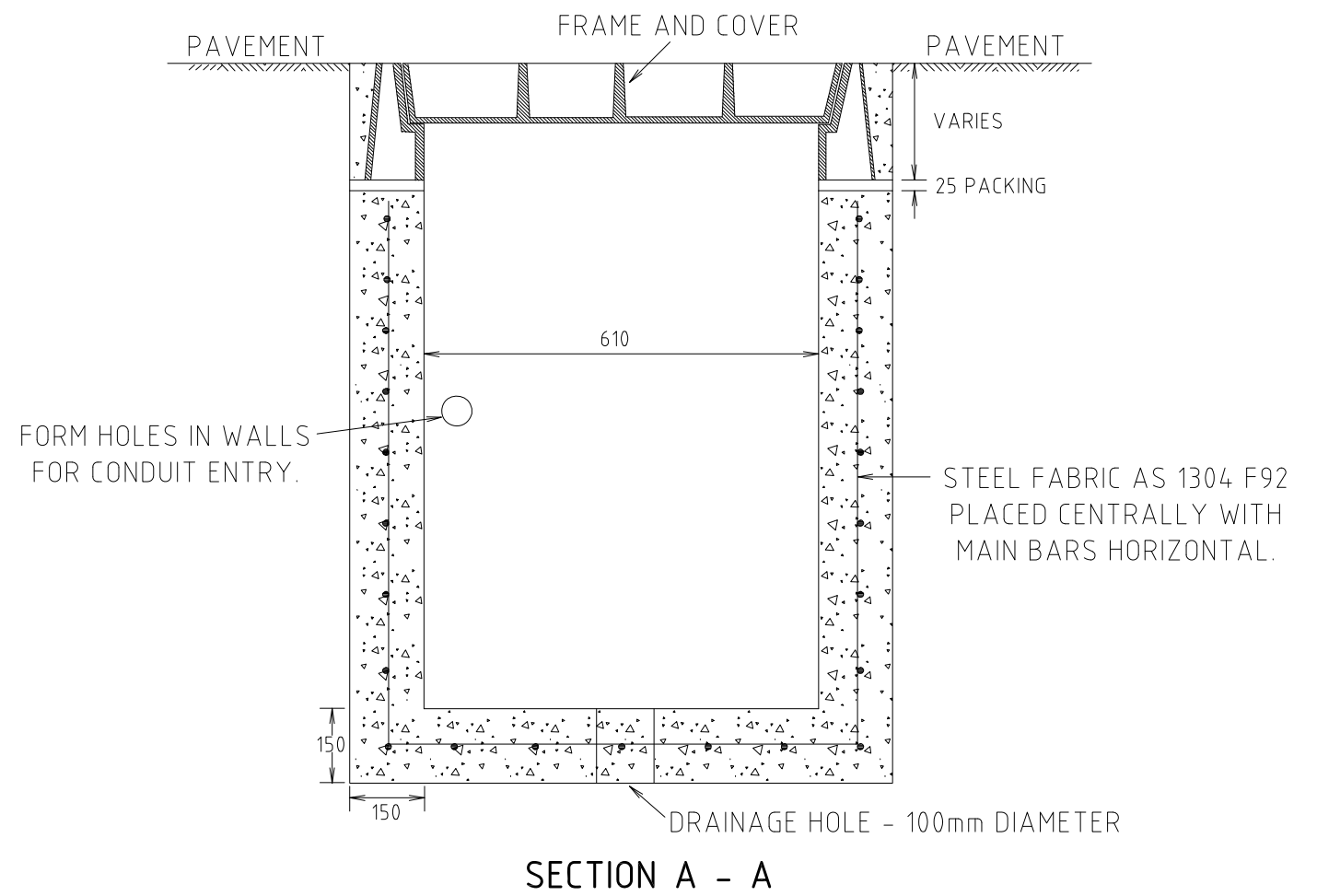
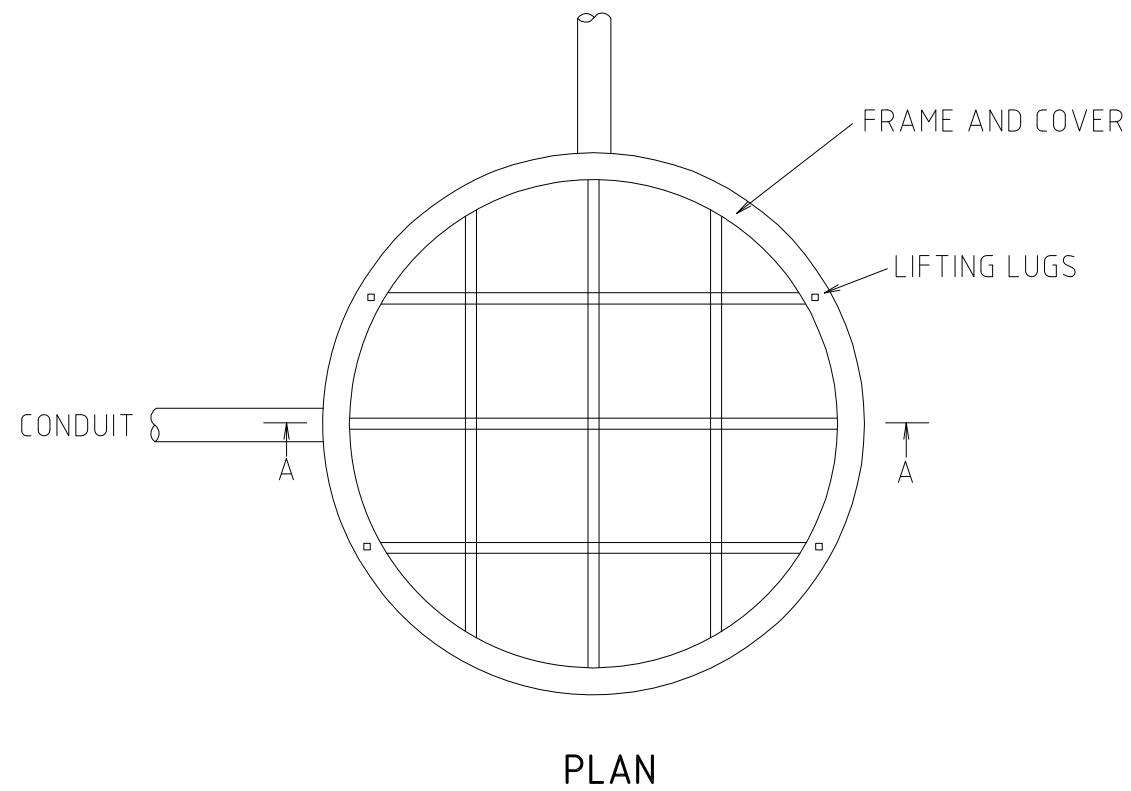

**NOTES:**

1. WALL THICKNESS AND REINFORCEMENT SHOWN SHALL APPLY TO ALL PITS UP TO 2400mm DEEP.
2. ALL REINFORCEMENT LAPS TO BE 300mm LONG.
3. PITS DEEPER THAN 1200mm AND LESS THAN 2400mm TO BE FITTED WITH STEP-IRONS. PITS DEEPER THAN 2400mm TO BE FITTED WITH LADDER.
4. STRENGTH OF CONCRETE SHALL BE 25MPa AT 28 DAYS.
5. ALL DIMENSIONS IN MILLIMETERS UNLESS OTHERWISE SHOWN.
6. HEAVY DUTY PIT LIDS TO COMPLY WITH AS 3996 - 1992 FOR CLASS D ACCESS COVERS.

A3 ORIGINAL SIZE	E				
	D				
	C				
	B				
	A				
ISSUE	APPD	DATE	AMENDMENT	BY	

GENERAL NOTES

**STANDARD DRAWINGS**

HEAVY DUTY CABLE PIT AND COVER

SCALE SCALE 1:100

DATE 30 MAR 17

DESIGN BY

**Fiji Roads Authority**

DRAWN BY TT	APPROVED A KETENILAGI	DRAWING No. FRA-R 800-04	SHEET No. 01	ISSUE A
----------------	--------------------------	-----------------------------	-----------------	------------

PLOT DATE 26/02/2018

A3 ORIGINAL SIZE

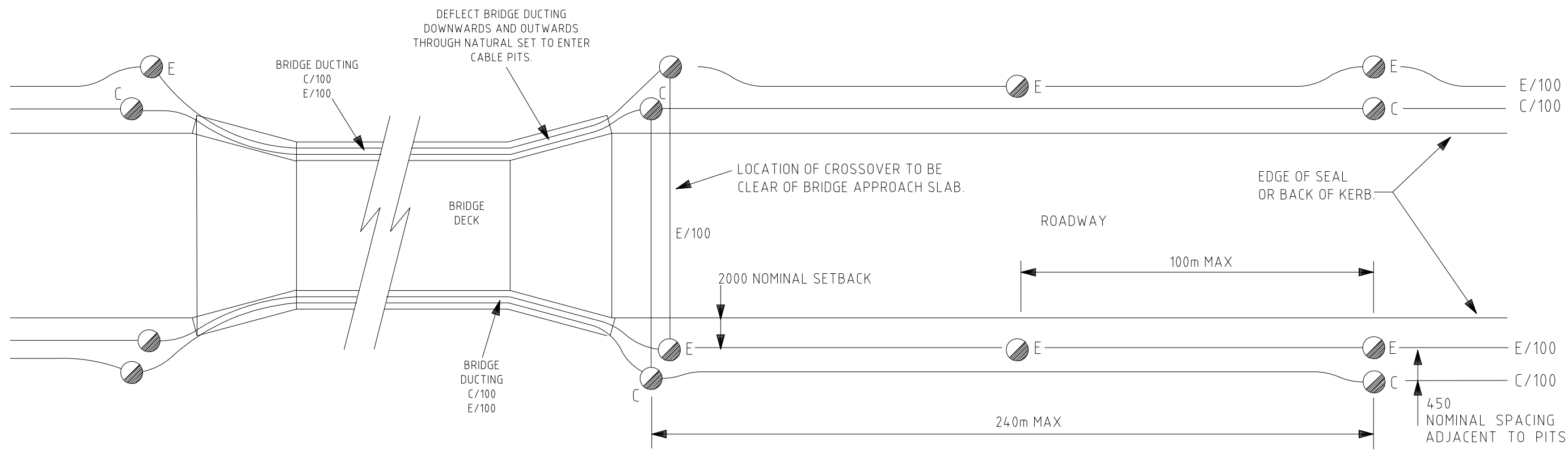

**NOTES:**

1. ALL CONDUITS SHALL BE INSTALLED IN ACCORDANCE WITH STANDARD SECTION 733.
2. MINOR CHANGES IN DIRECTION OF CONDUIT MAY BE MADE BY A NATURAL SET IN ACCORDANCE WITH 733.
3. ALL OTHER CHANGES OF DIRECTION SHALL BE VIA A CABLE PIT IN ACCORDANCE WITH 733.
4. ELBOWS SHALL NOT BE USED FOR A CHANGE IN DIRECTION.
5. ROAD CROSSING CONDUITS TO BE INCLUDED NOT MORE THAN EVERY 1000m

**LEGEND :**

- = CABLE PIT (ELECTRICAL)
- = CABLE PIT (COMMUNICATION)

CONDUIT SPECIFICATION (TO AS2053)

- E/100 = ELECTRICAL (ORANGE) HEAVY DUTY CONDUIT 100mm DIAMETER
- C/100 = COMMUNICATION (WHITE) HEAVY DUTY CONDUIT 100mm DIAMETER

E				
D				
C				
B				
A				
ISSUE	APPD	DATE	AMENDMENT	BY

GENERAL NOTES

**STANDARD DRAWINGS**

TYPICAL LAYOUT  
TRUNK CONDUIT SYSTEM FOR MAIN ROADS

SCALE SCALE 1:100

DATE 30 MAR 17

DESIGN BY

**Fiji Roads Authority**

DRAWN BY TT	APPROVED A KETENILAGI	DRAWING No. FRA-R 800-05	SHEET No. 01	ISSUE A
----------------	--------------------------	-----------------------------	-----------------	------------

PLOT DATE 28/02/2018

150

100

50

40

30

20

10

A3 ORIGINAL SIZE

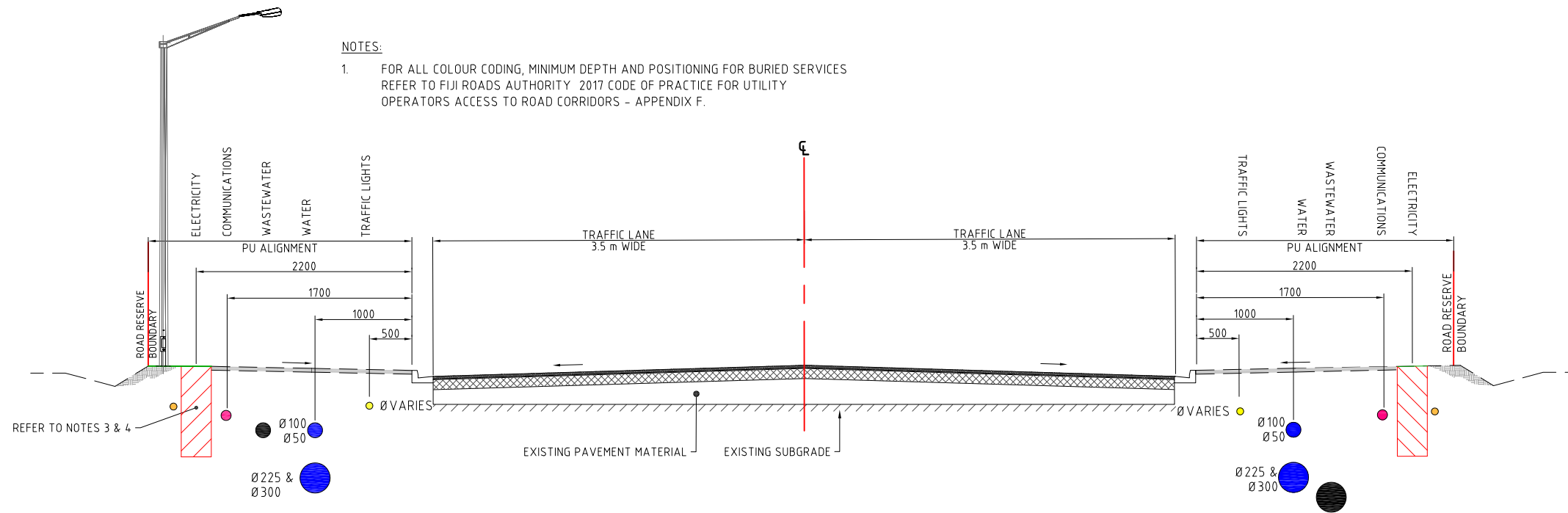

**TYPICAL CROSS SECTION - UTILITY SERVICES UNDER FOOTPATH**  
N.T.S

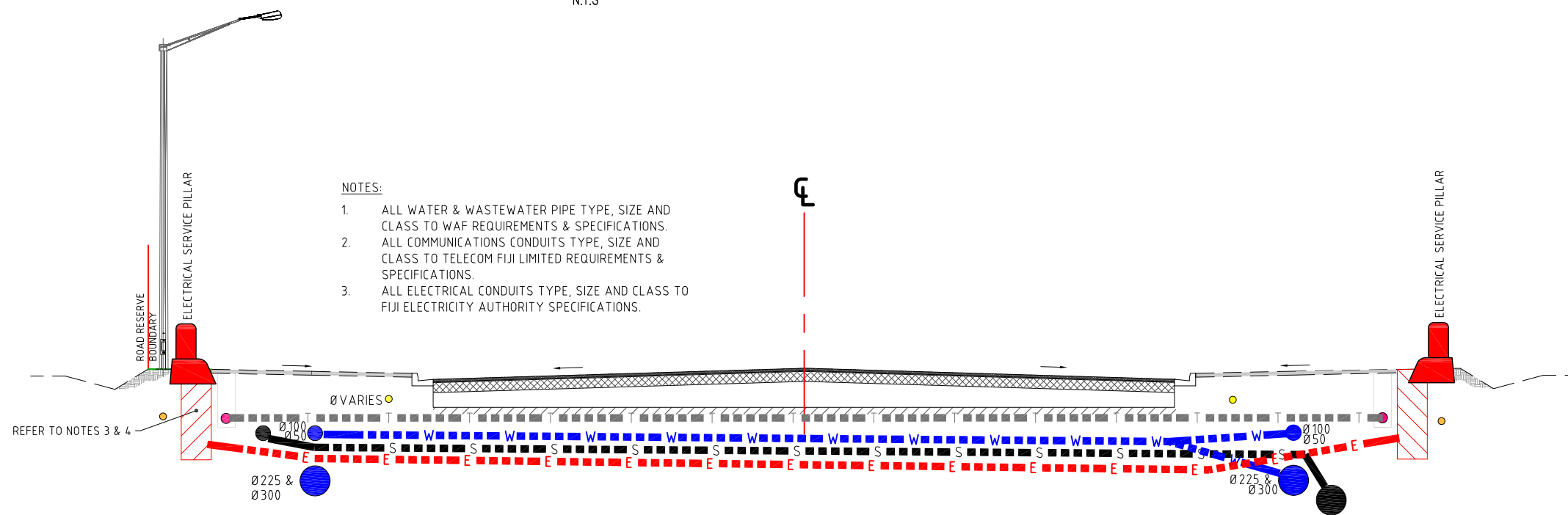

**UTILITIES LATERAL SERVICES CONDUIT SECTION**  
N.T.S

**NOTES:**  
1. FOR ALL COLOUR CODING, MINIMUM DEPTH AND POSITIONING FOR BURIED SERVICES REFER TO FIJI ROADS AUTHORITY 2017 CODE OF PRACTICE FOR UTILITY OPERATORS ACCESS TO ROAD CORRIDORS - APPENDIX F.

**NOTES:**  
1. ALL WATER & WASTEWATER PIPE TYPE, SIZE AND CLASS TO WAF REQUIREMENTS & SPECIFICATIONS.  
2. ALL COMMUNICATIONS CONDUITS TYPE, SIZE AND CLASS TO TELECOM FIJI LIMITED REQUIREMENTS & SPECIFICATIONS.  
3. ALL ELECTRICAL CONDUITS TYPE, SIZE AND CLASS TO FIJI ELECTRICITY AUTHORITY SPECIFICATIONS.

- |  |  |
|--|--|
| <p>1. ELECTRICITY CONDUITS ADOPTED ARE TYPICALLY :<br/>         Ø40 FOR STREET LIGHTING<br/>         Ø80 FOR LV, 11 kV<br/>         Ø100 FOR HV, 33 kV</p> <p>2. COMMUNICATIONS CONFIGURATIONS CONSIST OF :<br/>         DISTRIBUTION :<br/>         Ø100 CONDUITS AND PITS INSTALLED IN A COMMON TRENCH WITH ELECTRICITY LOW OR HIGH SIDE REFER NOTES 3 AND 4 AND BSD - 1015,<br/>         MAINS:<br/>         MULTIPLE Ø100 CONDUITS AND LARGE MANHOLES WITHIN TELECOMMUNICATIONS ON LOW SIDE.</p> | <p>3. IN ADDITION TO THE CARRIERS CONDUITS, PROVIDE A SERVICES COMMUNICATION CONDUIT TO ACCOMMODATE FUTURE DATALINK AND COMMUNITY INFRASTRUCTURE IN THE SPECIFIED LOCATIONS.</p> <p>4. FOR WATER PROPERTY SERVICES DETAILS, REFER TO WAF STANDARD DRAWINGS AND SPECIFICATIONS.</p> <p>5. FOR REQUIRED DEPTHS OF SERVICES, REFER TO FRA - CODE OF PRACTICE FOR UTILITY OPERATORS ACCESS TO ROAD CORRIDOR.</p> |
|--|--|

LEGEND	
TELE COMMS	■ ■ ■ ■ ■ T ■ ■ ■ ■ ■ T ■ ■ ■ ■ ■
WAF WATER LINE	■ ■ ■ ■ ■ W ■ ■ ■ ■ ■ W ■ ■ ■ ■ ■
STREET LIGHT & TRAFFIC CONTROL	■ ■ ■ ■ ■ TS ■ ■ ■ ■ ■ TS ■ ■ ■ ■ ■
ELECTRICITY	■ ■ ■ ■ ■ E ■ ■ ■ ■ ■ E ■ ■ ■ ■ ■
WAF WASTEWATER LINE	■ ■ ■ ■ ■ S ■ ■ ■ ■ ■ S ■ ■ ■ ■ ■
GAS	■ ■ ■ ■ ■ S ■ ■ ■ ■ ■ S ■ ■ ■ ■ ■

E					
D					
C					
B					
A					
ISSUE	APPD	DATE	AMENDMENT	BY	GENERAL NOTES

GENERAL NOTES

**STANDARD DRAWINGS**

TYPICAL LAYOUT  
TRUNK CONDUIT SYSTEM FOR MAIN ROADS

SCALE SCALE 1:100

DATE 30 MAR 17

DESIGN BY

**Fiji Roads Authority**

DRAWN BY	APPROVED	DRAWING No.	SHEET No.	ISSUE
TT	A KETENILAGI	FRA-R 800-06	01	A

